

COVER SHEET

ASO95002283
SEC Registration Number

DMCI HOLDINGS, INC.

(Company's Full Name)

3RD FLR. DA CON BLDG. 2281

PASONG TAMO EXT. MAKATI CITY

(Business Address: No., Street City / Town / Province)

HERBERT M. CONSUNJI
Contact Person

888-3000
Company Telephone Number

(Last Wednesday of July)

1 2 3 1
Month Day
Fiscal Year

SEC Form 17-A
FORM TYPE

0 7 3 1
Month Day
Annual Meeting

N.A.

Secondary License Type, If Applicable

C F D
Dept Requiring this Doc

Amended Articles Number / Section

Total No. of Stockholders

Total Amount of Borrowings
Domestic Foreign

To be accomplished by SEC Personnel concerned

File Number

LCU

Document ID

Cashier

STAMPS

Remarks: Please use BLACK ink for scanning purposes

SECURITIES AND EXCHANGE COMMISSION

SEC FORM 17-A, AS AMENDED

**ANNUAL REPORT PURSUANT TO SECTION 17
OF THE SECURITIES REGULATION CODE AND SECTION 141
OF THE CORPORATION CODE OF THE PHILIPPINES**

1. For the fiscal year ended December 31, 2013
2. SEC Identification Number AS095-002283 3. BIR Tax Identification No. 004-703-376
4. Exact name of issuer as specified in its charter DMCI Holdings, Inc.
5. Philippines
Province, Country or other jurisdiction of
incorporation or organization
6. (SEC Use Only)
Industry Classification Code:
7. 3rd Floor, Dacon Building, 2281 Pasong Tamo Ext., Makati City 1231
Address of principal office Postal Code
8. Tel. (632) 888-3000 Fax (632) 816-7362
Issuer's telephone number, including area code
9. Not applicable
Former name, former address, and former fiscal year, if changed since last report.
10. Securities registered pursuant to Sections 8 and 12 of the SRC, or Sec. 4 and 8 of the RSA

<u>Title of Each Class</u>	<u>No. of Shares Outstanding</u>	<u>Amount</u>
Common Shares	2,655,494,000	Php2,655,494,000.00
Preferred Shares	3,780	3,780.00
TOTAL	2,655,497,780	Php2,655,497,780.00

11. Are any or all of these securities listed on a Stock Exchange.

Yes [X] No []

If yes, state the name of such stock exchange and the classes of securities listed therein:

Philippine Stock Exchange

Class "A" Shares & Preferred Shares

12. Check whether the issuer:

(a) has filed all reports required to be filed by Section 17 of the SRC and SRC Rule 17.1 thereunder or Section 11 of the RSA and RSA Rule 11(a)-1 thereunder, and Sections 26 and 141 of The Corporation Code of the Philippines during the preceding twelve (12) months (or for such shorter period that the registrant was required to file such reports);

Yes [X] No []

(b) has been subject to such filing requirements for the past ninety (90) days.

Yes [X] No []

13. **Php 50,462,762,994.00**

The aggregate market value of the voting stock held by non-affiliates of the registrant

**APPLICABLE ONLY TO ISSUERS INVOLVED IN
INSOLVENCY/SUSPENSION OF PAYMENTS PROCEEDINGS
DURING THE PRECEDING FIVE YEARS:**

14. Not applicable

Check whether the issuer has filed all documents and reports required to be filed by Section 17 of the Code subsequent to the distribution of securities under a plan confirmed by a court or the Commission.

DOCUMENTS INCORPORATED BY REFERENCE

15. If any of the following documents are incorporated by reference, briefly describe them and identify the part of SEC Form 17-A into which the document is incorporated:

(b) Audited Financial Statements as of December 31, 2013.

PART I - BUSINESS AND GENERAL INFORMATION

Item 1. Business

(Part I, par. (a) of Annex C)

DMCI Holdings, Inc. (the “*Company*”) was incorporated on March 8, 1995 as a holding company to consolidate all construction business, construction component companies and related interests of the Consunji Family. It was listed on the Philippine Stock Exchange on December 18, 1995.

In only a few years after incorporation, the Company has expanded its business organization to include four major subsidiaries, namely: D.M. Consunji, Inc. (DMCI), DMCI Project Developers, Inc. (PDI), Atlantic Gulf and Pacific Company of Manila, Inc. (AG&P) and Semirara Mining Corporation [(SMC) (formerly Semirara Coal Corporation)].

DMCI, a wholly owned subsidiary, is engaged in general construction services– the Group’s core business. It is also engaged in various construction component businesses such as the production and trading of concrete products and electrical and foundation works. Incorporated and founded in 1954, DMCI is currently one of the leaders in the Philippine construction industry, noted for quality projects delivered on time and its pioneering application of advanced engineering methodology. In addition, DMCI, together with its affiliate PDI, is actively engaged in real estate sales and development, launching its housing component - **DMCI Homes**, in early 2002.

PDI, another wholly owned subsidiary incorporated in 1995, is engaged in construction business-generating investments primarily through its equity participation in various project and infrastructure development activities. These ventures generate not only investment income but also construction business for DMCI. Currently, PDI, hand in hand with affiliate DMCI, is actively engaged in real estate sales and development.

SCC, a 56%-owned publicly listed company established in 1980 is engaged in the exploration, mining, development and sales of coal resources on Semirara Island in Caluya, Antique. It is currently

the Philippines' largest coal-producing company with a guaranteed long-term market by virtue of its supply contract with state-run National Power Corporation (NPC).

DMCI Power Corporation (DMCI PC), a wholly-owned subsidiary of the Company, is engaged in the business of power generation which designs, constructs, invest in, and operate power plants. On January 15, 2007, the National Power Corporation (NPC) awarded to DPC the Masbate Power Generation, one of the small utilities group (SPUG) of NPC. DPC shall take over of the power supply obligation in Masbate with a 15-year Power Supply Agreement with Masbate Electric Cooperative (MASELCO). Masbate Power Generation has a total contract of 13,000 KW of Guaranteed Dependable Capacity (GDC).

DMCI Mining Corporation (DMCI MC) is another wholly owned subsidiary engaged in ore and mineral mining and exploration. It was incorporated on May 29, 2007. It has entered into joint venture with Rusina Mining Ltd., a listed company in Australia, in which the Corporation agreed to be the independent contractor to directly undertake the mining operations in the municipalities of Sta. Cruz and Candelaria in Zambales. The mining operation is an open pit extraction of nickel, chromite, and iron laterite for direct shipping.

DMCI-MPIC Water Company, Inc. (DMWCI), is a consortium with Metro Pacific Investments Corporation and Marubeni Philippines Corp. which owns 93% equity at Maynilad Water Services, Inc. (MWSI). The Company's economic interest in MWSI decreased to 25% from 41%, after Marubeni acquired 20% of economic interest in Maynilad last February 2013.

(1)(b) Any bankruptcy, receivership or similar proceeding - **None**

(1)(c) Any material reclassification, merger, consolidation, or purchase or sale of a significant amount of assets not in the ordinary course of business. – **None**

(2) Business of Issuer

(a) Description of Registrant

- i. Principal products or services and their markets. – **The Company is a publicly-listed firm with subsidiaries or affiliates engaged in the businesses of construction, real estate, coal mining, nickel mining, power generation, and water distribution. Its revenues and net income are being generated and consolidated from its subsidiaries.**
- ii. Percentage of sales or revenues and net income contributed by foreign sales – **Not Applicable**
- iii. Distribution methods of the products or services – **Not Applicable**
- iv. Status of any publicly-announced new product or service (e.g. whether in the planning stage, whether prototypes exist), the degree to which product design has progressed or whether further engineering is necessary. Indicate if completion of development of the product would require a material amount of the resources of the registrant, and the estimated amount - **None**
- v. **Competition.** – **Among the publicly listed companies, DMCI Holdings, Inc. is the only holding company which has construction for its primary investment, its construction business is primarily conducted by wholly-owned subsidiary, D.M. Consunji, Inc. (DMCI), which has, for its competitors, numerous construction contracting companies, both local and foreign, currently operating in the country. It has been an acknowledged trend that the state of construction industry depends mainly on prevailing economic conditions. Thus, the currently weak economic growth explains the continued slump in the construction industry. Given this trend, DMCI has**

been focusing on selected markets where construction demand has remained relatively strong, particularly, in housing and civil works. This is where the company believes it can compete effectively given its strong construction capabilities, equipment and manpower complement, and track record. The Company's coal mining is the largest coal producer in the country. Competition is insignificant as far as domestic coal mine is concerned. The real estate business, on the other hand, is targeted for the middle income families. As far as local sales in concerned, DMCI Homes is well-positioned to capture the end-user market with much lower price for the same market with that of its competitor. In water distribution, Maynilad covers the West concession area of Metro Manila and there is no competition with regard to water distribution in the area that it covers.

- vi. **Sources and availability of raw materials and the names of principal suppliers;** If the registrant is or is expected to be dependent upon one or a limited number of suppliers for essential raw materials, energy or other items, describe. Describe any major existing supply contracts. – **Not applicable to DMCI Holdings, Inc. For DMCI, it has its own pool of equipment and construction materials supply. For Semirara, it has an existing long term supply contract with National Power Corporation (NPC) for its power plant in Calaca, and with Toledo Power Plant.**
- vii. Disclose how dependent the business is upon a single customer or a few customers, the loss of any or more of which would have a material adverse effect on the registrant and its subsidiaries taken as a whole. Identify any customers that account for, or based upon existing orders will account for, twenty percent (20%) or more of the registrant's sales; Describe any major existing sales contracts – **Not applicable to DMCI Holdings, Inc. For SCC, it has an existing long term supply contract with National Power Corporation (NPC) which accounts for approximately 98% of its revenues. For Maynilad, it covers the West concession area of Metro Manila which accounts for nine (9) million customers. Other subsidiaries have various customers in terms of location, profile and target market.**

(viii) Transactions with and/or dependence on related parties – **Aside from inter-company transactions within the group of companies, and SCC's long term supply contract with NPC, the Company has no known transactions with and/or dependence on related parties.**

(ix) Summarize the principal terms and expiration dates of all patents, trademarks, copyrights, licenses, franchises, concessions, and royalty agreements held; Indicate the extent to which the registrant's operations depend, or are expected to depend, on the foregoing and what steps are undertaken to secure these rights – **Not applicable to DMCI Holdings, Inc. For DMCI, it is and remains a triple-A ("AAA") licensed contractor, given by the Philippine Construction Accreditation Board (PCAB), in consideration of certain minimum requirements such as: (1) financial capacity; (2) equipment capacity; (3) experience of firm; and (4) experience of technical personnel. For SMC, royalty agreements are: (1) Royalty Agreement with the Department of Energy (DOE) – 3% royalty based on FOB Sales; (2) Royalty Agreement with land claimants – P0.50/MT for untitled land and P1.00/MT for titled land.**

(x) Need for any government approval of principal products or services. If government approval is necessary and the registrant has not yet received that approval, discuss the status of the approval within the government approval process – **None at the moment.**

(xi) Effect of existing or probable governmental regulations on the business – **Not applicable to DMCI Holdings, Inc. For DMCI, it is required under Philippine laws to secure construction permits and environmental clearances from appropriate government agencies prior to actually undertaking each project. For SMC, it is required under Philippine laws to secure mining and exploration permits, as well as environmental clearances from appropriate government agencies for its continuing operations.**

(xii) Indicate the amount spent on research and development activities, and its percentage to revenues during each of the last three fiscal years – **None**

(xiii) Costs and effects of compliance with environmental laws – **Not directly applicable to DMCI Holdings, Inc., but only to its operating subsidiaries. Costs vary depending on the size and nature of a construction project for the construction and real estate businesses. Failure to comply with the terms of the ECC (environmental compliance certificate) can lead to imposition of fines and temporary cessation of operations.**

(xiv) Total Number of Employees

The total number of employees of the Company is twelve (12). The Company does not anticipate hiring additional employees for the ensuing year except when due to contingencies resulting in separation, resignation, termination of services of existing employees.

Executive	3
Senior Officers	1
Officers	4
Rank and File	<u>4</u>
Total	12

No employees are subject to either collective bargaining agreement (CBA), strike or union in both the Parent and its subsidiaries. There are no supplemental benefits or incentive arrangements between the employees and the Company.

Discuss the major risk/s involved in each of the businesses of the company and subsidiaries. Include a disclosure of the procedures being undertaken to identify, assess and manage such risks. – **Major risks for the Company and its subsidiaries are operational, regulatory and financial risks. The Corporation has commissioned SGV & Co. to assist in handling Enterprise Risk Management among DMCI Group. The Company has conducted an Enterprise Risk Awareness Session initially to the Board of Directors followed by Risk Awareness workshops among executive managers of the subsidiaries. ERM activities of the Company are in line and in accordance with latest IAS adopted as PAS and other compliance requirements from SEC and PSE.**

Item 2. Properties
(Part I, par. (b) of Annex C)

(B) Give the location and describe the condition of the principal properties (such as real estate, plant and equipment, mines, patents, etc.) that the registrant and its subsidiaries own. If the registrant does not have complete ownership of the property, for example, others also own the property or there is a mortgage or lien on the property, describe the limitations on ownership. Indicate also what properties it leases, the amount of lease payments, expiration dates and the terms of renewal options. Indicate what properties the registrant intends to acquire in the next twelve (12) months, the cost of such acquisitions, the mode of acquisition (i.e. by purchase, lease or otherwise) and the sources of financing it expects to use. - **All properties are owned by the Company and its subsidiaries unless otherwise indicated as follows:**

SEMIRARA MINING CORPORATION

(1) Property. - The mine site located in Semirara Island, Caluya, Antique, is part of the coal mining reservation under Proclamation No. 649 issued by then President Manuel L. Quezon on November 20, 1940. Certain areas in the minesite are leased with rental payments of ₱6,177,830 for 2013. The infrastructures and road network, office administration buildings, and power plants, are some of the improvements made by the Company on the leased area, as well as the following:

a. <u>Building/Offices:</u>	Units		Units
Administration Building	1	MS1 near Hospital	1
Analab Building	1	MS2 Building	1
Briquetting Building	1	MS4 Building	1
Civil Works Office & Warehouse	1	MS5 Building	1
Coal Power Plant	1	MS7 Building	1
Coal Silo	4	Oxygen/Acetylene Building	2
Core House	1	Panama Complex	1
CRO Office	1	Pitshop	1
Diesel/Bunker Power Plant	1	Product Office	1
Drilling shop	1	RMO Office	1
Genset Shed at CPP	1	Sand Blasting Plant	1
HRD Office & Library	1	Shipping Office	1
Humic Acid Plant	1	Splicing Building	1
Lime Plant	1	Tire Shop	1
Magazine Building	3	Warehouse	1
Main Workshop	1	Warehouse Auxiliary Building	1
Mayflower Motorpool	1	Washing Plant Office	1
Motorpool	1		

b. <u>Housing:</u>	Units		Units
Altar Boys Quarter	1	Lebak Housing	145
Group Staff House	2	Molave Housing (Laborer's Unit)	911
Individual Staff House	3	Pinatubo Housing	51
Kalamansig Housing	78	Staff House at Tabunan	2
Laborer's Clusters 1-7	58	Waffle Crete Building	2

Altar Boys Quarter	1	Lebak Housing	145
--------------------	---	---------------	-----

c. <u>Others:</u>	Units		Units
Classrooms for Bunlao Elem School	6	Messhall at Tabunan	1
Classrooms for Mother School	10	Messhall at waffle crete	1
Classrooms for Semirara High School	12	Mix Commercial Building	3
Classrooms for Tinogboc ElemSchool	10	Multi-purpose Gym	3
Classrooms for Villaresis Elem School	4	Multi-purpose Hall at Bunlao	1
Coast Guard Building	1	Multi-purpose Hall at Phase 1	1
Commissary Building	1	Multi-purpose Hall at Phase 4	1
Commuter terminal	1	ONB ATM Machine Building	1
Covered tennis court	1	ONB Semirara Branch	1
Divine Word School of Semirara	4	Oval at Pinaggala Area	1
DWSSI Gym	1	Pall Water Filtration Plant	1
Foodcourt	1	Pottery Building	1
Gantry at Mayflower	1	Pump house & landscaping	1
Gantry at MWS	1	Semirara Airstrip	1
Grotto	1	Semirara Library Hub	1
Guadalupe Church	1	Semirara Plaza	1
Hangar	3	Semirara Training Center (STCI)	3
HTPC Convent	1	Sitio Villaresis pier	1
Ice Plant	1	Slaughter House	1
Material Recovery Facility	1	Slipway	1
Messhall 1	1	SMC Infirmary	1
Messhall at Cluter 5	1	Smart Site Tower	1
Messhall at Cluter 7	1	Tabunan Hatchery & Laboratory	1

All properties with the net book values are active assets. These are all located in Semirara Island, Caluya, Antique (mine site). All properties are free of any liens and encumbrances except some mining equipments used as collateral for the Company's loans. The Company also invested in mining and other equipment worth ₱1.050 billion, ₱1.683 billion, and ₱2.043 billion for 2013, 2012 and 2011, respectively.

On the other hand, its power subsidiary, SCPC owns the following equipment, structures, buildings and improvements located over parcels of land subject of a lease contract for 25 years *from* the Power Sector Assets Liabilities and Management Corporation (PSALM) at Calaca, Batangas *with rental payments of ₱150,568,000 to cover the entire duration of the lease*:

1. 2x300 MW units of the Calaca Power Plant with its major components and accessories
2. Staff Housing Units
3. Guest House
4. Pier
5. Conveyor Unloading System
6. Coal Stockyard
7. Administrative Building

8. Motorpool

On July 4, 2011, SCPC exercised its option to buy several parcels of land with an aggregate area of 29.3 hectares, subject of the lease from PSALM all located within the premises of the Calaca Power Plants. SCPC assigned to its option to buy over an additional 8.2 hectare lot to the Company which option was exercised on July 4, 2011.

D.M. CONSUNJI INC.

CLASSIFICATION	PROPERTY	LOCATION
CONSTRUCTION EQUIPT & TOOLS	EARTHMOVING EQUIPMENT	VARIOUS
	COMPACTION EQUIPMENT	VARIOUS
	LIFTING EQUIPMENT	VARIOUS
	EXCAVATION EQUIPMENT	VARIOUS
	PILE DRIVING EQUIPMENT	VARIOUS
	CONCRETING EQUIPMENT	VARIOUS
	HAULING EQUIPMENT	VARIOUS
	AIR EQUIPMENT	VARIOUS
	PUMPING EQUIPMENT	VARIOUS
	POWER GENERATING EQUIPMENT	VARIOUS
	SHOP EQUIPMENT	VARIOUS
	SPECIAL SUPPORT EQUIPMENT	VARIOUS
	TOOLS & OTHER INSTRUMENTS	VARIOUS
METAL FORMWORKS	VARIOUS	
TRANSPO. EQUIPT.	SERVICE CAR	VARIOUS
	SERVICE PICK-UP	VARIOUS
	OTHER VEHICLES	VARIOUS
OFFICE FURN., FIXTURES & EQUIPT.	OFFICE FURNITURE & FIXTURES	VARIOUS
	OFFICE EQUIPMENT	VARIOUS
	COMPUTER EQUIPMENT	VARIOUS
	COMMUNICATION EQUIPMENT	VARIOUS
OTHERS	LAND	VARIOUS
	LAND IMPROVEMENTS	VARIOUS
	LEASEHOLD IMPROVEMENTS	VARIOUS
	BUILDING	VARIOUS
	BUILDING IMPROVEMENTS	VARIOUS
	PLANTS	VARIOUS

There are no construction equipment under mortgage, lien or encumbrance. DMCI plans to sell the excess construction equipment worth P30,000,000.00.

DMCI POWER CORP.

PARTICULARS	TYPE	NO. OF UNITS INSTALLED		Rated Capacity Per Unit in MW
<i>Power Plants</i>				
Mobo, Masbate	Bunker-Fired Thermal Power Plant	2	x	6.2
	Diesel Generator	2	x	2
	Diesel Generator	1	x	1
Cataingan, Masbate	Diesel Generator	3	x	1
Aroroy, Masbate	Diesel Generator	1	x	2
	Diesel Generator	1	x	1
Irawan, Palawan	Diesel Generator	5	x	1.25
	Diesel Generator	19	x	1.21
Aborlan, Palawan	Diesel Generator	3	x	1.21
El Nido, Palawan	Diesel Generator	1	x	1.21
San Jose, Occ. Mindoro	Diesel Generator	4	x	1.21

There are no power generation equipment under lease, mortgage, lien or encumbrance.

DMCI PROJECT DEVELOPERS, INC.

Classification	Property Description	Location
EQUIPMENT	Office equipment Communication equipment Furniture and fixtures Transportation equipment Machinery & other construction equipment Software Mock-up assets	Various

LAND	Residential	Bambang, Taguig Bambang 1, Taguig Bambang 2, Taguig Carmona, Cavite Bacoor, Cavite Hagonoy, Taguig Pamplona, Las Piñas Mandaluyong Taft Avenue, Manila Muntinlupa Pasay City Parañaque Quezon City Ususan, Taguig Wawa Baguio City Makati City Manila
------	-------------	--

There are no equipment or property under lease, mortgage, lien or encumbrance.

DMCI MINING CORPORATION

Machinery & Equipment				
Description	Qty	Location	Shipped/Sold to Berong	Balance 12/31/13
Excavator, Hydraulic ROBEX 210LC-7H	12	Sta Cruz, Zambales	2	10
Excavator, Hyundai Hydraulic	1	Sta Cruz, Zambales		1
Excavator, Hydraulic PC-200-8	5	Sta Cruz, Zambales	5	0
Excavator, Hyundai Wheel - Robex 200W-7	1	Sta Cruz, Zambales	1	0
Excavator, Hydraulic	1	Sta Cruz, Zambales		1
Excavator Wheel Hyundai ROBEX 200W-7	1	Sta Cruz, Zambales		1
Excavator, Hydraulic PC-200-8 with Komtrax, GPRS	1	Sta Cruz, Zambales	1	0
Excavator Hydraulic R210LC-7H	5	Sta Cruz, Zambales		5
Excavator Hydraulic PC-200LC-8	10	Sta Cruz, Zambales	6	4
Bulldozer D85EX-15R Komatsu	1	Sta Cruz, Zambales	1	0
Bulldozer D85EX-15R Komatsu	1	Sta Cruz, Zambales		1
Bulldozer D85EX-15R Komatsu	1	Sta Cruz,		1

		Zambales		
Bulldozer Komatsu D65 EX-16	1	Sta Cruz, Zambales		1
Dump Truck	7	Sta Cruz, Zambales		7
Dump Truck Hyundai HD270	4	Sta Cruz, Zambales		4
Dump Truck Hyundai HD270	6	Sta Cruz, Zambales		6
Dump Truck Hyundai HD270 15CU.M. CAP	2	Sta Cruz, Zambales		2
Dump Truck Hyundai HD270	10	Sta Cruz, Zambales		10
Dump Truck Hyundai HD270 15CU.M. CAP	15	Sta Cruz, Zambales		15
Grader Motor GD405A-2	1	Sta Cruz, Zambales	1	0
Grader Motor MG-400 Mitsubishi Engine	1	Sta Cruz, Zambales		1
Truck Water Fuso FV415J 10,000LTS (AS IS)	1	Sta Cruz, Zambales		1
Truck Water 16,000LTS Capacity	1	Sta Cruz, Zambales	1	0
Jaw Crusher (Used)	1	Sta Cruz, Zambales		1
Drilling Machine	1	Sta Cruz, Zambales		1
Tractor Crawler - Komatsu MDL D65ex-15	1	Sta Cruz, Zambales		1
Tractor Boom IsUZU Forward AS-IS, 6W,8 Tons 4WD	1	Sta Cruz, Zambales		1
Microwave Oven Brand: Milestone MDL. Start D	1	Sta Cruz, Zambales		1
Bomag BW211D-40 Single Drum Vibratory Roller	1	Sta Cruz, Zambales	1	0

There are no equipment or property under lease, mortgage, lien or encumbrance.

Item 3. Legal Proceedings

Except for the following, none of the directors, executive officers and nominees for election is subject to any pending material legal proceedings.

Consolidated Criminal Complaints of
Rodolfo V. Cruz, et al. v. Isidro A. Consunji,
Edwina C. Laperal, Cesar A. Buenaventura, et al.
IS Nos. 03-57411-I, 03-57412-I, 03-57413-I,
03-57414-I, 03-57415-I, 03-57446-I and 03-57447-I

Semirara Mining Corporation

1. **The HGL Case.** - Sometime in January 2004, the Company received a complaint filed by HGL Development Corporation (“HGL”). The facts are as follows:

On August 28, 1984, HGL entered into a Forest Land Grazing Lease Agreement (FLGLA No. 184) with the Department of Environment and Natural Resources (“DENR”) covering a 367-hectare land located at the barrios of Bobog and Pontod, Semirara, Antique. In its Order dated December 6, 2000, the DENR cancelled FLGLA No. 184 explaining that the subject area is within the coverage of Proclamation No. 649, which set apart the island of Semirara in the Province of Antique as coal mining reservations. HGL filed a letter requesting a reconsideration of the Order but the request was denied in the DENR’s letter-Order dated December 9, 2002.

The Caloocan Case:

On November 17, 2003, HGL filed a complaint against the DENR for specific performance and damages in Branch 121, Regional Trial Court of Caloocan City (RTC-Caloocan). HGL prayed that DENR should perform its obligations under FLGLA No. 184 and pay HGL for moral and exemplary damages and attorneys’ fees.

On March 2, 2004, the Company filed a Motion for Intervention because the Order canceling FLGLA No. 184 sought to be reconsidered by HGL covers property located in the island of Semirara, Antique, which was granted by RTC-Caloocan. Subsequently, the Company filed a Motion to Dismiss on the ground of lack of cause of action/jurisdiction and forum shopping. The Company’s prayer for dismissal and its subsequent Motion for Reconsideration having been both denied, the Company filed its Petition for Review with the Court of Appeals (CA) on November 28, 2005 on the premise that RTC-Caloocan has no jurisdiction over the case.

On January 16, 2007, the CA reversed RTC–Caloocan’s decision and finding grave abuse of discretion on the part of the presiding judge for failing to dismiss the case for lack of jurisdiction. The CA ruled that the DENR Order canceling the FLGLA No. 184 of HGL had long been final and executory on account of its failure to appeal said Order to the Office of the President. Eventually, HGL’s Motion for Reconsideration was denied by the CA and accordingly dismissed the case.

Due to CA’s denial of HGL’s Motion for Reconsideration, a Petition for Certiorari (SC G.R. No. 177844, 2nd Division) was filed by HGL before the Supreme Court (SC) on November 14, 2007, which was denied by the SC for failure of HGL to sufficiently show any reversible error in the assailed CA decision and further denies HGL’s motion for leave and first and second motions of time to file a reply to the Company’s comments on the petition. HGL’s Motion for Reconsideration was denied with finality by the SC on July 2, 2008.

Meanwhile, in a case docketed as SC G.R. No. 180401, 1st Division (*DENR vs. HGL*), DENR’s Petition for Certiorari was denied by the SC on February 4, 2008. DENR then filed its Motion for Reconsideration on March 25, 2009, which later denied by the SC with finality.

Citing as basis the dismissal of the Culasi Case (SMC vs. HGL) on the ground of forum shopping, SMC filed a Motion to Dismiss with RTC-Caloocan (Civil Case No. C-20675). However, RTC-Caloocan denied the motion on December 24, 2008 and cited the SC decision on G.R. No. 180401 (*DENR vs. HGL*) to sustain its decision to retain jurisdiction over the case. With the denial of its MR on June 24, 2009 (CA-G.R. SP No. 110460). On October 3, 2013 the CA dismissed the Corporation’s petition to which a Motion for Reconsideration was filed on November 22, 2013. The case is pending to date.

The Culasi Case:

HGL also filed a separate case against the Company on November 17, 2003 in Branch 13 of the Regional Trial Court of Culasi, Antique (RTC-Culasi) for the recovery of their alleged possession of a 367-hectare land located at the barrios of Bobog and Pontod, Semirara, Antique. HGL prayed for (i) the issuance of a preliminary mandatory injunction in order to secure immediate possession of the property pending litigation, and (ii) actual, moral and exemplary damages and attorney's fees in the total amount of P10 million. The Company received the summons on January 15, 2004.

On February 6, 2004, the Company filed its Answer and prayed for the outright dismissal of the case for being baseless and unfounded as the Order canceling FLGLA No. 184 had long been final and executory and can no longer be disturbed. The Company claims exemplary and moral damages and attorneys' fees.

On September 16, 2004, the RTC-Culasi granted HGL's prayer for preliminary mandatory injunction, which order was affirmed by the CA-Cebu. The Company elevated the case to the SC by way of Certiorari with prayer for Temporary Restraining Order (TRO) and/or Injunction to be issued against HGL, the CA-Cebu and RTC-Culasi. The SC initially granted the TRO on March 2, 2005, but on December 06, 2006, the SC denied the Company's Petition for Certiorari and lifted the TRO. On January 18, 2007, the Company filed a Motion for Reconsideration and later on January 25, 2007 due to the ruling by the CA in the Caloocan Case filed a Supplemental Motion for Reconsideration. On February 14, 2007, the SC denied with finality the Company's Motion for Reconsideration and its supplement to the aforesaid motion for lack of merit.

Meanwhile, on July 16, 2007, the RTC-Culasi dismissed the main case, as the two (2) cases filed by HGL was a deliberate violation of the rule on forum shopping. RTC-Culasi further stated in its decision that in both cases, HGL's cause of action rests on the validity of its FLGLA No. 184. HGL filed its Motion for Reconsideration, but on November 20, 2007, RTC-Culasi ruled against HGL. No appeal was taken by HGL.

Thereafter, on February 5, 2008, HGL filed before the SC a Petition for Indirect Contempt docketed as "*HGL Development Corporation, represented by its President, Henry G. Lim, Petitioner vs. Hon. Rafael L. Penuela, in his capacity as Presiding Judge of RTC-Culasi, Antique, Branch 13, and Semirara Coal Corporation (now Semirara Mining Corporation, Respondents,*" SC G.R. No. 181353. HGL alleged, among others, that the dismissal of the Culasi case constitutes indirect contempt as HGL was not able to implement the SC's decision dated December 6, 2006 (affirming the earlier order of RTC-Culasi granting HGL's prayer for preliminary mandatory injunction) and resolution dated February 14, 2007, as RTC-Culasi dismissed the main case or the Culasi case on the ground of forum shopping. The Company filed its Comments/Opposition to the Petition. Subsequently, the SC required the parties to submit their respective Memoranda. The case is pending to date.

2. **Tax Refund/Credit Case.** - The Company filed several cases against the Commissioner of Internal Revenue (CIR) before the Court of Tax Appeals (CTA) for tax credit/refund due to erroneously withheld and remitted VAT on coal sales by National Power Company (NPC) to the Bureau of Internal Revenue in the total amount of ₱190,500,981.23.

- 2.1. *CTA Case No. 7717.* – On October 13, 2009, the CTA rendered a Decision granting the Company's petition in the amount of ₱11,847,055.07 for the month of December 2005. The CIR moved for reconsideration. After the Company filed its comment on November 21, 2009, the CTA on August 10, 2010 issued a Writ of Execution on its decision dated October 15, 2009. The Writ of Execution was served to BIR on August 13, 2010. Notwithstanding this, the Company's tax credit certificate remained pending with the BIR.

- 2.2. *Commissioner of Internal Revenue vs. Semirara Mining Corporation, SC G.R. No. 202534 (CTA EB No. 752)*. – On January 4, 2011, the CTA granted the Company's petition in the amount of ₱15,292,054.91 for the month of January 2007. CIR's Motion for Reconsideration was denied on March 18, 2011. CIR appealed the case to CTA En Banc (CTA EB No. 752) but the CTA En Banc dismissed the CIR's petition for lack of merit. The CIR again moved to reconsider the En Banc decision, but was denied on June 28, 2012. Thereafter, the CIR filed a petition for review on certiorari with the Supreme Court, to which the Company filed a comment. The petition remains pending to date.
- 2.3. *Commissioner of Internal Revenue vs. Semirara Mining Corporation, SC G.R. No. 202922 (CTA EB No. 772)*. – On February 10, 2011, the CTA granted the Company's petitions in the amount of ₱86,108,626.10 for the period covering January 1, 2006 to June 30, 2006. On February 22, 2011, as CIR's Motion for Reconsideration was denied, it elevated the case to the CTA *En Banc* (CTA EB No. 772), but was by the CTA *En Banc* on June 22, 2012. The CIR filed a Motion for Reconsideration but was again denied by CTA on September 17, 2012. The CIR elevated the case to the Supreme Court (SC) via a Petition for Review on November 5, 2012, but was denied in a minute resolution dated January 30, 2013. On October 10, 2013 an Entry of Judgment was issued. The Corporation filed its Motion for Issuance of a Writ of Execution with the CTA which was granted on January 21, 2014.
- 2.4. *Commissioner of Internal Revenue vs. Semirara Mining Corporation, SC G.R. No. 202922 (CTA EB No. 793)*. - On March 28, 2011, the CTA granted SMC's petition in the amount of ₱77,253,245.39 for the periods covering July 1, 2006 to December 31, 2006. The CIR's Motion for Reconsideration was denied on June 3, 2011. The CIR elevated the case to the CTA *En Banc* (CTA EB 793), but the CTA dismissed the petition on April 23, 2012 for lack of merit. As the CIR's Motion for Reconsideration was likewise denied on May 29, 2012, it filed a petition with the Supreme Court. The Corporation filed a Comment on December 28, 2012 to the CIR's Petition. On October 25, 2013, the SC issued a notice granting the CIR's Motion to Admit Reply and a copy of the Reply. The case remains pending to date.
3. ***SMC vs. Municipality of Calaca, RTC- Makati City, Branch 137, Civil Case No. 07-180*** (Business Tax Case). - On February 26, 2007, the Company filed a complaint () to seek the reversal and cancellation of the tax assessment by the Municipality of Calaca for unpaid business tax for the CY 2003, 2004 and 2005 in the amount of ₱66,685,189.00. The basis of the claim is that since coal is being delivered to the port of Calaca and that the Company is doing business there as shown by the existence of an office; therefore, the situs of taxation is in Calaca. The Company maintains that it is not maintaining an office in the Municipality of Calaca, despite delivery to NPC-Calaca, hence the proper situs of taxation is not in Calaca but in its principal office. The Corporation presented all its witnesses and submitted its formal offer of documentary exhibits. Subsequent hearings will be for presentation of defendant's evidence.
4. ***Municipality of Caluya, Antique vs. SMC, RTC-Culasi, Branch 13, Civil Case No. C-051*** (Real Property Tax Case). - On February 19, 2008, the Municipality of Caluya Antique filed a case against the Company for enforcement of the compromise agreement submitted to the RTC on November 17, 2003 involving the balance of ₱82,979,702.24 in real property taxes for lots located in Semirara Island. The Company maintains that the Motion for Execution has no legal basis and premature due to a clause in the compromise agreement requiring the parties first determines the correctness of the tax assessments which shall be subject to the verification of the parties. The parties submitted on October 11, 2012 a Compromise Agreement dated July 2, 2012 for approval of the Court. To date the Court has yet to issue an order approving the Compromise Agreement.
5. ***Power & Synergy, Inc. vs. SMC, et. al, RTC-QC, Branch 97, Civil Case No. Q-10-66936*** (Specific Performance Case). – The complaint alleges fraudulent acts against the Company and its directors and officers, and prayed that defendants jointly and severally perform and comply

with the terms and conditions under the Consultancy Agreement. PSI is in effect claiming a success fee of ₱1.3 billion (due to increase in coal volume sold to NPC) by the end of 2010. On June 2, 2010, moved for the dismissal for lack of jurisdiction over the case, improper venue in so far as other individual defendants are concerned, and the complaint states no cause of action. The RTC required PSE to pay the correct docket fees, but PSI moved for reconsideration. To date, the Court is yet to rule on both motions of the Corporation and PSI.

6. ***Gabinete, et. al. vs. SMC, et. al, Civil Case No. 210-C, MCTC-Pandan, Antique*** (Forcible Entry Case). – The complaint hinges from the alleged entry of the Company to a portion of plaintiffs' properties located in Barangay Alegria, Caluya, Antique. Plaintiffs' prayed to the Court to order defendants to vacate the properties and pay damages and attorney fees. On March 10, 2014 the Corporation submitted its affidavits and position paper..
7. ***Gabinete, et. al. vs. SMC, et. al., Civil Case No. C-260, RTC-Culasi, Antique, Branch 13*** (Annulment of Deeds of Sale Case). – The complaint seeks the annulment of deeds of sale plaintiff executed with the defendant George G. San Pedro covering parcels of land located in Brgy. Alegria, Caluya, Antique due to alleged unsound mind of the plaintiff at the time of execution. After defendants filed their answer, the RTC scheduled the pre-trial conference on February 10, 2014.
8. ***Bornea, Jr., vs. SMC, et. al., NLRC-Cagayan de Oro City, NLRC Case No. RAB-IX-11-00663-11*** (Illegal Dismissal Case). - This is an illegal dismissal case filed by Engr. Bornea docketed as with the Arbitration Branch of Davao seeking for his reinstatement as the Foreman Supervisor of the Company's mining facility in Caluya, Antique. Bornea alleged that there was no justifiable ground to dismiss and that due process was not observed. On April 24, 2012, the Labor Arbiter resolved to dismiss the complaint for lack of merit. Bornea appealed the case, but the NLRC-Cagayan de Oro City likewise dismissed the appeal for lack of merit in its Decision dated December 28, 2012. On February 19, 2013, Bornea moved to reconsider the NLRC decision, but the NLRC in its Resolution dated March 27, 2013 dismissed the motion for lack of merit. Despite this, Bornea filed with the CA a Petition for Certiorari under Rule 65. The same remains pending to date.
9. ***Semirara Mining Corporation vs. Bureau of Internal Revenue, et. al., Civil Case No. 13-1171, RTC-Makati, Branch 146*** (Declaratory Relief with Injunction against BIR, etc.). – This is a case filed by the Corporation against the BIR, Bureau of Customs & Department of Finance under Civil Case No. 13-1171, RTC Makati Br. 146. On May 21, 2013 SMC was granted a Certificate of Qualification for Tax Exemption under PD 972 by the DOE for its 36,000,000 liters of diesoline. SMC made 1st partial shipment of 6,176,367 liters. BIR assessed VAT and excise tax on said shipment in the amount of P25 M which was paid under protest. As a result SMC filed a petition for Declaratory Relief with the RTC on October 3, 2013 seeking to enjoin BIR, BOC from implementing BIR RR No. 2-2012 by imposing advance payment of VAT on SMC importation of diesel fuel for its own use and consumption. BIR rationalizes its issuance of RR No. 2-2012 for the purpose of curtailing smuggling. While under said regulations payment of VAT is subject to right of refund by SMC (effectively 0% rated) being exempted from VAT under its COC and PD 972, SMC contested the application of said regulation as it effectively diminishes its exemption granted by law and impairs the rights under its COC pursuant to the non-impairment clause of the Constitution. On October 30, 2013, SMC secured a 20-day TRO and on November 21, 2013 the court issued a preliminary injunction against the BIR, BOC and DOF in so far as the implementation of said regulation specifically against the Corporation. To date the case remains pending.
10. ***Fajardo vs. Semirara Mining Corp., et. al., Civil Case No. C-271, RTC-Culasi, Antique, Branch 13*** (Environmental Case (Writ of Kalikasan)). – Was filed pursuant to Supreme Court A.M. 09-6-8-SC on Rules of Procedures for Environmental Cases (Rules). Complainant prayed for Temporary Environmental Protection Order (TEPO) for 72 hours from receipt of the complaint for

the alleged irresponsible coal mining, serious destruction of the island, pollution of marine and coral reefs, damage to marine life, among others. Defendants filed their respective answer, but no TEPO has been issued by the RTC to date.

Except for the foregoing cases, the Company or its subsidiaries is not a party to any pending material legal proceedings. It is not involved in any pending legal proceedings with respect to any of its properties. Apart from the foregoing, therefore, it is not involved in any claims or lawsuits involving damages, which may materially affect it or its subsidiaries.

Item 4. Submission of Matters to a Vote of Security Holders

There were no matters submitted to vote of the security holders during the fourth quarter of the fiscal year covered by this report.

PART II – SECURITIES OF THE REGISTRANT

Item 5. Market for Issuer's Common Equity and Related Stockholder Matters

(A) Market Price of and Dividends on Registrant's Common Equity and Related Stockholder Matters

(1) Market Information

(a) Identify the principal market or markets where the registrant's common equity is traded. If there is no public trading market, so state - ***Both common and preferred shares of DMCI Holdings, Inc. are traded on the Philippine Stock Exchange.***

(i) If the principal market for the registrant's common equity is a Stock Exchange in the Philippines or a foreign Exchange, state the name of that Exchange and give the high and low sales prices for each quarter within the last two fiscal years and any subsequent interim period for which financial statements are required by SRC Rule 68. – ***See table below***

Common Share Prices		High	Low
2012	First Quarter	54.50	53.10
	Second Quarter	57.00	56.85
	Third Quarter	58.15	57.95
	Fourth Quarter	54.80	53.85
2013	First Quarter	55.80	53.80
	Second Quarter	51.60	51.00
	Third Quarter	47.20	45.80
	Fourth Quarter	56.70	55.20
2014	First Quarter	70.20	70.00
Preferred Share Prices		High	Low

2012	First Quarter	0	0
	Second Quarter	0	0
	Third Quarter	0	0
	Fourth Quarter	0	0
2013	First Quarter	0	0
	Second Quarter	0	0
	Third Quarter	0	0
	Fourth Quarter	0	0
2014	First Quarter	0	0

(b) If the information called for by paragraph (A) of this Part is being presented in a registration statement filed pursuant to Section 12 or in an annual report filed pursuant to Section 17 or in an information statement filed pursuant to Section 17.1(b) or in a proxy statement filed pursuant to Section 20 of the Code, respectively, the document shall also include price information as of the latest practicable trading date, and, in the case of securities to be issued in connection with an acquisition, business combination or other reorganization, as of the trading date immediately prior to the public announcement of such transaction. – **Price information as of the latest practicable trading date: As of April 24, 2013: HIGH 70.00 LOW 69.35, CLOSE 69.40, VOLUME 1,399,090.**

(c) If the information called for by paragraph (A) of this Part is being presented in a registration statement relating to a class of common equity for which at the time of filing there is no established public trading look at the schools in a busy to change in foreign aid out that some station the admin tool is acting as an informal place and the sound and the Papin is the fourth Reinoso officers home the same site of the animal and because the schools and they are not the end of the idea that an option of placing Arby Siu stir up to a new state and market in the Philippines, indicate the amounts of common equity – **Not applicable**

(2) Holders

(a) Set forth the approximate number of holders of each class of common equity of the registrant as of the latest practicable date but in no event more than ninety (90) days prior to filing the registration statement. Include the names of the top twenty (20) shareholders of each class and the number of shares held and the percentage of total shares outstanding held by each. –

Number of Shareholders: As of December 31, 2013 the Company had a total of 724 shareholders of which 708 were holders of common shares 16 were holders of preferred shares.

Common Shares: 2,655,494,000 - Of the total outstanding common shares, 445,592,583 common shares representing 16.7800% of the outstanding common shares are owned by foreign shareholders.

Title of Class	Name	Citizenship	Number of Shares Held	Percent of Class
Common	DACON Corporation	Filipino	1,215,393,901	45.769032%
Common	Philippine Central Depository, Inc. (PCD)	Filipino	465,397,483	17.525834%
Common	DFC Holdings, Inc.	Filipino	461,999,838	17.397887%
Common	Philippine Central Depository, Inc. (PCD)	Foreigner	443,,210,923	16.690338%

Top 20 Common Shareholders: The list of the Top 20 common shareholders as of December 31, 2012 as contained in Exhibit (2) is herein incorporated by reference.

(3) Dividends

(a) Discuss any cash dividends declared on each class of its common equity by the registrant for the two most recent fiscal years and any subsequent interim period for which financial statements are required to be presented by SRC Rule 68. – **See below.**

1. On April 7, 1999, the Company paid the semi-annual dividend of 2.5 % for last semester of the second year to the holders of the preferred shares.
2. On October 7, 1999, the Company paid the semi-annual dividend of 3.6 % for the first semester of the third year to the holders of the preferred shares.
3. On April 7, 2000, the Company paid the semi-annual dividend of 3.6% for last semester of the third year to the holders of the preferred shares.
4. On October 7, 2000, the Company paid the semi-annual dividend of 3.6% for the first semester of the fourth year to the holders of the preferred shares.
5. On July 20, 2006, the Company paid cash dividends at the amount of PhP 0.10 per outstanding common share to the shareholders of record of June 30, 2006.
6. On May 28, 2007, the Company paid cash dividends at the amount of Php 0.10 per outstanding common share to the shareholders of record of April 30, 2007
7. On May 30, 2008, the Company paid cash dividends at the amount of Pho 0.10 per outstanding common share to the shareholders of record of May 12, 2008.
8. On June 30, 2009, the Company paid cash dividends at the amount of Php 0.20 per outstanding common share to the shareholders of record of June 5, 2009.
9. On July 15, 2010, the Company paid cash dividends at the amount of Php 0.50 per outstanding common share to the shareholders of record of June 22, 2010.
10. On July 7, 2011, the Company paid cash dividends at the amount of Php 1.00 per outstanding common share to the shareholders of record of June 15, 2011.
11. On May 15, 2012, the Company paid cash dividends at the amount of Php 1.20 per outstanding common share to the shareholders of record of June 15, 2012.
12. On April 11, 2013, the Company declared cash dividends of Php 1.20 per common share and special cash dividends of Php 1.00 per common share to the shareholders of record of April 26, 2013.
13. On November 14, 2013, the Company declared a special cash dividends of P1.20 per common share to the shareholders of record of November 29, 2013.

(b) Describe any restrictions that limit the ability to pay dividends on common equity or that are likely to do so in the future. – **There are no contractual or other restrictions on the Company's ability to pay dividends. However, the ability of the Company to pay dividends will depend upon the amount of distributions, if any, received from the Company's operating subsidiaries and joint venture investments and the availability of unrestricted retained earnings. The Company's operating subsidiaries however are restricted on the declaration and payment of dividends, as limited by negative covenants entered into by the operating subsidiaries with outside parties.**

(4) Recent Sales of Unregistered Securities - NONE

PART III- FINANCIAL INFORMATION

A. MANAGEMENT'S DISCUSSION AND ANALYSIS OF PLAN OF OPERATION.

Full Year 2013 vs. 2012

I. RESULTS OF OPERATIONS

DMCI Holdings, Inc. (the "Company") reported a consolidated net profit of P18.9 billion (inclusive of P8.4 billion one-time gain on sale) for the year 2013, which is 95% higher than in 2012. Core net income, which was boosted by the strong profit growth of the power segment, grew by 9% to P10.6 billion in 2013 from P9.7 billion in 2012. This growth is a result of the successful synergy between the coal and power business coupled with the increased generation output of the Calaca power units. Also, the real estate segment continues to deliver double-digit growth in net income contributions due to high volume of sales and completion of several projects during the course of the year. Meanwhile, even with a slight decrease in its reported revenues, the construction segment sustained its net income contribution of P1.28 billion due to improvement of margins. On the other hand, despite the growth in water operations by 7.2% this year, the Company is reporting a lower share in net earnings from the water business as a result of the reduced effective interest in Maynilad, from 41% in 2012 to 25% in 2013.

In spite of the weak global commodity prices, which adversely affected the nickel and coal mining segments, the Company posted a record P56.0 billion in consolidated revenues in 2013, which is an 8% increase from P51.7 billion in 2012. The increase in revenue is mostly due to higher power generation sales and a surge in recognized revenues from the real estate segment.

Below is a table on the net income contributions of the Company's businesses for 2013 and 2012:

NET INCOME AFTER NON-CONTROLLING INTERESTS

<i>(in Php Millions)</i>	Audited		Variance	
	2013	2012 (as restated*)	Amount	%
COAL MINING	P1,022	P1,740	(P718)	-41%
NICKEL MINING	169	341	(172)	-50%
CONSTRUCTION	1,275	1,275	-	0%
REAL ESTATE	2,655	2,105	550	26%
POWER	3,478	1,901	1,577	83%
WATER	1,915	2,340	(425)	-18%
PARENT COMPANY	65	34	31	91%
CORE NET INCOME	10,579	9,736	843	9%
ONE-TIME GAIN ON SALE (<i>Parent</i>)	8,358	-	8,358	-
TOTAL	P18,937	P9,736	P9,201	95%

*As a result of adopting new accounting standards

WATER

The Company's investment in the water sector is recognized mainly through its equity investment in the partnership with Metro Pacific Investments Corp. (MPIC) with the actual operations under Maynilad Water Services, Inc. (Maynilad). Maynilad handles the water distribution and sewer services for the western side of Metro Manila. On February 13, 2013, MCNK JV Corporation, a subsidiary of Marubeni Corporation, acquired 20% effective ownership in Maynilad. The transaction reduced the Company's

effective interest in Maynilad from 41% to 25%. The entry of MCNK in the consortium is expected to help provide Maynilad with access to additional sources of funding and innovative technology.

Operating efficiencies continue to improve as Maynilad reported higher income from operations of P9.7 billion in 2013, up 7.2% from P9.1 billion in 2012. Billed volume was up 3.6%, despite an effective 4.4% reduction in water supply. Average non-revenue water for the year continued to stay below the 40% barrier, improving to 38.71% from 43.47% last year.

Continued expansion into the southern areas of Muntinlupa, Las Piñas and Cavite brought connections up to a total of 1,129,497 billed services, a 5.2% growth from the end of the same period last year. The combined effect of the increase in billed volume and an effective year-on-year tariff increase of 3%, mainly inflation driven, resulted to a growth in water service revenue by 7.8% from P12.5 billion in 2012 to P13.5 billion in 2013. Total revenues from operations, including other fees and services such as installation fees, amounted to P16.8 billion, a 6.0% increase from P15.8 billion last year.

Total non-cash operating expenses decreased by 10.0% to P1.9 billion from P2.1 billion last year mainly as a result of the shift to the units-of-production method of amortization beginning 2013. This method more closely aligns the consumption of economic benefit of the concession assets with the growth in billed volume. Meanwhile, total cash operating expenses increased by 10.9% to P5.1 billion versus P4.6 billion last year primarily driven by increases in personnel cost and professional fees.

As a result, reported net income grew at a rate of 7.2%, from P6.4 billion in 2012 to P6.9 billion in 2013. After adjustments at the consortium company level, the Company's equity in net earnings reported a 19% decline from P2.3 billion last year to P1.8 billion this year due to a lower effective interest as mentioned.

In 2013, Maynilad submitted its business plan for the determination of its standard rates for the period 2013 to 2017 to the Metropolitan Waterworks and Sewage System ("MWSS"), its regulator. On September 12, 2013, MWSS denied Maynilad's application for an upward adjustment and instead proposed a negative adjustment of 4.82% (or ₱1.46 per cubic meter) in what Maynilad views as a violation of its concession agreement. Maynilad did not accept the tariff proposal of MWSS and on October 4, 2013 filed a notice of dispute with the Secretariat of the International Chamber of Commerce (ICC) International Court of Arbitration for resolution. The arbitration panel will be chaired by Prof Bernard Hanotiau, a respected member of the Brussels and Paris bars. Hearings are expected to commence once the rest of the panel is formed.

On March 15, 2013, Maynilad acquired a 10% shareholding in Subic Water and Sewerage Co., Inc. ("Subic Water"), which serves 40,000 customers in Olongapo City and the Subic Bay Freeport Zone under a build-operate-transfer scheme.

CONSTRUCTION

The Group's construction business reported a sustained net income contribution of P1.28 billion in 2013. The segment was able to maintain its net income despite a slight decrease of 5% in revenues from external projects (outside of DMCI group) from P15.1 billion in 2012 to P14.4 billion in 2013. The sustained bottom-line is attributable to the improvement of margins of building projects.

From P15.7 billion as of end 2012, DMCI's total order book (balance of work) as of end 2013 amounted to P21.1 billion with the award of the NAIA Expressway project of San Miguel Corporation and the contract for the construction of the second 1 x 135 power plant of South Luzon Thermal Energy Corporation (SLTEC). Some of the notable projects the Company undertook during 2013 were the Entertainment City Project (completed in early 2013), the Entertainment City Phase 1A, the power plants in Batangas and the Tarlac Pangasinan La Union Expressway (TPLEX) Section 1B (Gerona to Pangasinan).

Although delayed, the Company is confident that the infrastructure development programs of the current Philippine government through the Public-Private Partnership (PPP) projects is already gaining headway and will inevitably materialize. It believes it is well positioned to be both a driver and a beneficiary of the country's infrastructure progress.

REAL ESTATE

The Group's real estate business is focused on residential development. It is led by the Company's wholly owned subsidiary DMCI Project Developer's Inc. (PDI) The segment posted a consistent 26% growth in net income reaching P2.7 billion in 2013 compared to P2.1 billion in 2012. Revenues also posted a robust 32% growth in 2013, amounting to P12.2 billion compared to P9.2 billion last year. Increase in revenue was moderated by higher cost and expenses due mainly to the increase in commissions paid and higher taxes and licenses expensed during the period.

It is worth to note that the company recognizes real estate revenues using the full accrual method, where sales are booked when the unit is fully completed and the downpayment of 15% has already been paid. Recently completed units in La Verti Towers, Flair Towers, Maricielo Villas, Royal Palm-Kamala, Tivoli Garden-Iris & Hibiscus, Siena Park and Rhapsody Residences significantly accounted for the growth in realized revenues.

A better representative of current demand would be sales and reservations for the period which experienced a 5% increase to P18.4 billion in 2013 from P17.5 billion in 2012, which covers Jan. to Dec. cutoff compared to previously reported P17.1 billion which is from Dec. 2011 to Nov. 2012 period to better align with financial statements reporting. Sustained demand for condominium units coming mainly from new projects: Levina Place, Lumiere Residences and Sheridan Towers, all in Pasig, Outlook Ridge in Baguio City, The Birchwood in Taguig and Vierra Residences in Quezon City pushed sales take-up higher. Moreover, increased take up from existing projects like Flair Towers, Tivoli Gardens, Verawood Residences, Zinnia Towers and Rhapsody Residences added to the growth in sales and reservations.

Taking advantage of a low interest environment, the PDI's bank loans reported a net increase of P6.4 billion, which is up 52% in end-2013. Loans are availed to finance land acquisitions and project expenditures as the company maintains its commitment to turnover its projects on time.

COAL MINING & POWER

Coal Mining & Power (Calaca-Coal)

The Company's coal mining business which owns a major power asset in Calaca are both lodged under the 56.32%-owned and publicly listed Semirara Mining Corp (SMC). SMC reported a decline in net income from P3.1 billion in 2012 to P1.8 billion in 2013. Mainly due to drop in Coal Revenues (net of eliminations), by 13% YoY at PHP12.57 billion from PHP14.45 billion in 2012 due to lower coal prices this year. This was countered by a surge in the net income coming from the power generation business amounting to P5.7 billion this year compared to P3.3 billion in the previous year due to higher energy generation capacity from the rehabilitated Calaca power plants.

Below is an excerpt from SMC's management discussion and analysis of results of operations and financial condition for the year 2013 as lifted from its consolidated financial report with the PSE and SEC:

A. MANAGEMENT'S DISCUSSION AND ANALYSIS OF FINANCIAL CONDITION AND RESULTS OF OPERATIONS (YEARS 2012-2013)

Full Years 2012-2013

I. PRODUCTION AND OPERATIONS

Coal

On 13 Feb 2013, at around 11:55 PM, a section of the west wall of Panian pit where the Company was concluding its mine operation gave way, affecting 13 personnel. Three have been rescued, five were confirmed dead, and five are still missing. Management immediately voluntarily stopped all mining activities in the site even before the receipt of notice from the Department of Energy (DOE) for stop operations.

On 5 March 2013, DOE issued clearance to the Company to do preparatory activities, excluding coal extraction, for the new area, the North Panian, after it has reviewed and evaluated the work program for the site.

Subsequently, on 19 April 2013, the Company received full clearance from DOE to proceed with the coal production activity. Since then, all mining operations have returned to normal.

The incident at the mine caused a temporary slump in coal mining operations. However, mining activities were able to catch up, such that total materials moved increased 7% YoY at 82.15 million bank cubic meters (bcm) from 77.07 million bcm last year. Strip ratio increased by 20% YoY at 9.73:1 from 8.66:1 last year. The increase is mainly due to the spike in strip ratio to 18.79:1 in Q1 after the Company stopped producing coal, but continued waste stripping. Run-of-mine (ROM) coal dropped by 5% YoY at 7.86 million metric tons (MTs) from 8.24 million MTs in 2012. A significant 45% drop YoY in washable coal at 727 thousand MTs from 1.31 million MTs last year was recorded as a result of improved coal quality. Net total product coal was almost the same at 7.62 million MTs and 7.63 million MTs in 2013 and 2012, respectively.

Total volume sold increased by 6% YoY at 7.63 million MTs from 7.18 million MTs last year. Coal shipments recorded an improvement in average heating value from 9,510 btu/lbs in 2012 to 9,676 btu/lbs. Coal ending inventory dropped by 8% YoY, closing at 1.28 million MTs from 1.38 million MTs last year as a result of higher sales volume.

The table below shows the comparative quarterly production data for 2013 and 2012.

COMPARATIVE PRODUCTION DATA											
<i>(in '000, except Strip Ratio)</i>											
	Q1 '13	Q2 '13	Q3 '13	Q4 '13	YTD '13	Q1 '12	Q2'12	Q3'12	Q4'12	YTD '12	%Inc (Dec)
Total Materials (bcm)	16,001	23,575	18,081	24,492	82,149	22,303	19,273	15,666	19,830	77,072	7%
ROM Coal (MT)	820	2,403	1,858	2,779	7,861	1,805	2,220	1,739	2,472	8,236	-5%
Strip Ratio	18.79:1	9.10:1	9.02:1	8.09:1	9.73:1	11.64:1	7.97:1	8.30:1	7.38:1	8.66:1	-10%
Net TPC (MT)	900	2,278	1,762	2,674	7,615	1,651	2,089	1,579	2,337	7,657	-1%
COAL WASHING											
Washable Coal (MTs)	83	254	195	195	727	344	334	358	278	1,314	-45%
Washed Coal (MTs)	50	153	117	117	436	206	200	215	167	788	-45%
%recovery	60%	60%	60%	60%	60%	60%	60%	60%	60%	60%	
Beg. Inventory (MTs)	1,383	460	1,137	1,311	1,383	992	950	963	1,276	992	39%
End Inventory (MTs)	460	1,137	1,311	1,277	1,277	950	963	1,276	1,383	1,383	-8%

Power

Total energy generation posted a record high in 2013 at 3,638 GWh, the highest in the history of the Calaca Coal Fired Thermal Power plants, posting a 48% YoY from 2,463 GWh in 2012.

Lower maintenance outage offset high forced outage of Unit 1 , raising total operating hours at 7,292 , 83% YoY from 2,697 hours in 2012 . Moreover, raised capacity of Unit 1 offset the lower dependable capacity of Unit 2, bringing average capacity to 501 MW from 446 MW last year.

Unit One

There is a notable improvement in 2013 as compared to previous year's performance. Average load of 229 MW is 16% above 2012's average load of 197 MW. This is primarily due to an increase in capacity ranging between 230 to 245 as a result of the use of Nalco Soot Remove 9F.

With higher operating hours at 7,292 hours, total generation is 1,667 Gwh, recording a 214% increase YoY compared to 2012's gross generation of 531 Gwh .

Capacity factor of 64% posted a significant 215% increase YoY from only 20% in 2012 as preventive maintenance of the plant drove availability down to 31% or operating hours of only 2,697.

Forced outage was high at 21% due to a leak in the condenser in Q2 and Q4 of 2013 caused by clogging in some of the tubes raising the temperature to increase beyond manageable level resulting to pin hole leaks .

To ensure that the sea water intake is free from any debris which may potentially cause another tube clogging incident, a preventive multi-layered net at sea and took on an active role in educating the neighboring communities on waste management.

Unit Two

The planned maintenance shutdown in December 2012 included six critical items, of which only five were executed. Replacement of Heaters 7 and 8 was deferred due to technical issue.

As a result, load was limited to 272 MW out of the rated capacity of 300 MW. This is however 9% higher than average capacity of 249 MW in 2012.

Despite the above limitation, gross generation posted a 2% increase YoY at 1,971 Gwh from 1,932 GWh in 2012.

Availability was however lower at 83% as against 88% in 2012.

The table below shows the comparative production data in 2013 and 2012.

COMPARATIVE PLANT PERFORMANCE DATA											
FY2013 VS FY2012											
	Q1'13	Q2 '13	Q3 '13	Q4 '13	FY'13	Q1 '12	Q2'12	Q3'12	Q4 '12	FY'12	% Inc (Dec)
Gross Generation, Gwh											
Unit 1	466	358	520	323	1,667	-	-	128	403	531	214%
Unit 2	351	525	512	584	1,971	473	478	508	473	1,932	2%
Total Plant	816	884	1,032	907	3,638	473	478	636	876	2,463	48%
% Availability											
Unit 1	95%	70%	98%	70%	83%	0%	0%	36%	87%	31%	171%
Unit 2	63%	86%	84%	97%	83%	88%	88%	92%	86%	88%	-6%
Total Plant	79%	78%	91%	84%	83%	44%	44%	64%	86%	60%	39%
Capacity Factor											
Unit 1	72%	54%	78%	49%	63%	0%	0%	19%	61%	20%	215%
Unit 2	54%	79%	77%	89%	75%	72%	72%	77%	72%	73%	2%
Total Plant	63%	67%	78%	0%	69%	36%	36%	48%	67%	47%	48%

II. MARKETING

Coal

Higher sales to power plants and exports offset drop in sales to cement plants and other industries. Total coal sales volume increased by 6% YoY at 7.63 million MTs from 7.18 million MTs last year.

The table below shows the comparative quarterly sales volume data for 2013 and 2012.

COMPARATIVE SALES VOLUME DATA													
<i>(in '000 MTs)</i>													
CUSTOMER	Q1 '13	Q2 '13	Q3 '13	Q4 '13	YTD '13	%	Q1 '12	Q2 '12	Q3 '12	Q4 '12	YTD '12	%	%Inc (Dec)
Power Plants													
Calaca	608	523	582	420	2,132	28%	205	285	545	456	1,492	21%	43%
Other PPs	256	216	159	159	790	10%	325	382	203	126	1,037	14%	-24%
TOTAL PPs	864	739	740	578	2,922	69%	531	667	748	582	2,528	63%	16%
Other Industries													
Cement	361	196	261	161	980	13%	272	338	224	220	1,053	15%	-7%
Others	92	89	68	79	328	4%	98	105	128	98	430	6%	-24%
Total Others	454	285	329	240	1,308	17%	370	443	352	318	1,482	21%	-12%
TOTAL LOCAL	1,318	1,024	1,070	818	4,230	55%	901	1,110	1,100	900	4,011	56%	5%
EXPORT	461	556	497	1,887	3,401	45%	771	946	146	1,310	3,173	44%	7%
GRAND TOTAL	1,778	1,581	1,567	2,705	7,631	100%	1,672	2,056	1,245	2,211	7,184	100%	6%

Sales to SCPC increased by 43% YoY at 2.13 million MTs from 1.49 million MTs last year as a result of increased capacity and availability of both power units after rehabilitation.

On the contrary, sales to other power plants dropped by 24% YoY at 790 thousand MTs from 1.04 million MTs last year. Drop in global coal prices encouraged some customers to import cheap coal from offshore market. Moreover, a customer has an outstanding shipping contract that it must utilize to transport coal from Indonesia.

Sales to cement plants likewise dropped 7% YoY at 980 thousand MTs from 1.05 million MTs due to decrease in offtake by a few customers this year.

Despite tapping two new customers this year, sales to other industries also dropped by 24% YoY at 328 thousand MTs from 430 thousand MTs. Some old customers decreased their offtake.

Strong export sales in the last quarter drove export share to 45% of the total pie this year. Total export sales of 3.40 million MTs is 7% higher than last year's 3.17 million MTs. Mining operations are concentrated in the area where coal quality is better, commanding higher export prices.

The 10% YoY decrease in composite average FOB price per MT at PHP2,185 from PHP2,454 last year reflected the drop in global coal prices.

POWER

Sales volume increased by 46% YoY at 3,460GWh from 2,365GWh in 2012. This is attributed to the higher energy generation of the newly rehabilitated power plants.

Of the total energy sold, 96% or 3,313 GWh were sold to bilateral contracts, while the remaining 4% were sold in the spot market.

Sales to bilateral contracts increased by 65% YoY at 3,313 GWh from 2,007 GWh in 2012. The improvement is due to increase of contract quantities for MERALCO from the initial 210 MW to 420 MW starting 31 January 2013, and the additional 30 MW non-firm contract capacity for TRANS-ASIA. The

non-firm additional contract capacity arrangement with Trans-Asia which is effective starting 16 February 2013, enables SCPC to sell its excess capacity at any given time.

MERALCO maintained to be the biggest customer of SCPC comprising 87% share of the total energy sales for SCPC's bilateral contracts, followed by Trans-Asia and Batelec I at 7% and 5% shares, respectively.

Spot market sales volume is lower at 148GWh in 2013 against 358 GWh in 2012. However Spot Sales Revenue in pesos is higher by 30% in 2013 vs 2012 due to the increase in the spot market prices in Q4.

Of the total energy sold, 99% was sourced from own generation and only 1% was purchased from the spot market. SCPC procured power from the spot market during hour intervals where power units were down, or were running at a derated capacity, in order to supply committed capacity to some of its customers. Contracts with some of its customer still cover the supply of replacement power under a "pass-thru" cost arrangement.

SCPC bilateral contracts yielded lower prices at an average price of PHP3.79 per KWh in 2013 compared to the PHP3.97 per KWh in 2012. This is due to lower prices of pass-thru coal fuel being indexed to the lower Newcastle prices in 2013.

On the other hand, average spot sales increased by 215% YoY at PHP14.98 per KWh from PHP4.75 per KWh in 2012. High spot prices in November and December pulled up price per KWh.

The table below shows the comparative sales volume data in 2013 and 2012.

COMPARATIVE SALES VOLUME DATA											
<i>(in GWh)</i>											
CUSTOMER	Q1 '13	Q2 '13	Q3 '13	Q4 '13	FY'13	Q1 '12	Q2'12	Q3'12	Q4'12	FY'12	% Inc (Dec)
Bilateral Contracts	751	838	966	757	3,313	489	427	518	573	2,007	65%
Spot Sales	20	10	17	100	148	1	1	79	278	358	-59%
GRAND TOTAL	771	849	983	858	3,460	489	428	597	851	2,365	46%
Composite Ave Price	3.89	3.91	3.66	5.65	4.26	4.14	4.41	3.73	4.15	4.09	4%

III. FINANCE

A. Sales and Profitability

Consolidated Revenues, net of eliminating entries, grew by 13% YoY at PHP27.33 billion as against PHP24.15 billion in 2012. Coal Revenues, before elimination, dropped by 5% YoY at PHP16.68 billion from PHP17.63 billion in 2012 due to lower coal prices this year. On the other hand, energy Revenues increased by 52% YoY at PHP14.76 billion from PHP9.7 billion last year as a result of the 46% increase in energy sales volume and 4% increase in average price per KWh.

Consolidated Cost of Sales decreased by 4% YoY at PHP14.11 billion from PHP14.64 billion last year.

Coal Cost of Sales before elimination declined by 5% YoY at PHP11.73 billion from PHP12.33 billion last year. Strip ratio normalized as at the end of the period from a historical high in Q1 as a result of the accident at the pit that temporarily halted coal extraction. Moreover, the Company implemented some cost-saving measures to counter the drop in coal prices, mining strategy only required shorter hauling

distance in North Panian while in-pit dumping allows the mine to decrease number of equipment while maintaining the same excavating capacity, thus 29 units of mining were put on stand-by. Net of elimination, Cost of Coal Sold also dropped by 12% YoY at PHP8.66 billion from PHP9.83 billion last year. Cost of Coal Sold per MT decreased by 10% YoY at PHP1,537 versus PHP1,716 last year.

Power Cost of Sales before elimination increased by 17% YoY at PHP6.51 billion from PHP5.55 billion; and 18% after elimination at PHP4.42 billion from PHP3.75 billion last year. Increase in volume sold accounted for the increase in total cost. Notably, Cost of Sales per KWh decreased by 25% at PHP1.88 from PHP2.35 last year due to minimal spot purchases for replacement power and lower coal fuel average cost this year.

The resulting consolidated Gross Profit in 2013 increased by 39% YoY at PHP13.22 billion with the coal and power segments each contributing PHP3.91 billion and PHP9.31 billion, respectively. Consolidated Gross Profit in 2012 stood at PHP9.51 billion, PHP4.63 billion from coal and PHP4.88 billion from power. Consolidated Gross profit margin improved at 48% from 39% last year.

Consolidated Operating Expenses increased by 55% YoY at PHP5.26 billion from P3.40 billion in 2012. Net of eliminating entries, the coal segment's Operating Expenses decreased by 17% YoY at PHP1.7 billion from last year's PHP2.0 billion. Lower coal Revenues decreased Government Share by 16% at PHP1.30 billion from PHP1.56 billion last year. Meanwhile, the power segment's Operating Expenses after elimination increased by 155% YoY at PHP3.5 billion from PHP1.4 billion last year due to acceleration of depreciation on certain equipment/components of Unit 2 whose repair are in-progress during the 90-day scheduled maintenance shutdown of Unit 2 which commenced last week of December 2013. These are to be replaced with new ones. Hence, the the carrying value of the affected equipment/components amounting to Php1.2 billion as of December 31, 2013 was fully provided with depreciation to reflect its true value in the books.

The pre-operating Southwest Luzon Power Generation Corp. (SLPGC), a wholly-owned subsidiary of the Company incorporated to expand its power capacity with the construction of 2 x 150 MW power plants, incurred PHP39.33 million pre-operating expenses, representing salaries and other administrative expenses incurred during the period. Other subsidiaries, Semirara Energy Utilities, Inc. (SEU), Semirara Claystone, Inc. (SCI) and Sem-Cal Industrial Park Developers, Inc (SCIPDI) also incurred Pre-operating Expenses of PHP100.5 thousand, PHP69.17 thousand PHP30.80 thousand for the period, respectively. Two new companies were incorporated during the period as vehicles for additional power expansion projects, they are San Rafael Power Generation Corp. (SRPGC) and Sem-Balayan Power Generation Corp. (SBPGC). Both companies incurred pre-operating expenses of PHP114.89 thousand and PHP194.62 thousand, respectively.

Consolidated Income from Operations increased by 30% YoY at PHP7.96 billion from PHP6.11 billion in 2012. The coal and power segments contributed PHP2.19 billion and PHP5.80, respectively this year, as against PHP3.30 billion and PHP2.27 billion in 2012. The other pre-operating companies, SLPGC, SEU, SCI, SCIPDI, SRPGC, SBPGC incurred losses of PHP39.33 million, PHP100.50 thousand, PHP69.17 thousand, PHP30.80 thousand, PHP114.89 thousand and PHP194.62 thousand, respectively.

As the USD strengthened against the PHP this year, the Company registered consolidated Forex Losses of PHP481.18 million as against Gains of PHP391.00 million last year. Since most of its loans are USD-denominated, bulk of the current period's Forex Losses is incurred by the coal segment which recorded PHP463.94 million losses versus last year's gains of PHP387.83 million. Of this amount, PHP305.93 million are unrealized losses. Meanwhile, with minimal Forex exposure, the power segment incurred Forex Losses of PHP15.49 million as against Gains of PHP3.17 million last year. SLPGC also recorded loss of PHP1.75 million on its foreign exchange transactions

Lower placement interest rates and lower free cash resulted to the decrease in consolidated Finance Income by 67% YoY at PHP26.80 million from PHP82.14 million last year. The coal segment's investible

funds reduced after using most of its cash for equity of SLPGC and to pay off debts toward the end of 2012, thus its Finance Income decreased by 67% at PHP26.80 million from PHP82.14 million last year. The power segment's Finance Income likewise decreased by 41% at PHP24.58 million from PHP41.53 million last year after using its cash to pay dividends of PHP2.5 billion during the the period. SLPGC recorded Finance Income of PHP217.06 thousand from short-term placements.

Consolidated Finance Costs decreased by 24% YoY at PHP381.23 million from PHP501.28 million. The coal segment's interest-bearing loans increased by 31% YoY, closing at PHP6.45 billion from PHP4.91 billion, increasing coal Finance Costs by 24% YoY at PHP152.63 million from PHP122.61 million. Meanwhile, the power segment's long-term loan balance dropped by 23% YoY to PHP5.34 billion from PHP6.91 billion last year thus bringing down power Finance Cost by 41% YoY at PHP221.61 million from PHP376.37 million last year. SLPGC incurred Finance Cost of PHP6.99 million for its project financing.

Consolidated Other Income dropped by 12% YoY at PHP281.21 million from PHP318.45 million. Bulk of last year's Other Income came from gain on sale of retired assets of the coal segment. Notably, the power segment's Other Income increased by 55% YoY at PHP203.18 million from PHP131.26 million last year. Power Unit 2 used more unwashed coal this year, producing more fly ash which is sold to a cement company at a higher price after renegotiating the supply contract on February 2012.

The resulting consolidated Net Income Before Tax (NIBT) increased by 16% YoY at PHP7.40 billion from PHP6.40 billion. SCPC accounted for 78% of the 2013's NIBT, at PHP5.79 billion after elimination. Meanwhile, net of eliminating entries, the coal segment generated NIBT of PHP1.66 billion, while the pre-operating SLPGC, SCI, and SEU, SCIPDI, SBGPC, and SRPGC incurred losses of PHP47.86 million, PHP64.45 thousand, PHP94.73 thousand, PHP32.26 thousand, PHP191.97 thousand, and PHP112.24 thousand, respectively. Before eliminations, power and coal recorded NIBT of PHP4.73 billion and PHP5.19 billion, respectively.

Both operating business units enjoy Income Tax Holidays (ITH) as Board of Investments-registered companies. As a result, the Company accounted for consolidated benefit from deferred income taxes of PHP117.84 million, net of final income taxes and income taxes for unregistered activities of PHP5.01 million and PHP11.69 million respectively. Last year's provision totaled to PHP39.60 million.

Consolidated Net Income After Tax (NIAT) increased by 18% YoY at PHP7.53 billion from PHP6.34 billion last year. Before eliminations, coal and power recorded NIAT of PHP5.34 billion, including PHP2.5 billion dividend income from power segment, and PHP4.71 billion, respectively. Meanwhile, after eliminations, the coal and power segments generated NIAT of PHP 1.80 billion, and PHP5.78 billion, respectively. SCI and SCIPDI also recorded a minimal income of PHP45.90 thousand and PHP19.65 thousand, respectively. On the other hand, SLPGC, SEU, SBGPC, and SRPGC incurred start-up costs of PHP47.90 million, PHP63.64 thousand, PHP192.5 thousand, and PHP112.77 thousand, respectively. Earnings per Share (EPS) correspondingly increased by 18% YoY at PHP21.11 from PHP17.85 last year.

POWER

An added growth area of the power segment is under DMCI Power Corporation, a wholly-owned subsidiary of the Parent Company. The company and its subsidiaries are focused on getting power supply contracts with the electric cooperatives situated in the off-grid areas.

As of December 31, 2013, the total installed rated capacity of the power generating units for Masbate and Palawan are 24.4MW (12.4 MW bunker-fired and 12 MW diesel) and 33.10 MW (diesel), respectively.

Power generation revenue from Masbate increased by 15% from P942 million in 2012 to P1.1 billion in 2013 while revenue from Palawan reached P371 million in 2013. Net income of Masbate went up by 160%, contributing P230 million in 2013 compared to P88.4 million in the same period of 2012 while Palawan contributed P23.6 million in net income for the full year 2013 compared to P0.80 million for only one month in 2012.

Nickel

The nickel and metals (non-coal) mining business, reported under DMCI Mining Corporation, posted a net income of P169 million in 2013, compared to last year's net income of P341 million. This was a combined effect of lower volume, ore grade and price compared to last year. Nickel ore shipments during 2013 substantially decreased to 316 thousand wet metric tons (WMT) from last year's 1.6 million WMT. Average sales price this year is at USD20 per WMT compared to last year's USD28 per WMT. Average nickel content of shipment this year is 1.65% compared to 1.71% last year.

Amidst continued weak global nickel ore price, DMCI Mining's margins have significantly declined, prompting the company to temporarily scale back the operations in the second half of 2013. Also, with the end of mining contract for Benguet in 2012 and the Acoje-ENK Mine having some transitory and permitting issues, DMCI Mining is looking at other opportunities for mine acquisition to enhance the segment's future operations.

Acquisitions

On February 15, 2013, DMCI Mining increased its stake to 37.7% in Toledo Mining Corporation PLC with the acquisition of an additional 20.7% for GBP 5.2 million. As a result, DMCI Mining launched a mandatory cash offer to acquire the entire issued and to be issued share capital of Toledo not already owned by DMCI Group. The offer comprised of 50 pence in cash for each Toledo share, valuing the whole of Toledo's existing issued share capital at approximately GBP 24.9 million. As of December 31, 2013, DMCI Mining has a total of 98.09% interest in TMC.

On March 25, 2014, the Parent Company acquired from D&A Income Ltd. the remaining 40% interest in ENK Plc for approximately P3.1 billion. Upon completion of the acquisition, ENK became a wholly owned subsidiary of the Parent Company.

As the Philippine Government is also looking to revamp and improve revenue generation and policy implementation in the mining industry, the Company sees this uncertain environment as an opportunity to possibly acquire more mining assets for the Group.

Cost of sales and Services

In spite of an 8% increase in consolidated revenues, cost of sales and services decreased by 1% due mainly to some cost-saving measures in the mining segments to counter the drop in coal and nickel ore prices. Increase in volume or units sold accounted for the increase in power and real estate cost of sales. The drop in construction costs of services outstripped the decline in construction revenue which is attributable to the improvement of margins of building projects.

Operating Expenses

Consolidated operating expenses increased by 44% primarily due to the corrective, preventive, and predictive maintenance program in Calaca Power, the acceleration of depreciation on certain equipment/components in Calaca Unit 2 and also the increase in commissions paid in the real estate segment.

Gain on Sale of Investment

This is the one-time gain (gross of tax) coming from the partial sale of the interest in Maynilad.

Equity in Net Earnings

Equity in net earnings amounted to P1.8 billion in 2013, 22% lower than last year. The drop was mainly due to the partial sale of the Company's interest in Maynilad.

Finance Income

Consolidated finance income decreased by 22% or P191 million mainly due to lower interest rates for short-term placements and more real estate customers availing of bank financing due to lower interest rates compared to in-house financing.

Finance Costs

Consolidated interest expense decreased by 22% or P269 million mainly due to lower borrowing rates and required capitalization of interest costs during construction period.

Other Income - Net

Consolidated other income decreased by 34% or P268 million mainly due to net foreign exchange loss recognized in 2013 amounting to P356 million compared to a net foreign exchange gain in 2012 amounting to P332 million.

Provision for Income Tax

Consolidated provision for income tax increased by 43% from P1.47 billion in 2012 to P2.10 billion in 2013 mainly caused by the tax on the partial sale of the interest in Maynilad and the increase in deferred provision for tax.

II. FINANCIAL CONDITION

December 31, 2013 – December 31, 2012

The Company's financial condition for the period improved as consolidated total assets and total net assets amounted to P123.8 billion and P60.2 billion as of December 31, 2013, posting an increase of 28% and 23%, respectively.

Consolidated cash increased by 155% from P9.7 billion in December 31, 2012 vs. P24.8 billion in December 31, 2013 due mainly to proceeds from the partial sale of interest in Maynilad. Moreover, cash generation from operations and loan drawdown also contributed to the increase in the year-end cash position.

Total available-for-sale financial assets (current and non-current) went down by 31% due to unrealized losses for quoted equity investments during the year.

Costs and estimated earnings in excess of billings on uncompleted contracts increased slightly by 7% mainly caused by construction contracts with cost and realized profits recognized in 2013 but contract billings will take place in future periods.

Total receivables (current and non-current) went up by 21% due mainly to normal trade in the businesses mostly coming from recognized receivable from newly completed project from real estate segment.

Consolidated inventories grew by 8% coming mainly from the land acquisitions and continuing work in progress in the real estate segment.

Other current assets increased by 31% mainly due to payment for advances to suppliers and time deposits with maturity of more than three months.

Investments in associates and joint ventures went down by 17% primarily as a result of the Company's partial sale of interest in Maynilad.

Consolidated net Property, plant and equipment grew by 22% as a result of the ongoing power expansion in Calaca.

Investment properties decreased by 2% mainly due to depreciation during the year.

Deferred tax assets increased by 751% mainly due to recognition of timing difference for unrealized foreign exchange losses.

Pension assets increased by 16% mainly as a result of higher reported fair value of plan assets which are primarily in debt and equity securities.

Other noncurrent assets grew by 106% mainly due to the increase in deferred input vat and third-party deposits such as rental security deposit.

Accounts & other payables increased by 12% mostly as a result of normal trade operations and accruals especially progress billings from subcontractors.

Customers' deposits increased by 47% due to payments received from real estate customers the revenue of which has yet to be realized.

Billings in excess of costs and estimated earnings on uncompleted contracts increased by 10%. This was caused by construction contract billings in 2013 which preceded cost and profit recognition.

Liabilities for purchased land increased by 20% mainly due to acquisition of certain land properties which are payable over a period of two to four years.

Short-term debt increased by 100% due to availment by the coal segment of short-term working capital loans during the period.

Income tax payable decreased by 17% from P89 million to P66 million due payments made during the year and application of creditable withholding tax.

Payable to related parties decreased by 9% from P61 million to P34 million mainly caused by the settlement of transactions during the year.

Long-term debt grew by 40% primarily due to drawdown of project financing facilities in the power segment and the receipt of additional tranches of corporate notes in the real estate segment.

Deferred tax liabilities increased by 33% due to additional reconciling items particularly excess of book over tax income pertaining to construction contracts and real estate sales.

Pension liabilities increased by 9% from P86 million to P94 million as a result of additional pension expense from actuarial valuation.

Other noncurrent liabilities increased by 11% mainly due to the coal segment's increase in mine rehabilitation contingency.

Retained earnings grew by 29% primarily due to the consolidated net income share of DMCI shareholders.

Non-controlling interest increased by 20% as a result of the non-controlling interests' share in the consolidated net income of Semirara, net of its share in the dividends declared during the period.

III. KEY PERFORMANCE INDICATORS

The Company and its Subsidiaries (the “Group”) has the following as its key performance indicators:

- a) Segment Revenues
- b) Segment Net Income (after non-controlling interests)
- c) Earnings Per Share
- d) Current Ratio
- e) Debt to Equity Ratio

SEGMENT REVENUES

<i>(in Php Millions)</i>	Audited		Variance	
	2013	2012	Amount	%
COAL SALES	P12,573	P14,450	(P1,877)	-13%
NICKEL ORE SALES	265	1,923	(1,658)	-86%
CONSTRUCTION	14,360	15,068	(708)	-5%
REAL ESTATE	12,166	9,219	2,947	32%
POWER	16,607	11,080	5,527	50%
PARENT COMPANY	-	-	-	-
TOTAL	P55,971	P51,740	P4,231	8%

The initial indicator of the Company’s gross business results are seen in the movements in the different business segment revenues. As illustrated above the significant main drivers for revenue growth are the power and real estate segments. Revenues from the mining businesses are down due to weak global prices and temporary scale down of nickel mining operations (*see Part I. Results of Operations – different segments for a detailed discussion per business*).

SEGMENT NET INCOME AFTER NON-CONTROLLING INTERESTS

<i>(in Php Millions)</i>	Audited		Variance	
	2013	2012 (as restated)	Amount	%
COAL MINING	P1,022	P1,740	(P718)	-41%
NICKEL MINING	169	341	(172)	-50%
CONSTRUCTION	1,275	1,275	-	0%
REAL ESTATE	2,655	2,105	550	26%
POWER	3,478	1,901	1,577	83%
WATER	1,915	2,340	(425)	-18%
PARENT COMPANY	65	34	31	91%
CORE NET INCOME	10,579	9,736	843	9%
ONE-TIME GAIN ON SALE (<i>Parent</i>)	8,358	-	8,358	-
TOTAL	P18,937	P9,736	P9,201	95%

The net income (after non-controlling interests) or bottom line results from operations of the Company can be seen with the increment in net income for the period compared to the same period of the previous year for domestic-oriented businesses. For 2013, power and real estate posted strong growth in earnings

while coal and nickel mining reported steeped declines due to weak global commodity prices (see Part I. Results of Operations – different segments for a detailed discussion per business).

EARNINGS PER SHARE

The Company's consolidated earnings per share (EPS) for the year was P7.13/share accounting for a 93% increase from the P3.67/share EPS last year. Same as segment net income, the power and real estate segments mainly contributed to the improvement in net earnings (see Part I. Results of Operations – different segments for a detailed discussion per business).

CURRENT RATIO

Liquidity is an essential character of any organization, and the Company, including the Group as a whole, should indicate acceptable levels of liquidity. The initial test of liquidity is the current ratio, which will display a company's ability to satisfy current obligations with current resources. Current ratio is arrived by dividing the current assets over the current liabilities. The Company uses this test and compares it with industry balances to determine its ability to satisfy current obligations with respect to its competitors (see Part II. Financial Condition for a detailed discussion).

DEBT TO EQUITY RATIO

As a stockholder/investor, financial position and stability would be an important aspect. The Company tests its financial position through the debt to equity ratio. This test indicates the Company's ownership of creditors vs. owners/investors. In addition, debt to equity ratio maintenance is a requirement set by creditors as a standard for extending credit. Debt to equity ratio is computed by dividing the total liabilities over total equity (see Part II. Financial Condition for a detailed discussion).

OTHER RELEVANT FINANCIAL SOUNDNESS RATIOS		
	Dec. 31 2013	Dec. 31 2012
Current Ratio	247%	180%
Debt to Equity Ratio	61%	52%
Interest Coverage Ratio	2,621% 1,636%*	1,165%
Return on Assets Ratio	20% 13%*	14%
Return on Equity Ratio	41% 26%*	28%
Asset to Equity Ratio	206%	199%
Gross Margin Ratio	39%	33%
Net Profit Margin Ratio	40% 25%*	24%

*excluding one-time gain from Maynilad partial sale

B. OTHER INFORMATION

1. The company's operation is a continuous process. It is not dependent on any cycle or season;
2. Economic and infrastructure developments in the country may affect construction business; Interest rate movements may affect the performance of the real estate industry; Mining activities are generally hinge on the commodities market. Businesses not affected by known cycle, trends or uncertainties are power and water.
3. On April 11, 2013, the Parent Company has declared cash dividends amounting P1.20 regular dividends and P1.00 special cash dividends in favor of the stockholders of record as of April 26, 2013. This was paid on May 10, 2013 with the total amount of P5,842.09 million. On November 14, 2013, the Parent Company declared additional P1.20 special cash dividends to stockholders of record as of November 29, 2013. This was paid on December 13, 2013 with the total amount of P3,186.59. Total cash dividends declared during the year amounted to P3.4 per share or a total amount of P9,028.68.
4. There were no undisclosed material subsequent events and transferring of assets not in the normal course of business that have not been disclosed for the period that the company have knowledge of;
5. There are no material contingencies during the year; any event that may trigger direct or contingent financial obligation that is material to the company, including any default or acceleration of an obligation has been disclosed in the notes to financial statements.
6. There are no material off-balance sheet transactions, arrangements, obligations (including contingent obligations), and other relationships of the company with unconsolidated entities or other persons created during the reporting period
7. Except for interest payments on loans, which the Company can fully service, the only significant commitment that would have a material impact on liquidity are construction guarantees. These are usually required from contractors in case of any damage / destruction to a completed project.
8. Any known trends or any known demands, commitments, events or uncertainties that will result in or that will have a material impact on the registrant's liquidity. - **None**
9. The Group does not have any offering of rights, granting of stock options and corresponding plans therefore.

C. MANAGEMENT'S DISCUSSION AND ANALYSIS OF PLAN OF OPERATION.

Full Year 2012 vs. 2011

J. RESULTS OF OPERATIONS

DMCI Holdings, Inc. (the "Company") reported a net income after non-controlling interests of P9.8 billion for the year 2012, which is 2.0% higher than the P9.6 billion recorded during the previous year. Consolidated revenues reached P51.8 billion, which is 8.4% higher year-on-year, primarily driven by the growth in construction, real estate and power generation revenues. With the significant drop in the global price of nickel ore, the increase in cost of construction materials and labor, and the lower average coal price, net income showed a modest increase compared to revenue.

Below is a table on the net income contributions of the Company's businesses for 2012 and 2011:

**NET INCOME AFTER
NON-CONTROLLING INTERESTS**

<i>(in Php Millions)</i>	Audited		Variance	
	2012	2011	Amount	%
COAL SALES	P1,739	P2,379	(P640)	-27%
NICKEL ORE SALES	341	917	(576)	-63%
CONSTRUCTION	1,220	1,117	103	9%
REAL ESTATE	2,182	1,795	387	22%
ELECTRICITY	1,902	1,177	725	62%
WATER	2,264	2,195	69	3%
PARENT & OTHERS	144	15	129	860%
TOTAL	9,792	9,595	197	2%

Due to the significant fall in commodity prices of nickel and coal, the mining segments posted declines in net income contributions. This was countered by robust performances of the real estate and power generation segments driven by a buoyant housing market and increased generation capacity coming from the newly rehabilitated power units. The construction segment also bounced back from 2011 with a 9% increase in 2012, resulting from higher recognized revenues from project completion and a healthy portfolio of projects. The equity in net earnings coming from the water business registered modest growth due to a 5.8% increase in water billed volume and an average year-on-year effective tariff increase of 9.2%.

WATER

The Company's investment in the water sector is recognized through its 44.59% equity investment in DMCI-MPIC Water Company, Inc. (DMWC), the consortium company, with Metro Pacific Investments Corp. (MPIC), which owns 91.90% of Maynilad Water Services, Inc. (Maynilad). Maynilad handles the water distribution and sewer services for the western portion of Metro Manila and some areas of Cavite. For 2012, water investment contributions reached P2.3 billion, up by 3.1% from the previous year.

Maynilad operations reported better efficiencies for 2012 vs. 2011. For the year 2012, Maynilad grew its billed volume by 5.8% to 428.4 million cubic meters (MCM) versus the 404.7 MCM billed in the prior year. With billed volume continuing to grow despite an effective 2.3% reduction in supply, average NRW for the year improved to 43.5% from 47.8% in the prior year. Continued expansion into the southern areas of Muntinlupa, Las Piñas and Cavite brought connections up to a total of 1,073,508 billed services, a 6.8% growth from the end of the same period last year, but lower than the 11.3% growth registered in 2011 due to right-of-way and permitting issues in Cavite. Renewed efforts by the company to clean up non-performing accounts also contributed.

Combined revenues from water and sewer services for the year grew 15.6% to P15.4 billion from P13.3 billion last year. The increase in revenues was due to the combined effect of the 5.8% increase in billed volume coupled with a 9.2% increase in average effective tariff. The effective rate increase for the year was dampened, not only by the deferred implementation of the higher rate until August, but also by the higher proportion of billed volume growth coming from domestic consumption whose rates are subsidized.

Meanwhile, total cash opex increased by 16.5% to P4.6 billion versus P4 billion last year. The four largest cost elements accounting for almost 73% of total cash expenditures continue to be personnel cost, light and power, outside services, and repairs and maintenance. Total non-cash operating expenses increased by P271 million or 14.6% to P2.1 billion from P1.9 billion last year. Due to the company's

continuing capital expenditure program, amortization of intangible assets increased 27.3% to P1.8 billion from P1.4 billion in the prior year.

As a result, net income, grew at a rate of 8.9% to P6.4 billion from P5.9 billion in the prior year. The Company's net share in the equitized earning from its water investment in Maynilad for the year reported only P2.3 billion due to the adjustments at the consortium company level.

As part of its strategic business expansion, Maynilad and Philippine Hydro Inc. (PhilHydro) signed the Share Purchase Agreement (SPA) on August 3, 2012 for the acquisition of 100% shares of PhilHydro by Maynilad. PhilHydro owns and operates three plants that supply treated bulk water to the Legazpi City Water District in Albay, Norzagaray Water District and Santa Maria Water District in Bulacan, and municipal waterworks of Bambang, Nueva Vizcaya. The company also owns and operates the treated water supply and distribution system of Rizal, Nueva Ecija.

On December 28, 2012, DMWC subscribed for 134,023 common shares of stock of Maynilad at a total subscription price of P134.0 million, subject to the terms and conditions of the subscription agreement. On January 31, 2013, the SEC approved Maynilad's increase in authorized capital stock.

On December 28, 2012, MCNK JV Corporation (MCNK) subscribed for 169,617,682 common shares of stock (the "Subscription Shares") of the consortium company at a total subscription price of P169.6 million, subject to the terms and conditions of the subscription agreement. On January 29, 2013, the SEC approved DMWC's increased in authorized capital stock.

MCNK is 90.0% owned by Marubeni Corporation, a company incorporated in Japan and 10% owned by MAPL Holdings B.V., a company incorporated in Netherlands.

At the end of 2012, Maynilad determined that it is no longer appropriate to continue using the straight-line basis for amortizing concession assets given the large initial investments and that the economic benefit of these assets are more closely aligned with billed volume. Maynilad's BOD approved the change in amortization method to units-of-production resulting in deferred tax asset write-off amounting to P592.0 million in 2012.

CONSTRUCTION

The Group's construction business posted better results as segment net income after non-controlling interests reached P1.2 billion this year compared to P1.1 billion last year, an increase of 9% year-on-year. Revenues significantly grew by 44% year-on-year to P14.8 billion this year compared to P10.3 billion last year. This was mainly due to billable works done for the building projects. Notable accomplishments are Solaire Resorts and Casino and The Raffles Suites and Residences which provided most of the boost in revenues. This however yielded relatively less margins, as building contracts generally have lower margins due to stiffer competition and higher materials and subcontracting costs compared with the specialized and complicated infrastructure projects. With the activity for the year coming mainly from the building contracts, construction gross and net profits showed only modest increases.

With the completion of the big building projects in 2012, DMCI's orderbook (balance of work) as of end-2012 amounted to P15.7 billion coming from a P22.2 billion end-2011 balance. The bulk of the balance of work is coming from the power plant construction contracts in Batangas, which comprise P5.5 billion from Semirara's 2x150MW Calaca expansion and P3.2 billion from South Luzon Thermal Energy Corp's 1x135MW. The orderbook however, does not include the MRT-7 railway project, which was already awarded to DMCI but still pending financial closing. Power plant-civil works projects in Calaca and Balayan, Batangas are expected to contribute in the continuing growth of construction revenue.

Although delayed, we believe the infrastructure development programs of the current Philippine government thru the Public-Private Partnership (PPP) projects will inevitably materialize. As such, the Company, thru DMCI, is very much interested in the construction and engineering of these initiatives. The Company believes it is well positioned to be both a driver and a beneficiary of the country's infrastructure progress.

REAL ESTATE

The Group's real estate business is focused on residential development. It is led by the Company's wholly owned subsidiary DMCI Project Developer's Inc. The segment posted a 22% growth in net income on the back of a 12% increase in recognized revenues year-on-year, reaching P9.2 billion this year compared to P8.3 billion last year. It is worth to note that the company recognizes real estate revenues using the full accrual method, where sales are booked when the unit is fully complete and the downpayment of 15% has already been paid. Recently completed units in the Accolade Place, Maricielo Villas, Royal Palm-Rawai, Sienna Park, and Tivoli Gardens-Iris projects significantly accounted for the growth in realized revenues. Revenue growth outpaced the increase in expenses, resulting in net margin improvements brought about by continued cost containment effects. With corporate costs remaining under control, the ratio of general and administrative expenses, inclusive of brokers' commissions, to revenues was lowered at 19% compared to 20% last year.

Amidst the presence of aggressive competition within its market, sales and reservations take up for the year was sustained at P17.1 billion, equivalent to an average monthly take up of P1.4 billion, same in 2011. This is a testament to the strong niche the company has developed within its class as it continued to post brisk sales despite being purely concentrated on a specific market.

With the current increase of VAT-free housing price threshold to around P3.2 million, the Company has leveraged on the tax advantage to become more price competitive in the market. Notably, most of the Company's housing units have a selling price of around P3 million per unit.

In October 2012, the Company recently signed a facility agreement with a group of primary institutional lenders for DMCI PDI's issuance of Php 10.0 billion in 7-year Fixed Rate Corporate Notes (Notes). The proceeds from the Notes issue shall be used to finance project development and construction costs, acquire real estate properties, and fund other general corporate purposes.

COAL MINING & POWER

Coal Mining & Power (Calaca-Coal)

The Company's coal mining business which owns a major power asset in Calaca are both lodged under the 56.32%-owned and publicly listed Semirara Mining Corp (SMC). SMC reported a decline in net income of P3.1 billion compared to P4.1 billion last year. Mainly due to lower average coal prices despite a 10% increase in coal sales volume. This was countered by a surge in the net income coming from power generation of P3.3 billion compared to P1.9 billion in the previous year due to higher energy generation capacity from the newly rehabilitated Calaca power plants.

Below is an excerpt from SMC's management discussion and analysis of results of operations and financial condition for the year 2012 as lifted from its consolidated financial report with the PSE and SEC:

A. MANAGEMENT'S DISCUSSION AND ANALYSIS OF FINANCIAL CONDITION AND RESULTS OF OPERATIONS (YEARS 2011-2012)

Full years 2011-2012

I. PRODUCTION AND OPERATIONS

COAL

Total materials moved in 2012 decreased by 9% at 77,072,255 from 85,060,883 bank cubic meters (bcm) last year due to longer hauling cycle and lower operating days. During the year, mining operations were concentrated at the lowest level of the pit, thus resulting to longer hauling cycle. Meanwhile, total rainfall this year of 2,771 mm is 2% lower than last year.

The advance stripping activities in the previous periods benefit the current period's mining operations as activities in 2012 were more focused on coal production rather than overburden stripping. As a result, strip ratio dropped by 15% at 8.66:1 from 10.13:1 last year. This explains the 5% increase in run-of-mine (ROM) coal production at 8,235,875 metric tons (MTs) from 7,840,467 MTs last year, despite the decrease in material movement. Coal recovery improved with the sale of unwashed coal to subsidiary Sem-Calaca Power Generation Corporation (power segment) for the use of its Unit 2. Hence, net total product coal increased by 8% at 7,656,849 MTs from 7,118,460 MTs last year.

Ending inventory increased by 39% at 1,382,607 MTs from beginning inventory of 991,887 MTs also as a result of higher coal recovery.

The table below shows the quarterly comparative production data for 2012 and 2011.

COMPARATIVE PRODUCTION DATA											
<i>(in '000, except Strip Ratio)</i>											
	Q1 '12	Q2 '12	Q3 '12	Q4 '12	YTD '12	Q1 '11	Q2 '11	Q3 '11	Q4 '11	YTD '11	%Inc (Dec)
Total Materials (bcm)	22,303	19,273	15,666	19,830	77,072	26,850	22,294	16,120	19,797	85,061	-9%
ROM Coal (MT)	1,805	2,220	1,739	2,472	8,236	1,822	2,296	1,837	1,887	7,840	5%
Strip Ratio	11.64:1	7.97:1	8.30:1	7.38:1	8.66:1	14.03:1	9.00:1	8.06:1	9.78:1	10.13:1	-15%
Net TPC (MT)	1,651	2,089	1,579	2,337	7,657	1,642	2,149	1,646	1,682	7,118	8%
COAL WASHING											
Washable Coal (MTs)	344	334	358	278	1,314	408	313	434	470	1,625	-19%
Washed Coal (MTs)	206	200	215	167	788	245	188	261	282	975	-19%
%recovery	60%	60%	60%	60%	60%	60%	60%	60%		60%	
Beg. Inventory (MTs)	992	950	963	1,276	992	491	469	74	237	491	102%
End Inventory (MTs)	950	963	1,276	1,383	1,383	469	74	237	992	992	39%

POWER

UNIT 1

When Calaca Power Plant assets were acquired in December 2009, Unit 1 can only generate 160 MW or 53% of its rated capacity using pure Semirara Coal. The rehabilitation of the unit was centered on improving the loading capacity to at least 220 MW or 73% of its rated capacity.

The rehabilitation of the plant started in August 2011 and completed in July 2012. It took more than a year of planning to cover all major repair works. The rehab project suffered delays in the commissioning stage to ensure the safe and reliable operation of the plant. The original equipment manufacturers

(OEMs), Foster Wheeler for the boiler and Toshiba for the Turbine/Generator, supervised the repair to commissioning of the Unit. Although delayed, the unit can now load 235 MW or 77% of its rated capacity, an improvement of 24% or 75 MW on pure Semirara Coal.

Generation capacity is low at 20% in the five months of running against 27% last year but the average load is significantly higher at 197 MW against 155 MW. In general, the unit is now better in terms of generation capacity and efficiency.

Unit availability was only 2,697 hours or 31% compared to 54% last year since Unit 1 was down for about 7 months during the current period due to the rehabilitation works. Total energy generated was 531 Gwh or 27% down compared to last year.

UNIT 2

Unit 2 is on its second year of operation after its rehabilitation in the last quarter of 2010.

The unit performed better this year in all aspects of operation compared to last year. Gross generation has increased by 71% or 1,932 Gwh. Unit availability improved from 60% to 88% and force outage was limited to only 12% from 36% last year. Running hours in 2012 is remarkably higher at 7,761 hours than 2011 48% increase.

Loading capacity is limited to 260 MW due to some leaks on two of its high pressure heaters 7 & 8. The average load capacity during the current period is at 249 MW or 20% more than last year.

The table below shows the quarterly comparative plant performance for 2012 and 2011.

COMPARATIVE PLANT PERFORMANCE DATA											
YTD'12 vs YTD'11											
	Q1 '12	Q2 '12	Q3 '12	Q4 '12	YTD '12	Q1 '11	Q2'11	Q3'11	Q4'11	YTD '11	% Inc (Dec)
Gross Generation, Gwh											
Unit 1	-	-	128	403	531	243	245	239	-	727	-27%
Unit 2	473	478	508	473	1,932	189	395	181	367	1,132	71%
Total Plant	473	478	636	876	2,463	432	641	420	367	1,860	32%
					-					-	
% Availability											
Unit 1	0%	0%	36%	87%	31%	70%	74%	70%	0%	54%	-43%
Unit 2	88%	88%	92%	86%	88%	49%	83%	37%	71%	60%	48%
Total Plant	44%	44%	64%	86%	60%	59%	78%	54%	35%	57%	5%
Capacity Factor											
Unit 1	0%	0%	19%	61%	20%	0%	0%	36%	0%	28%	-27%
Unit 2	72%	72%	77%	72%	73%	29%	60%	27%	56%	43%	70%
Total Plant	18%	18%	24%	33%	47%	17%	24%	16%	14%	35%	32%

II. MARKET

COAL

Total coal sold in 2012 increased by 10% at 7.18 million MTs compared to 6.52 million MTs in 2011. Q1 2012 sales of 1.67 million MTs was 2% higher than 1.64 million MTs sold in Q1 2011, however, Q2 2012 sales volume of 2.06 million MTs was 18% lower as against 2.52 million MTs in Q2 2011, while Q3 sales continued to drop by 15% at 1.25 million MTs this year from 1.46 million MTs in 2011. Q4 sales recovered with an increase of 145% at 2.21 million MTs from 902 thousand MTs last year.

The table below shows the quarterly comparative coal sales volume data for 2012 and 2011.

COMPARATIVE SALES VOLUME DATA													
(in '000 MTs)													
CUSTOMER	Q1 '12	Q2 '12	Q3 '12	Q4 '12	YTD '12	%	Q1 '11	Q2 '11	Q3 '11	Q4 '11	YTD '11	%	%Inc (Dec)
Power Plants													
Calaca	205	285	545	456	1,492	21%	412	320	420	256	1,408	22%	6%
Other PPs	325	382	203	126	1,037	14%	384	325	569	270	1,547	24%	-33%
TOTAL PPs	531	667	748	582	2,528	63%	795	645	989	525	2,955	72%	-14%
Other Industries													
Cement	272	338	224	220	1,053	15%	187	145	146	182	660	10%	59%
Others	98	105	128	98	430	6%	197	60	107	111	475	7%	-9%
Total Others	370	443	352	318	1,482	21%	384	205	254	292	1,135	17%	31%
TOTAL LOCAL	901	1,110	1,100	900	4,011	56%	1,180	850	1,242	818	4,090	63%	-2%
EXPORT	771	946	146	1,310	3,173	44%	462	1,665	218	85	2,430	37%	31%
GRAND TOTAL	1,672	2,056	1,245	2,211	7,184	100%	1,641	2,516	1,460	902	6,519	100%	10%

Sale to power plants decreased by 14% this year at 2.53 million MTs from 2.96 million MTs last year. Although Q1 and Q2 off-take of the power segment were lower this year as compared to last year as rehabilitation of Unit 1 was completed only in Q3, coal off-take increased in the second half. As a result, the power segment's total coal purchases increased by 6% at 1.49 million MTs this year from 1.41 million MTs last year. Meanwhile deliveries to other power plants dropped in the second half, resulting to a 33% drop YoY at 1.04 million MTs this year from 1.55 million MTs in 2011.

On the other hand, with three new customers this year, sales to cement plants increased by 59% at 1.05 million MTs from 660 thousand MTs last year.

The 9% drop in sales to other local customers was mainly caused by weaker purchases by some small traders in Q1 and Q4 this year. Deliveries to other industrial plants totaled to 430 thousand MTs from 475 thousand MTs in 2011.

The increase in sales to cement plants helped offset the decrease in deliveries to power plants and other industrial customers, thus softening the drop in total local sales at 2% to 4.01 million MTs this year from 4.09 million MTs in 2011.

On the other hand, export sales rebounded in Q4, bringing total exports to 3.17 million MTs this year or a 31% growth from last year's 2.43 million MTs.

All supply contracts with the Corporation are already priced at market. As a result, the drop in global coal prices brought down composite average FOB price per MT this year to PHP2,453, a 20% decrease from last year's PHP3,078.

POWER

The power segment's 2012 recorded sales for bilateral contracts increased to 2,007 GWh from 1,553GWh in 2011 or 29% improvement. This mainly came from the contract with MERALCO which was effective since 26 December 2011.

MERALCO is still the single biggest customer of the power segment in 2012, accounting for 80% share of the total energy sales to bilateral contracts. BATELEC I and Trans-Asia accounted for 12% and 6% market share, respectively, the balance is for other small contracts.

Meanwhile, spot market sales dropped by 26% from 472 GWh in 2011 to 348 GWh in 2012. The decrease in spot sales was due to the increase in contracted power which effectively reduced the excess capacity for sale in the spot market.

Total energy sold in 2012 posted at 2,355 GWh 85% directly to the customers through bilateral contracts, and 15% to the spot market. Total energy sales increased by 16% from 2,025 GWh recorded in 2011.

Of the total energy sold, 99% was sourced from the generation of the power plants, while 1% was purchased from the spot market.

Spot market prices in 2012 were more volatile compared to 2011. This is due to the abrupt forced outages and scheduled maintenance of major power plants which decreased the supply in the months of May to July 2012. Also, It was observed that the demand increased by an average of 4% in 2012. These two factors caused the increase of spot prices in the market.

In the last quarter of 2012, spot prices escalated due to the planned outages of Ilijan Block A (600 MW) and Sta. Rita Mod 30 (256 MW) amidst the increased demand as business activities stepped up until Christmas Eve. This situation in the market provided Unit 1 an opportunity to generate more Revenues as power generated during the plant's testing were sold to the spot market.

The table below shows the quarterly comparative sales volume data and composite average price for 2012 and 2011.

COMPARATIVE SALES VOLUME DATA											
<i>(in GWh)</i>											
CUSTOMER	Q1'12	Q2'12	Q3'12	Q4'12	YTD'12	Q1'11	Q2'11	Q3'11	Q4'11	YTD'11	%Inc (Dec)
Bilateral Contracts	489	427	518	573	2,007	362	457	398	336	1,553	29%
Spot Sales	0.59	1	68	278	347	94	215	75	88	472	-26%
GRAND TOTAL	489	428	586	851	2,354	456	671	474	425	2,025	16%
Composit Ave Price	4.14	4.41	3.79	4.19	4.12	4.58	4.79	4.51	5.12	4.75	-13%

III. FINANCE

A. Sales and Profitability

Consolidated Revenues, net of eliminating entries, dropped by 6% YoY at PHP24.15 billion from PHP24.81 billion last year. Although coal sales volume increased, lower composite average price/MT pulled down coal Revenues before elimination to PHP17.63 billion this year from PHP20.06 billion last year. Net of eliminations, Coal Revenues dropped by 11% YoY at PHP14.45 billion from PHP16.20 billion last year. On the other hand, higher energy generation offset the decrease in average price per kwhr caused by the decrease in international coal price index. As a result, energy sales slightly improved by 1% at PHP9.70 billion from PHP9.61 billion last year.

Consolidated Cost of Sales decreased by 12% at PHP14.64 billion from PHP16.66 billion last year. Before elimination, Cost of Coal Sold dropped by 12% at PHP12.33 billion from PHP14.01 billion last year due to lower cost/MT sold. Net of elimination, Cost of Coal Sold likewise dropped by 12% YoY at PHP9.82 billion from PHP11.10 billion. Cost of Coal Sold per MT dropped by 24% compared to last year due mainly to higher units of production and tightening control on some mine overhead costs. This partially offsets the decline in Revenues due to lower average coal prices.

In the same note, power Cost of Energy Sales before elimination reduced by 14% at PHP5.55 billion from PHP6.40 billion last year. Minimal spot purchases for replacement power and lower coal fuel average cost this year accounted for the decrease in cost.

The resulting consolidated Gross Profit increased by 4% at PHP9.51 billion, with the coal power segments each contributing PHP4.63 and PHP4.88 billion, respectively. Last year's consolidated Gross Profit stood at PHP9.15 billion last year, PHP5.10 billion from coal and PHP3.05 billion from power. Consolidated Gross profit margin improved to 39% from 35% last year.

Consolidated Operating Expenses increased by 19% at PHP3.39 billion from PHP2.86 billion last year. Net of eliminating entries, the coal segment's Operating Expenses increased by 9% at PHP2.0 billion from last year's PHP1.84 billion as lower Cost of Sales increased Government Share by 5% at PHP1.56 billion from PHP1.48 billion last year. The power segment's Operating Expenses after elimination also

went up by 35% at PHP1.38 billion from PHP1.02 billion last year due to write-down of net book value of replaced major components and parts relative to the rehabilitation of Unit 1 amounting to PHP341 million. The pre-operating Southwest Luzon Power Generation Corp. (SLPGC), a wholly-owned subsidiary of the Corporation incorporated to expand its power capacity with the construction of 2 x 150 MW power plants, incurred PHP21.55 million pre-operating expenses, representing taxes, licenses and fees incurred during the year. Another subsidiary, Sem-Cal Industrial Park Developers, Inc. (SIPDI) and Semirara Claystone Inc. also incurred Pre-operating Expenses of PHP37 thousand and PHP65 thousand during the period, respectively.

Consolidated Forex Gains posted a remarkable PHP391 million as against losses of PHP38.32 million last year. The PHP continued to strengthen against the USD during the year. Since most of its loans are USD-denominated, bulk of this year's Forex Gains is attributed to the coal segment which recognized PHP387.83 million versus last year's Loss of PHP26.01 million. Meanwhile, with minimal Forex exposure, the power segment's Forex Gains registered at PHP3.17 million as against Losses of PHP12.31 million last year.

Lower cash and lower placement interest rates resulted to the decrease in consolidated Finance Income by 39% at PHP82.15 million from PHP134.88 million last year. The coal segment's investible funds reduced after its additional equity infusion of PHP2.5 billion to SLPGC, thus its Finance Income decreased by 83% at PHP13.12 million from PHP79.45 million last year. On the other hand, the power segment's Finance Income increased by 24% at PHP68.95 million from PHP55.43 million due to higher short-term placement income from SLPGC in the first half of 2012 with its higher cash level, coming from the proceeds of the initial drawdown from the project loan facility and equity infusion by the parent, parked in short-term placements.

Consolidated Finance Costs slightly increased by 4% at PHP501.28 million from PHP483.29 million last year. The coal segment's interest-bearing loans increased by 6% at PHP4.91 billion from PHP4.62 billion last year. Although interest rates are lower this year, Finance Costs increased by 17% at PHP122.61 million from PHP104.93 million last year as it only started paying off short-term debts toward the end of the year. Meanwhile, the power segment's total ending interest-bearing loans balance dropped to PHP7.35 billion from PHP8.84 billion last year. Of this amount, P550 million reflects the new availment by SLPGC. With the availment of short-term working capital loans during the year, the power segment's Finance Costs slightly increased at PHP378.67 million from PHP378.36 million last year.

Consolidated Other Income increased by 219% at PHP318.45 million from PHP99.91 million generated by the coal segment last year from gain on sale of retired assets. After eliminating the PHP 1.5 billion Dividend Income from the power segment, the coal segment's Other Income this year, increased by 78% at PHP187.63 million from PHP99.91 million last year, included gain on sale of retired assets, sale of electricity and insurance claims. Meanwhile, the power segment's Other Income of PHP131.26 million this year is mainly composed of sale of fly ash.

The resulting consolidated Income Before Tax stood at PHP6.40 billion, with the coal and power segments contributing PHP3.10 billion and PHP3.30 billion, respectively; meanwhile SLPGC registered a loss of 3.56 million. This year's consolidated Income Before Tax posted a 6% growth over last year's PHP6.01 billion.

Both operating business units enjoy Income Tax Holidays (ITH) as Board of Investments (BOI)-registered companies. Moreover, on 20 September 2012, the coal segment received the approval of its BOI registration for Bobog Mine, another mine site to be developed next to the current active Panian mine. The ITH benefit will start upon commercial operation of the new mine. SLPGC's application for BOI registration was also approved during the year. With these tax holidays, consolidated Provision for Income Tax remained minimal at PHP39.45 million this year. In 2011, consolidated Benefit from Income

Tax posted at PHP22.17 million. The coal and power segments' tax provision this year stood at PHP1.3 million and PHP28.0 million, respectively.

The resulting consolidated Net Income After Tax posted a 5% growth at PHP6.36 billion from PHP6.031 billion last year. Coal and power segments respectively generated PHP3.10 billion and PHP3.28 billion this year, while SLPGC recorded a net loss of PHP8.0 million. Earnings per Share (EPS) correspondingly increased by 5% at PHP17.85 from PHP16.93 last year.

POWER

Another growth area of the power segment is under DMCI Power Corporation, a wholly-owned subsidiary. The Company and its subsidiaries are focused on getting power supply contracts with the National Power Corporation-Small Power Utilities Group. It has power generating units in the provinces of Masbate (24.4 MW diesel power plant) and Palawan (5 x 1.25MW diesel power plant). Masbate started power generation in late 2010 while Palawan just started in December 2012. With a surge in off take demand within a few years of operations brought about by increase in number of connections and development in these areas, the Company is now expanding its current generation capacity. An addition of 21MW diesel generator sets in Palawan by 2013. Moving forward, this segment is looking to replicate this success in other islands and provinces across the country. These developments, anchored on DMCI's engineering expertise, prove to be a testament to its pursuit of growth opportunities. In 2012, generated power sales amounted at P947 million, 17% higher compared to P809 million in 2011.

Nickel

DMCI Mining, Corp., the Company's nickel and metals (non-coal) mining company, continued to mine and sell nickel ore (1.5% and up nickel content) from existing stockpile in Benguet and Acoje mines in Zambales.

Against a weak global nickel ore price caused DMCI Mining's margins to decline. This resulted to net income of P341 million, which was 63% lower than previous year's net income of P917 million. Nickel ore shipments for the year decreased by 7% to 1.6 million wet metric tons (WMT) from last year's 1.7 million WMT. The year-on-year ore shipments from Benguet mines were reported at 836 thousand WMT in 2012 compared to 1,519 thousand WMT in 2011. While the Acoje mine year-on-year shipments stands at 745 thousand WMT in 2012 compared to 181 thousand WMT in 2011. Shipments from the Benguet and Acoje mine are from stockpiles previously mined. Nickel grade shipments were more on the low grade ore causing much of the drop in nickel prices which affected revenues, dropping 22% from last year's P2.45 billion to this year's P1.92 billion. With the end of mining contract for Benguet in 2012 and the Acoje-ENK Mine having some transitory and permitting issues, DMCI Mining is looking at other opportunities for mine acquisition to enhance the segment's operations.

Acquisitions

Following the Group's earlier pronouncement to expand its nickel mining operations, in November 2012 the Parent Company has acquired 60% of the outstanding shares of ENK PLC for P2.1 billion. ENK has major beneficial ownership in the Acoje mine previously being operated by DMCI Mining. However, although the Parent Company acquired 60% of ENK Plc shares, this does not translate to control but to an economic interest. Consequently, as the Parent Company is able to exercise significant influence, it should be accounted as an investment in an associate.

On October 22, 2012, the Company signed a memorandum of understanding (MOU) to purchase from Toledo Mining Corporation PLC (TMC) a 31% stake in Nickeline Resources Holdings, Inc. (NRHI). Under the terms of the MOU, the Company will pay nearly US\$6.5 million in cash for the interest in NRHI.

Also, in October 2012, DMCI Mining acquired a 17% stake of Daintree Resources Limited in TMC for GBP 3.4 million. On February 15, 2013, DMCI Mining increased its stake to 37.7% with the acquisition of an additional 20.7% for GBP 5.2 million. As a result, DMCI Mining launched a mandatory cash offer to acquire the entire issued and to be issued share capital of Toledo not already owned by DMCI Group. The offer will comprise 50 pence in cash for each Toledo share, valuing the whole of Toledo's existing issued share capital at approximately GBP 24.9 million.

As the Philippine Government is also looking to revamp and improve revenue generation and policy implementation in the mining industry, the Company sees opportunities to possibly acquire more mining assets for the Group.

Cost of sales and Services

Mixed pointers for consolidated cost of sales and services, as construction and real estate costs grew while mining and power cost of sales dropped. Overall, consolidated amount increased by 10% mainly due to higher cost of construction materials and labor.

Operating Expenses

Consolidated operating expenses increased by 13% as lower cost of sales increased government royalties at the coal business and the growth in activity and operations of the power business.

Equity in Net Earnings

Equity in net earnings reached P2.3 billion in 2012, 6% higher than last year. The rise was mainly due to higher equity income from the unconsolidated water investment which improved its operations from last year.

Finance Income and Finance Costs

Consolidated net interest expense was higher by P185 million due mainly to new loan availments from the power business to finance expansion, lower interest income from real estate receivables and lower cash balance resulting to a decrease in interest earned from short-term placements.

Other Income

Consolidated other income reached P786 million, 182% higher than last year. The increase was mainly due to higher rental income and foreign exchange gain. It was tempered by the cost of write-down of property, plant and equipment due to the replacements of generation units amounting to P341 million.

Provision for Income Tax

10% increase from P1.3 billion to P1.5 billion mainly caused by higher taxable income of the real estate business.

II. FINANCIAL CONDITION

December 31, 2012 – December 31, 2011

The Company's financial condition for the period improved as consolidated total assets and total net assets amounted to P95.25 billion and P47.99 billion as of December 31, 2012, posting an increase of 13.5% and 18.6%, respectively.

Consolidated cash decreased by 35% from P15.1 billion in December 31, 2011 vs. P9.7 billion in December 31, 2012 due mainly to investment acquisitions and capital expenditures. Moreover, the Parent Company and its subsidiary Semirara paid higher cash dividends in 2012.

Total available-for-sale financial assets (current and non-current) went down by 61% from P224 million to P88 million due to disposal of unquoted equity investments.

Costs and estimated earnings in excess of billings on uncompleted contracts decreased by 73% from P452 million to P123 million mainly caused by pertinent construction contracts with more billings in 2012 but cost incurred and realized profits were largely recognized in the past years.

Total receivables (current and non-current) went up by 51% due mainly to normal trade in the businesses mostly coming from the milestone billings from the construction segment and recognized receivable from newly completed project from real estate segment.

Consolidated inventories grew by 23% coming mainly from the continuing work in progress at the real estate segment.

Other current assets increased by 20% mainly due to payment for advances to suppliers, brokers, contractors and mine rights owners.

Investments were up 32% as a result of the Company's share in net operations of the water business and new equity investments of the group particularly ENK Plc.

Property plant & equipment grew 10% as a result of the rehabilitation costs incurred in the Calaca power units.

Investment properties increased by 94% from P142 million to P276 million mainly due to additional land and improvements held for lease and capital appreciation.

Other noncurrent assets grew by 37% mainly due to third-party deposits e.g. rental deposit, and increased in deferred input vat.

Accounts & other payables increased by 3% mostly as a result of normal trade operations and accruals especially progress billings from subcontractors.

Customers' deposits increased by 45% with the payments received from real estate customers the revenue of which has yet to be realized.

Billings in excess of costs and estimated earnings on uncompleted contracts decreased by 53% from P751 million to P355 million largely caused by pertinent construction contracts with more billings in the past years but cost incurred and realized profits recognized mainly in 2012.

Liabilities for purchased land increased by 23% mainly due to acquisition of certain land properties which are payable over a period of three to four years.

Short-term debt decreased by 58% due to lower acceptances and trust receipts payable which are used by the Group to facilitate payment for importations of materials, fixed assets and other assets.

Income tax payable decreased by 35% from P138 million to P89 million due to higher income tax payments during 2012.

Payable to related parties decreased by 80% from P301 million to P61 million mainly caused by the settlement of advances from the water consortium.

Long-term debt grew by 15% due to receivable discounting and receipt of the first tranche of the corporate note issuance at the real estate segment. Offset by regular debt payments being made mostly at the real estate, coal and power sectors.

Deferred tax liabilities decreased by 19% due to realization of reconciling items particularly excess of book over tax income pertaining to construction contracts and real estate sales.

Pension liabilities increased by 13% from P180 million to P204 million as a result of actuarial valuation particularly the movement in unrecognized net actuarial gain.

Other noncurrent liabilities decreased by 12% due to payment of subscription payable to DMWC.

Retained earnings grew by 26% primarily due to the increase in net income.

Non-controlling interest increased by 13% as a result of the non-controlling interests' share in the consolidated net income of Semirara, net of its share in the dividends declared during the period.

III. KEY PERFORMANCE INDICATORS

The Company and its Subsidiaries (the "Group") has the following as its key performance indicators:

- f) Segment Revenues
- g) Segment Net Income (after non-controlling interests)
- h) Earnings Per Share
- i) Current Ratio
- j) Debt to Equity Ratio

SEGMENT REVENUES

<i>(in Php Millions)</i>	Audited		Variance	
	2012	2011	Amount	%
COAL SALES	P14,450	P16,231	(P1,781)	-11%
NICKEL ORE SALES	1,923	2,452	(529)	-22%
CONSTRUCTION	14,773	10,277	4,496	44%
REAL ESTATE	9,219	8,251	968	12%
ELECTRICITY	11,080	10,421	659	6%
PARENT & OTHERS	294	171	123	72%
TOTAL	51,739	47,803	3,936	8%

The initial indicator of the Company's gross business results are seen in the movements in the different business segment revenues. As illustrated above the significant main drivers for revenue growth are the power, real estate and construction businesses (see *Part I. Results of Operations – different segments for a detailed discussion per business*).

SEGMENT NET INCOME

NET INCOME AFTER NON-CONTROLLING INTERESTS

<i>(in Php Millions)</i>	Audited		Variance	
	2012	2011	Amount	%
COAL SALES	P1,739	P2,379	(P640)	-27%
NICKEL ORE SALES	341	917	(576)	-63%
CONSTRUCTION	1,220	1,117	103	9%
REAL ESTATE	2,182	1,795	387	22%
ELECTRICITY	1,902	1,177	725	62%
WATER	2,264	2,195	69	3%
PARENT & OTHERS	144	15	129	860%
TOTAL	9,792	9,595	197	2%

The net income (after minority) or bottom line results from operations of the Company can be seen with the increment in net income for the period compared to the same period of the previous year/s for the different business segments. Except for the mining segments, the current period posted strong growth in earnings from the power, real estate and construction businesses, while the water segment provided modest improvement (*see Part I. Results of Operations – different segments for a detailed discussion per business*).

EARNINGS PER SHARE

The Company's consolidated earnings per share (EPS) for the year was P3.69/share accounting for a 2% increase from the P3.61/share EPS last year. Same as segment net income, all the businesses except the mining segments contributed to the improvement in earnings (*see Part I. Results of Operations – different segments for a detailed discussion per business*).

CURRENT RATIO

Liquidity is an essential character of any organization, and the Company, including the Group as a whole, should indicate acceptable levels of liquidity. The initial test of liquidity is the current ratio, which will display a company's ability to satisfy current obligations with current resources. Current ratio is arrived by dividing the current assets over the current liabilities. The Company uses this test and compares it with industry balances to determine its ability to satisfy current obligations with respect to its competitors (*see Part II. Financial Condition for a detailed discussion*).

DEBT TO EQUITY RATIO

As a stockholder/investor, financial position and stability would be an important aspect. The Company tests its financial position through the debt to equity ratio. This test indicates the Company's ownership of creditors vs. owners/investors. In addition, debt to equity ratio maintenance is a requirement set by creditors as a standard for extending credit. Debt to equity ratio is computed by dividing the total liabilities over total equity (*see Part II. Financial Condition for a detailed discussion*).

OTHER RELEVANT FINANCIAL SOUNDNESS RATIOS

	Dec. 31 2012	Dec. 31 2011
Current Ratio	183%	204%
Debt to Equity Ratio	52%	53%
Interest Coverage Ratio	1,303%	1,234%
Return on Assets Ratio	13%	15%
Return on Equity Ratio	26%	30%
Asset to Equity Ratio	198%	208%
Gross Margin Ratio	33%	34%
Net Profit Margin Ratio	24%	26%

Full Year 2011 vs. 2010

I. RESULTS OF OPERATIONS

DMCI Holdings, Inc. (the "Company") reported an improvement of 22% in its net income (after minority) from P7.9 billion in 2010 to P9.6 billion in 2011. Despite a slide in general construction and the non-inclusion of operating results from the steel fabrication business, significant growth in the coal, nickel and power segments along with the sustained improvement in the real estate and water businesses caused the growth in consolidated bottom line.

Below is a table on the net income contributions of the Company's businesses for 2011 and 2010:

**NET INCOME AFTER
NON-CONTROLLING INTERESTS**

<i>(in Php Millions)</i>	Audited		Variance	
	2011	2010	Amount	%
COAL SALES	2,379	1,462	917	63%
NICKEL ORE SALES	917	564	353	63%
CONSTRUCTION	1,117	1,242	(125)	-10%
REAL ESTATE	1,795	1,286	509	40%
ELECTRICITY	1,177	847	330	39%
WATER	2,195	1,887	308	16%
PARENT & OTHERS	15	(98)	113	-115%
STEEL		677	(677)	-100%
TOTAL	9,595	7,867	1,728	22%

For the year, mining was the main driver of the P1.7 billion increase in the Company's income due to higher coal prices and the improved operations in the nickel business. The real estate and power generation segments also posted significant growth due to healthier housing sales and increased generation capacity coming from the rehabilitated Calaca unit 2. Investments in the water business,

accounting for 23% of total net income, registered modest improvements, testament of the sustained and consistent operations evident in the utilities sector.

Braced

This year also marks the non-inclusion of Atlantic Gulf & Pacific Company of Manila, Inc., the Company's previously owned steel fabrication business which was sold in December 2010 and contributed almost 9% of last year's net income.

WATER

The Company's investment in the water sector is recognized mainly through its equity investment in the consortium company with Metro Pacific Investments Corp. (MPIC) which owns Maynilad Water Services, Inc. (Maynilad). Maynilad handles the water distribution and sewer services for the western portion of Metro Manila and some areas of Cavite. For 2011, water investment contributions reached P2.2 billion, up by a respective 16% from the previous year.

Maynilad operations reported better efficiencies for 2011 vs. 2010. Billed volume increased by 8.3% or 30.91 million cubic meters (MCM) despite a 3.5%, or 27.8 MCM, reduction in supply causing non-revenue water (NRW) improvement to 47.83% from 53.48%. Average effective tariff also increased by 5.7% coming from inflationary and rebasing adjustments but was lower than the approved 7.6% should be increase in tariff for 2011. As a result Maynilad's water service revenues grew by 12.6% from P9.9 billion to P11.2 billion. Billed services further grew by 11% to a record 1,005,350 accounts, breaching the 1 million mark. This, however, didn't contribute proportionally to the increase in revenues as the growth in accounts was mainly from the domestic or residential customers whose rates are subsidized. Meanwhile, cash Opex showed a 10.4% jump due mainly to the following: (a) higher personnel costs from a redundancy program and manpower build up, (b) utilities, and (c) real estate and business taxes. As a result, Maynilad bottom figure reached P5.9 billion in 2011, growing by 22% from the P4.8 billion in 2010.

The Company's net share in the equitized earning from its water investment in Maynilad for the year reported only P2.2 billion due to the adjustments at the consortium company level. The consortium's ownership in Maynilad was also reduced from 94% in 2010 to 92% in 2011 as Maynilad employees exercised their 2% ESOP late in 2010 which were carved out of the consortium's shareholdings.

CONSTRUCTION

The construction business experienced a marginal decrease from its unprecedented growth last year due to the following: (a) completion of big infrastructure projects with no new infra projects awarded, and (b) last year's income includes recognition of change orders from the Shangrila Boracay project where the costs were conservatively booked in the previous years.

Construction revenues from the Skyway Extension project were reduced in 2011 compared to 2010 as the project reached full completion early in the year. The continuing activity from the 168 Residences, the delayed but now fully resumed Raffles Hotel works provided much of the revenues for the period, and the activity from the recently awarded Entertainment City Complex of Surestre Properties in JV with Bloomberry Resorts and Hotels contributed significantly to 2011 construction revenues. This however was not too good for the construction bottom line as building contracts have relatively less margins than the specialized and complicated big infrastructure projects such as the Skyway Extension project. With the activity for the year coming mainly from the building contracts, construction gross margin and net income slightly declined.

Although delayed, we believe the infrastructure development programs of the current Philippine government thru the Public-Private Partnership (PPP) projects will inevitably materialize. As such, the Company, thru DMCI, is very much interested in the construction and engineering of these initiatives.

The Company believes it is well positioned to be both a driver and a beneficiary of the country's infrastructure progress.

In addition, DMCI was recently awarded the construction of the 135 MW Coal Fired Plant of South Luzon Thermal Energy Corp., a JV between Trans Asia Oil and the Ayala Group and the civil works for the expansion of the Group's Calaca power units. Hopefully, these additional power-infrastructure contracts along with others being eyed by DMCI will generate the much needed lift in construction revenues with better margins.

REAL ESTATE

The Company's real estate business is focused purely on residential development. It is led by the Company's wholly owned real estate development subsidiary, DMCI Project Developers, Inc. (PDI). Under the brand name DMCI Homes, PDI currently develops and sells middle income housing units that define best in quality & value for money dwellings in its market segment.

The Company recognizes real estate revenues using the full accrual method where sales are booked when the unit is fully complete and the down payment of 20% is already collected. This method is already in accordance with International Accounting Standards. There was a plan to adopt this in the country in 2008 but was subsequently suspended by the SEC after majority of the real estate companies lobbied against it due to the retroactive adjustments that will be incurred upon adoption. Despite this, the full accrual method has been and is still used by the Company as we believe the adoption is inevitable if the country wants to be at par with global real estate accounting practices.

The housing segment recognized an impressive 40% increase in net contributions from P1.3 billion last year to P1.8 billion this year. Realized housing sales for the year grew by 25% to P8.2 billion with the completion of existing projects: East Raya, Magnolia Place, Mahogany Place 3, Ohana Residences and Rosewood Pointe, the previous sales of which all contributed to improvement in recognized revenues. Also margins improved as prices inched up due to improvements in quality (eg. better and bigger amenities and facilities) as well as costs were at lower than expected levels. During the year, actual project costs from some completed projects accounted for less than estimated costs booked in the previous years causing cost reversals recognized in 2011.

A better representative of current demand would be sales and reservations for the period which experienced an increase of 17% from P14.7 billion in 2010 to P17.2 billion in 2011. Increasing demand for DMCI housing units coming mainly from the new projects: La Verti Residences in Taft, Pasay City; the Redwoods in Fairview, Novaliches; Siena Park in Bicutan Paranaque and Stellar Place in Quezon City pushed marketing sales to new heights. Moreover, increased take up from added phases in existing projects East Raya and Magnolia Place also added to the growth in sales and reservations.

Operating expenses in the real estate segment were higher by 28% due to:

- Increase in selling and marketing activities such as advertising, sales incentives, marketing tools, ads, project launches, etc.
- Increase in employee salaries & wages
- Increase in utilities and real estate taxes

Note that most of the Company's housing units have a selling price below P3.2 million per unit and as such has been registered with the Board of Investments (BOI) as part of their affordable housing investments that provide vat and income tax incentives.

MINING & POWER

Coal Mining & Power (Calaca-Coal)

The Company's coal mining business which owns the major power asset, Calaca are both lodged under the 56%-owned and publicly listed Semirara Mining Corp (SMC). SMC reported an improvement in operations with a net income of around P4.1 billion for coal mining and P1.9 billion for power generation in 2011 compared to P2.6 billion and P1.3 billion respectively in 2010. This was mainly due to higher coal prices and the improved power generating capacity from the completed phase 1 rehabilitation of Calaca unit 2.

Below is SMC's management discussion and analysis of results of operations and financial condition for the year 2011 as lifted from its consolidated financial report with the PSE and SEC:

MANAGEMENT'S DISCUSSION AND ANALYSIS OF FINANCIAL CONDITION AND RESULTS OF OPERATIONS (YEARS 2009-2011)

I. PRODUCTION AND OPERATIONS

COAL

The acquisition and operation of the 2 x 300 MW power plants in Calaca Batangas gave market security to the coal business segment and the Company, as a group, to hold position in the power sector. The imbalance in the power demand and supply of energy in our country drove the Company to expand its power plant capacities in the next three years. The thrust of the mine operations in 2011 was anchored on this business decision.

There were more drilling programs implemented, particularly focusing on the eastern part of the island, which indicated positive results. These extensive drilling activities are being done to ensure that the expansion of power plant capacities will be accordingly supported by sufficient mineable coal reserves. The data gathered from the exploration and confirmatory drilling are going to be submitted to a local competent person for verification for certification by a competent person according to Philippine Mineral Resource Code (PMRC) standards and will ultimately be subjected to certification process in accordance with Joint Ore Reserve Code (JORC) standards.

With almost the same equipment complement, operations achieved a new record high of total material movement of 85.06million bank cubic meters (bcm), registering an 8% growth from 2010 material movement of 78.68 million bcm. At a higher strip ratio this year of 10:13:1 from 9:73:1 in 2010, run-of-mine (ROM) coal posted a more modest growth of 4% at 7.84million metric tons (MTs) from 7.54million MTs last year. Despite a higher percentage of washable coal this year, net total product coal recorded a 2% increase at 7.12 million MTs from 6.95 million MTs in 2010.

The fourth (4th) loading facility was made operational towards the end of the year. The strategic location of the new loading facility cuts coal transfer time. This improved logistic support necessary for the expanded activities in the island and make coal loading rate faster.

Despite the increased production, marketing efforts were restrained by the impact of the economic woes in Europe and US to the Asia Pacific Region. Exports declined due to high coal inventory in China from Europe which were diverted to Asian market and lower coal demand in Thailand due to flooding. Thus, local orders were given priority and export sales slowed down towards the end of the year. As a result, ending inventory stood at 1.0 million MTs more than double the beginning inventory of only 0.49million MTs.

POWER

UNIT 1

In 2011 Unit 1 was limited to 157 MW average load due to thinned boiler tubes and only one Circulating Water Pump (CWP) in service starting 14 April 2011. Also, the unit was under rehabilitation starting 29 August 2011, hence gross generation reduced by 20% from 2010 level of 915 GWh at 727 GWh this year. Capacity factor, availability, and forced outage rates during the year stood at 28%, 54%, and 4%, respectively. The unit was running for a total of 4,704 hours during the year, and it consumed 477,272 MTs Semcoal.

Unit 1 has been operating for 25 years and issues related to safety, reliability, efficiency, upgrade, obsolescence and environmental consequently arose. The rehabilitation of Unit 1 was undertaken to address these issues that caused the inefficient operations of the plant. It was officially shutdown for rehabilitation last August 29, 2011.

UNIT 2

In 2011 Unit 2 was running at 254MW average load due to extended commissioning and high pressure heater leak. Gross generation for 2011 was 1,132 GWh with 43% capacity factor, 60% availability, and 36% forced outage rates. After the rehabilitation works, generation this year is 57% higher than in 2010 as operating hours improved from 4,230 hours in 2010 to 5,234 hours this year.

The unit experienced 2,976 hours forced outage which is 19% higher than 2010 level due to the increase in load which exposed the plant's weak points leading to de-rating and shutdowns. Fine tuning of boiler was done progressively to correct overheating. Meanwhile, the remaining overheated boiler tubes will be replaced by end 2012, to coincide with the scheduled preventive maintenance shutdown of the plant.

The Distributed Control System (DCS) and the dry bottom ash system will also be installed during the aforementioned scheduled preventive maintenance shutdown. Moreover, all other improvements, correction of deficiencies and modifications will be undertaken during this time. The full rehabilitation program of the plant is expected to be completed and by start of 2013.

II. MARKET COAL

Demand for Semirara coal, both from the local and export markets, remained strong in 2011. However, with its new objective of resource maximization for its investments in the power, the Company strategically cut export sales during the year, such that sales of 6.52million MTs was 9% lower than 2010 sales volume of 7.15million MTs.

The cut in sales volume came from export deliveries which dropped by 41% at 2.43million MTs from 4.10million MTs in 2010. Conversely, local sales increased by 34% at 4.09million MTs from 3.05million MTs in 2010.

With increasing local demand, marketing efforts shifted back to prioritizing the domestic market to fully benefit from its competitive advantages over imported coal. Thus, from a 43% : 57% market share in favor of export sales in 2010, the scale has tipped to 63%: 37% in 2011.

Bulk of the local sales were delivered to the power plants, totaling to 3.27million MTs, increasing by 92% from power plant sales of 1.70million MTs in 2010. SCPC's total deliveries increased by 47% at 1.41million MTs this year from 0.96million MTs in 2010 as first phase of Unit 2 rehabilitation was completed this year, thus increasing the plant's effective capacity and utilization rate. Meanwhile, deliveries to other power plants tripled from 0.74million MTs in 2010 to 1.86million MTs this year. The huge increase mainly came from the increase in off-take of a customer with power plants in the Visayas with a long-term supply agreement with the Company. Sales to the power sector accounted for 50% of total sales in 2011.

Sales to local cement plants remained flat at 0.66million MTs in 2011 from 0.66 MTs in 2010. This year, the Company has more direct sales to end-users , unlike in the previous years, wherein most of its sales to cement plants were made via local trader Cement plant's market share inched up slightly at 10% this year from 9% in 2010.

Meanwhile, sales to other industrial plants recorded a significant 77% drop from 0.68 million MTs in 2010 to 0.16million MTs this year. This was caused by lower purchases by a local broker who delivers to small industrial plants. As a result, this industry's market share dropped to 2% from 10% in 2010.

High global coal prices translated to a remarkable 31% increase in composite average price from PHP2,343 in 2010 to PHP3,078 this year. The Company already adopted a coal pricing mechanism which is indexed to global coal prices.

POWER

SCPC's recorded sales for bilateral contracts for 2011 increased by 14% to 1,553 GWh from its recorded sales in 2010 of 1,368 GWh. This is attributed to the renewal of contract with one of its previous customers, the Batangas I Electric Cooperative, Inc. (BATELEC I); a new power supply contract with Trans-Asia Oil and Energy Development Corporation, which took effect in April and March 2011, respectively; and an arrangement with the National Power Corporation (NPC) for a non-firm power supply to MERALCO on top of the existing firm power supply to MERALCO under the existing Contract for the Supply of Electric Energy inherited by SCPC from NPC.

MERALCO remained to be the biggest customer of SCPC accounting for 33% share of the total energy sales for SCPC's bilateral contracts.

SCPC's sales from the spot market, however, dropped by 1%, from 476 GWh in 2010 to 472 GWh in 2011. The decrease in sales to spot market was mainly due to the approval of non-firm nominations of Meralco.

Overall, a total energy of 2,025GWh was sold in 2011, 77% directly to the customers through bilateral contracts, and 23% to the spot market. The total energy sales increased by 10% from 1,845 GWh recorded in 2010.

Of the total energy sold, 85% was sourced from the generation of the power plants, while 15% was purchased from the spot market. SCPC secured replacement power from the spot market to meet its supply obligation to MERALCO.

In December 2011, SCPC inked a new power supply contract with Meralco effective December 26, 2011 for a term of seven (7) years with an option to extend for another three (3) years upon mutual agreement. The initial contracted capacity is 210 MW and will be increased to 420MW upon commercial operation of the other unit after rehabilitation or 210MW for each unit.

III. FINANCE

A. Sales and Profitability

High coal prices and increase in energy sales resulted to a 13% growth in consolidated Revenues in 2011 at PHP25.81 billion from PHP22.90 billion in the previous year. Net of eliminating entries, coal and energy Revenues stood at PHP16.20 billion and PHP9.61 billion, respectively.

Consolidated Cost of Sales increased by 5% at PHP9.15 billion from PHP6.99 billion in 2010.

After eliminating entries, the coal and power segments accounted for Cost of Sales of PHP10.26 billion and PHP6.40 billion, respectively. Cost of Coal Sold/MT increased by 21% from PHP1,770 in 2010 to PHP2,148 this year due to significant increases in rate of fuel consumption per cycle time and fuel, materials and spare parts prices, along with the increase in stripping ratio. On the other hand, the power

segment's Cost of Sales/KW hr registered a slight 1% growth from PHP3.13 in 2010 to PHP3.16 in the current period.

The increase in per unit Cost of Sales was sufficiently covered by the increase in selling prices for both the coal and power segments. Thus, Gross Profit Margin increased from 31% in 2010 to 35% in the current period. As a result, consolidated Gross Profit registered a healthier growth of 31% from PHP6.99 billion in 2010 to PHP9.15 billion this year.

Meanwhile, consolidated Operating Expenses increased by 6% from PHP2.72 billion in 2010 to PHP2.88 billion this year. The coal segment's Operating Expenses of PHP1.86 billion is mainly composed of Government Share of PHP1.48 billion. On the other hand, the power segment incurred PHP999.00 million in Operating Expenses, which comprised mainly of the O&M fee of the plant. In addition, the Company invested in two new companies during the year. One is the Southwest Luzon Power Generating Corp. (SLPGC) which will undertake the expansion of the power capacities with the construction of 2 x 150 MW plants adjacent to the existing power plants of SCPC. Pre-operating expenses of PHP20.23 million were incurred during the year. Another Company was incorporated, the Sem-Cal Industrial Park Developers, Inc. (SIPDI) which aims to develop the Calaca property into an economic zone. In 2011, it incurred Pre-operating Expenses of PHP50 thousand.

Consolidated Financing Cost dropped by 28% from PHP668.44 million in 2010 to PHP483.29 million this year. The decrease was due to the decline in the balance of the SCPC loan, which partly financed the acquisition of the asset, from PHP9.6 billion in 2010 to PHP8.6 as at the end of 2011. Augmented by the drop in interest rates, Financing Cost of the power sector decreased by 19% from PHP490.63 in 2010 to PHP396.78 million this year. Meanwhile, although total loans of the coal segment increased in 2011, due to the decrease in interest rates, its Financing Costs in 2011 of PHP86.51 million decreased by 56% from 2010 level of PHP177.81 million, mainly from dollar denominated loans.

On the contrary, consolidated Finance Income rose by 134% from PHP57.67 million to PHP134.88 million. Short-term placement rates improved in 2011 compared to 2010. Moreover, all business units had healthier cash positions during the year. The coal segment's Finance Income increased by 165% at PHP79.45 million from PHP30.02 in 2010; while the power segment generated PHP55.43 million this year, posting a 100% increase from last year's level of PHP27.65 million. Meanwhile, SLPGC recognized Finance Income of PHP10.54 from its partially paid-up capital placed in short-term time deposit accounts.

Meanwhile, foreign exchange fluctuations resulted to consolidated Forex Losses of PHP38.32 million, the coal and power segments incurred Forex Losses of PHP26.01 million and PHP12.31 million, respectively. In 2010, the fluctuations moved in favor of the Company, thus enabling it to recognize consolidated Forex Gains of PHP 199.49 million.

Consolidated Other Income of PHP99.91 was generated by the coal segment mainly from sale of retired mining equipment and proceeds from insurance claims of PHP53.55 million and 35.12 million respectively. This posted a 53% growth from 2010 level of PHP65.43 million.

Consolidated Net Income Before Tax showed an impressive growth of 53% at PHP6.01 billion from PHP3.95 billion last year. Minimal losses from the two pre-operating companies were sufficiently covered by the healthy income generation of the coal and power segments, which stood at PHP4.14 billion and PHP1.87 billion, respectively, net of eliminating entries. Meanwhile, both business segments have Income Tax Holidays as Board of Investments registered companies (as expanding coal producer and as power generator). As a result, consolidated Tax Provision amounted to negative provision of PHP22.17 million consisting of final income taxes amounting to PHP22.76, net of deferred income taxes of PHP44.93 million.

The resulting consolidated Net Income After Tax closed at PHP6.03 billion, the coal and power segments respectively contributed PHP4.17 billion and PHP1.87 billion. Net earnings this year posted a remarkable 51% growth from consolidated Net Income After Tax in 2010 of PHP3.95 billion. Earnings per Share

increased by 40% from PHP12.10 last year to PHP16.93 this year, after the number of outstanding shares increased mid-2010 due to a stock rights offering exercise.

Nickel

DMCI Mining, Corp., the Company's nickel and metals (non-coal) mining company, continued to mine and sell high concentration nickel ore (1.8%-2% nickel content) from the Benguet mine in Zambales. DMCI Mining has also started operating at the old Acoje mine via a contract with Zambales Diversified Mining Corp., an affiliate of European Nickel (a London and Australia listed mining company that merged and acquired Rusina Mining). First shipment from this mine has been subsequently made in the 2nd half of 2011. The reinstated operations in Acoje was envisioned to supplement and maybe replace production from Benguet since the current contract with Benguet is expected to be finished by 2012.

DMCI Mining reported continuous growth in 2011 as net contributions after eliminations reached P917 million compared to P564 million in 2010. Nickel ore shipments for the year, came mainly from the Benguet mine (minimal from Acoje), which achieved a record 1.7 million wet metric tons (WMT) this year compared to 1.2 million WMT last year. Despite a drop in average selling price, revenues still grew by 25% due to the growth in sales volume. Moreover, improved mining operations resulted to better gross margins, testament to the DMCI engineering pedigree.

With the current direction of Benguet to operate on its own and the Acoje mining operations with European Nickel looking to follow suit, the Company is now exploring acquiring its own nickel and other metal resource assets. As the Philippine Government is also looking to revamp and improve revenue generation and policy implementation in the mining industry, the Company sees a few opportunities to possibly acquire mining assets for the group. If these initiatives are successful the Company hopes that the nickel mining business will grow significantly to be a major contributor to consolidated operations.

Cost of sales and Services

Except for Construction business which account for 27% of 2011 cost of sales, all the other businesses reported an increase in cost of sales due to growth in the operations of their respective areas.

Operating Expenses

The 9% increase is primarily from the jump in government royalties at the coal business, the heightened marketing and selling activities in the real estate sector, the growth in activity and operations of the power business.

Equity in Net Earnings

Equity in net earnings reached P2.2 billion in 2011, 15% higher than last year. The rise was mainly due to higher equity income from the unconsolidated water investment which improved its operations from last year.

Finance Income and Finance Costs

Consolidated net interest expense was lower at P164 million in 2011 compared to P519 million in 2010 due mainly to the reduced debt from the acquisition of the Calaca Power Plant and increased in interest income from short-term placements as a result of higher placement value.

Other Income

Consolidated other income was slightly lower by 11% mainly due to foreign exchange loss and lower rental income.

Provision for Income Tax

31% increase from P1.0 billion to P1.3 billion mainly caused by higher taxable income and deferred tax effect on installment sales of the real estate segment.

II. FINANCIAL CONDITION

December 31, 2011 – December 31, 2010

The Company's financial condition for the period improved as total assets and net assets increased by 18% and 25% respectively.

Cash increased by a significant 51% to P15 billion due mainly from operations of the different business and the syndicated loan raised by the real estate business. Major generator of cash is from operations while the major use of cash is for PPE.

Total receivables (current and non-current) went up due mainly to new sales in all sectors and the reinstatement of owner/supplier receivables covered with owner/supplier advances at the construction business.

Consolidated inventories grew by 28% increase as ending inventories grew in the real estate, power and coal mining businesses. Real estate inventories grew due to the growth in completed and in progress units including new land acquired for development. Inventories for power equipment and ending coal inventories prompted the increase in Semirara's consolidated inventory.

Investments were slightly up as a result of the Company's share in net operations of the water business and other equity investments of the group.

Property plant & equipment inched up coming mainly from the rehabilitation of Calaca unit 2.

Accounts & other payables increased mostly as a result of using operating credits, deferred revenues and accruals.

Long term debt increased due to the P5 billion corporate notes issued at the real estate segment.

Current ratio improved from 1.78 to 2.04 due mainly from cash generation of the different businesses.

Debt to equity ratio remained at the same levels despite additional debt issued at the real estate business as operations generated the much needed net asset growth.

III. KEY PERFORMANCE INDICATORS

The Company and its Subsidiaries (the "Group") has the following as its key performance indicators:

- k) Segment Revenues
- l) Segment Net Income (after Non-controlling Interest)
- m) Earnings Per Share
- n) Current Ratio
- o) Debt to Equity Ratio

SEGMENT REVENUES

REVENUES		
<i>(in Php Millions)</i>	Audited	Variance

	2011	2010	Amount	%
COAL SALES	16,231	14,071	2,160	12%
NICKEL ORE SALES	2,452	1,959	493	25%
CONSTRUCTION	10,277	10,729	-452	-4%
REAL ESTATE	8,251	7,705	546	7%
ELECTRICITY	10,421	8,948	1,473	16%
PARENT & OTHERS	171	72	99	137%
TOTAL	47,803	43,484	4,319	10%

The initial indicator of the Company's gross business results are seen in the movements in the different business segment revenues. As illustrated above the significant main drivers for revenue growth are the mining and real estate sectors (see *Part I. Results of Operations – different segments for a detailed discussion per business*).

SEGMENT NET INCOME

NET INCOME AFTER NON-CONTROLLING INTERESTS

<i>(in Php Millions)</i>	Audited		Variance	
	2011	2010	Amount	%
COAL SALES	2,379	1,462	917	63%
NICKEL ORE SALES	917	564	353	63%
CONSTRUCTION	1,117	1,242	(125)	-10%
REAL ESTATE	1,795	1,286	509	40%
ELECTRICITY	1,177	847	330	39%
WATER	2,195	1,887	308	16%
PARENT & OTHERS	15	(98)	113	-115%
STEEL		677	(677)	-100%
TOTAL	9,595	7,867	1,728	22%

The net income (after minority) or bottom line results from operations of the Company can be seen with the increment in net income for the period compared to the same period of the previous year/s for the different business segments. Except for construction, the current period posted strong growth in earnings from the coal and nickel mining businesses, while other segments provided modest improvement (see *Part I. Results of Operations – different segments for a detailed discussion per business*).

EARNINGS PER SHARE

The Company's consolidated earnings per share (EPS) for the year was P3.61/share accounting for a 22% increase from the P2.96/share EPS last year. Same as segment net income, all the businesses except construction all contributed to the improvement in earnings (see *Part I. Results of Operations – different segments for a detailed discussion per business*).

CURRENT RATIO

Liquidity is an essential character of any organization, and the Company, including the Group as a whole, should indicate acceptable levels of liquidity. The initial test of liquidity is the current ratio, which will display a company's ability to satisfy current obligations with current resources. Current ratio is arrived by dividing the current assets over the current liabilities. The Company uses this test and compares it with industry balances to determine its ability to satisfy current obligations with respect to its competitors (see *Part II. Financial Condition for a detailed discussion*).

DEBT TO EQUITY RATIO

As a stockholder/investor, financial position and stability would be an important aspect. The Company tests its financial position through the debt to equity ratio. This test indicates the Company's ownership of creditors vs. owners/investors. In addition, debt to equity ratio maintenance is a requirement set by creditors as a standard for extending credit. Debt to equity ratio is computed by dividing the total liabilities over total equity (see *Part II. Financial Condition for a detailed discussion*).

OTHER RELEVANT FINANCIAL SOUNDNESS RATIOS

	<u>Dec. 31</u> <u>2011</u>	<u>Dec. 31</u> <u>2010</u>
-		
- <u>Current Ratio</u>	- <u>204%</u>	- <u>179%</u>
<u>Debt to Equity Ratio</u>	<u>53%</u>	<u>59%</u>
<u>Interest Coverage Ratio</u>	<u>1,234%</u>	<u>694%</u>
<u>Return on Assets Ratio</u>	<u>15%</u>	<u>14%</u>
<u>Return on Equity Ratio</u>	<u>30%</u>	<u>30%</u>
<u>Asset to Equity Ratio</u>	<u>208%</u>	<u>220%</u>
<u>Gross Margin Ratio</u>	<u>34%</u>	<u>30%</u>
<u>Net Profit Margin Ratio</u>	<u>26%</u>	<u>22%</u>

II. OTHER INFORMATION

10. The company's operation is a continuous process. It is not dependent on any cycle or season;
11. Economic and infrastructure developments in the country may affect construction business; Interest rate movements may affect the performance of the real estate industry; Mining activities are generally hinge on the commodities market. Businesses not affected by known cycle, trends or uncertainties are power and water.
12. A cash dividend was declared at the amount of Php 1.20 per common share paid on July 5, 2012 to the holders of record of June 15, 2012. On April 11, 2013, the BOD of the Parent Company has declared cash dividends amounting Php 1.20 regular dividends and Php1.00 special cash dividends in favor of the stockholders of record as of April 26, 2013. This is due to be paid on May 10, 2013 with the total amount of P5,842.09 million.
13. There were no undisclosed material subsequent events that have not been disclosed for the period that the company have knowledge of;
14. There are no material contingencies during the year; any event that may trigger direct or contingent financial obligation that is material to the company, including any default or acceleration of an obligation has been disclosed in the notes to financial statements.

15. There are no material off-balance sheet transactions, arrangements, obligations (including contingent obligations), and other relationships of the company with unconsolidated entities or other persons created during the reporting period
16. Except for interest payments on loans, which the Company can fully service, the only commitment that would have a material impact on liquidity are construction guarantees. These are usually required from contractors in case of any damage / destruction to a completed project.
17. Any known trends or any known demands, commitments, events or uncertainties that will result in or that will have a material impact on the registrant's liquidity. - **None**
18. The Group does not have any offering of rights, granting of stock options and corresponding plans therefore
19. No transferring of assets except in the normal course of business was done during the relevant interim period
20. No transferring of assets except in the normal course of business was done during the relevant interim period

III. FINANCIAL STATEMENTS

The Financial Statements incorporated herein by reference to the attached audited financial statements.

D. INFORMATION ON INDEPENDENT ACCOUNTANT AND OTHER RELATED MATTERS

The principal accountants and external auditors of the Company and its subsidiaries is the accounting firm Sycip, Gorres, Velayo and Co. (SGV & Co.). Pursuant to the General Requirements of SRC Rule 68, paragraph 3 (Qualifications and Reports of Independent Auditors), the Company and its subsidiaries has engaged the services of SGV & Co. as external auditor and Mr. Michael C. Sabado is the Partner-in-Charge starting 2012 audit period or less than five years following the regulatory policy of audit partner rotation every five years.

I. External Audit Fees and Services

- a. **Audit and Audit Related Fees – The Company and its Subsidiaries paid its external auditors the following fees in the past two (2) years:**

	2012	2012
	Fee	Fee
Semirara Mining Corporation	2,217,600.00	2,032,800.00
Sem-Calaca Power Corporation	1,848,000.00	1,601,600.00
Sem-Cal Industrial Park Developers, Inc.	36,960.00	36,960.00
South Luzon Power Corporation	308,000.00	49,280.00
DMCI Holdings, Inc.	2,975,280.00	2,833,600.00
D. M. Consunji, Inc.	1,312,500.00	1,250,000.00
DMCI Project Developers Inc.	2,610,115.20	2,439,360.00
DMCI Homes Inc.	449,519.84	420,112.00
Hampstead Gardens Corporation	348,015.36	325,248.00
PDI Hotels, Inc.	159,507.04	149,072.00
DMCI Masbate Power Corporation	351,120.00	338,800.00

DMCI Mining Corporation	338,800.00	308,000.00
DMCI Power Corporation	239,008.00	338,800.00
DMCI Homes Property Management Corporation	-	73,920.00
Beta Electric Corporation	420,420.00	400,037.95
Wirerope Corporation of the Philippines	468,160.00	431,200.00
Semirara Claystone Inc.	49,280.00	-
Sem Calaca RES Corporation	36,960.00	-
Semirara Energy Utilities , Inc.	30,800.00	-
Sem Balaya Power Generation Corp.	30,800.00	-
St. Raphael Power Power Generation Corp.	30,800.00	-
DMCI Palawan Power Corporation	24,640.00	-
Grand Total	14,286,285.44	13,028,789.95

- b. Tax Fees - **NONE**
- c. All other fees – **NONE**
- d. Changes In And Disagreements With Accountants On Accounting And Financial Disclosure - **There has been no change or disagreements with certifying accountants.**
- e. The Company's Audit Committee reviews and discusses with management and the external auditor the annual audited financial statements, including discussion of material transactions with related parties, accounting policies, as well as the external auditor's written communications to the Committee and to management. It also reviews the external auditor's audit plans that increase the credibility and objectivity of the Company's financial reports and public disclosure.

PART IV - MANAGEMENT AND CERTAIN SECURITY HOLDERS

A. Directors and Executive Officers of the Issuer

(1) Identify Directors, Including Independent Directors, and Executive Officer.

<u>Name</u>	<u>Position</u>	<u>Age</u>
DAVID M. CONSUNJI	Chairman of the Board of Directors	92
CESAR A. BUENAVENTURA	Vice-Chairman of the Board	84
ISIDRO A. CONSUNJI	President	65
CRISTINA C. GOTIANUN	Asst. Treasurer	59
HERBERT M. CONSUNJI	Director/Vice President & CFO	61
JORGE A. CONSUNJI	Director	62
VICTOR A. CONSUNJI	Director	63
MA. EDWINA C. LAPERAL	Director	52
HONORIO O. REYES-LAO	Director (Independent)	69
ANTONIO JOSE U. PERIQUET	Director (Independent)	53
NOEL A. LAMAN	Corporate Secretary	74
VICTOR S. LIMLINGAN	Managing Director	69

David M. Consunji is the Founder and Chairman of the Board of Directors of D.M. Consunji, Inc. Mr. Consunji is also Chairman of Dacon Corporation, and Semirara Mining Corporation. Mr. Consunji served as the Secretary of the Department of Public Works, Transportation and Communications from August 1971 to 1975. Awards and recognition received by Mr. Consunji include (i) named Meralco Awardee in Engineering and Applied Sciences, 1994; (ii) recipient of the Civil Engineer Diamond Jubilee Award presented by the University of the Philippines Alumni Engineers in 1985; (iii) One of the Ten Outstanding Civil Engineers in 1982 by the Philippine Institute of Civil Engineers; (iv) recipient of Doctor of Laws, honoris causa, University of the Philippines in 1993; (v) named Outstanding Citizen of the City of Manila for Engineering in 1979; and (vi) named Management Association of the Philippines Awardee in 1996, Outstanding Alumni Engineer of the University of Phils. Alumni Engineers in 2010, and Icon of the Philippine Construction Industry 2010 by the Phil. Constructors Association. Mr. David Consunji has served the Corporation as Chairman of the Board for nineteen (19) years since March 1995.

Cesar A. Buenaventura, is Chairman of Buenaventura Echaz and Partners, Inc. He is currently a Director of the following: DMCI Holdings, Inc., Semirara Mining Corporation, iPeople Inc., D.M. Consunji, Inc., Petroenergy Resources Corp., AG&P Company of Manila, Inc., Montecito Properties, Inc. (Vice Chairman), Pilipinas Shell Petroleum Corp., Philippine American Life Insurance Company and Manila International Airport Authority. He was chosen Management Man of the Year in 1985 by MAP and in January 1991, he was personally granted the award of Honorary Officer of the Order of the British Empire by her Majesty Queen Elizabeth II. Mr. Buenaventura has served the Company as Vice Chairman for nineteen (19) years since March 1995.

Isidro A. Consunji is a regular Director of the following: DMCI Project Developers, Inc., Semirara Mining Corporation, Dacon Corporation, DMCI-MPIC Water Company, Inc. Crown Equities, Inc. and Beta Electric Corporation. His other positions include: Chairman of the Board of Directors of DMCI Homes, Beta Electric Corporation; President of Dacon Corporation, DMCI Project Developers, Inc. and Sem-Calaca Power Corp. Mr. Isidro Consunji has served the Corporation as a regular director for nineteen (19) years since March 1995.

Herbert M. Consunji is a Partner in H.F. Consunji & Associates. He is also the Chairman of Subic Water and Sewerage Company, Inc., a regular Director of DMCI Project Developers, Inc., Semirara Mining Corporation, DMCI-MPIC Water Company, Inc., Maynilad Water Services, Inc., DMCI Mining Corp., DMCI Power Corporation and the Chief Operating Officer of Maynilad Water Services, Inc. Mr. Herbert Consunji has served the Corporation as a regular director for nineteen (19) years since March 1995.

Jorge A. Consunji is the President and Chief Operating Officer of D.M. Consunji, Inc. His other positions include: Director of Semirara Mining Corporation, Beta Electric Corp., Atlantic, Gulf & Pacific Company of Manila, Inc., Chairman of Wire Rope Corporation, and Treasurer of Dacon Corporation. Mr. Jorge Consunji has served the Corporation as a regular director for nineteen (19) years since March 1995.

Victor A. Consunji is a Director of the following: DMCI Holdings, Inc., Dacon Corporation (Vice-President), Semirara Mining Corporation (President), One Network Bank (Chairman), M&S Company, Inc., Sodaco Agricultural Corporation, Sirawai Plywood & Lumber Corp. (Chairman), DMC Urban Property Developers, Inc., DM Consunji, Inc., and Ecoland Properties Development Corporation. Mr. Victor Consunji has served as a regular director of the Corporation for nineteen (19) years since March 1995.

Ma. Edwina C. Laperal is the Treasurer of DMCI Holdings, Inc., Dacon Corporation, DMCI Project Developers, Inc., and DMCI Urban Property Developers, Inc.; Regular Director of DMCI Holdings, Inc., DMCI Project Developers, Inc., Semirara Mining Corporation and D.M. Consunji, Inc. Ms. Laperal has served the Corporation as Treasurer for nineteen (19) years since March 1995.

Honorio O. Reyes-Lao is the Director of Philippine Business Bank from 2010 up to present. He was the President and Director of Gold Venture Lease and Management Services, Inc, 2008-2009; Senior Business Consultant of the Antel Group of Companies, 2007-2009; Senior Management Consultant of East West Banking Corporation, 2005-2006. Prior to 2005, Mr. Reyes-Lao was the Senior Vice-President of China Banking Corporation in charge of the lending operation under the Account Management Group. He was a Director of the First Sovereign Asset Management Corporation, 2004-'06; Director and Treasurer of CBC Insurance Brokers, Inc, 1998- 2003 : Director of CBC Forex Corporation, 1997-2002; and CBC Properties and Computer Center, Inc, 1993-2006. His civic affiliations are the Makati Chamber of Commerce and Industries - past President; Rotary Club of Makati West – Treasurer; and a Fellow in the Institute of Corporate Directors, a professional organization which espouses good corporate governance in both private and public organizations. Mr. Reyes-Lao has served the Company as Independent Director for five (5) years (since July 2009).

Antonio Jose U. Periquet is currently the Chairman of Pacific Main Holdings; Director of the Lyceum of the Philippines University, The Straits Wine Company, Inc., Ayala Corporation, BPI Capital Corporation, Bank of the Philippine Islands, BPI Family Bank, Campden Hill Group, Regis Financial Advisers, Inc., ABS-CBN Corporation, Philippine Seven Corporation and Pancake House, Inc. He was previously chairman of Deutsche Regis Partners, Inc. and executive director of various financial institutions in London and Hong Kong. Mr. Periquet holds an MBA from the University of Virginia, a MSc in Development Economics from Oxford University and a Bachelor of Arts degree in Economics from the Ateneo de Manila University. He is a member of the Dean's Global Advisory Council, Darden School of Business, University of Virginia. Mr. Periquet has served the company as an Independent Director for four (4) years since July 2010.

Victor S. Limlingan is Managing Director of DMCI Holdings, Incorporated as well as a Director of D. M. Consunji, Incorporated and DMCI Project Developers Inc. (DMCI Homes). He is presently an independent director of Sika Philippines, a subsidiary of Sika International of Switzerland and Monarch Insurance, a joint venture company owned by Malaysian and Sri Lankan groups. An educator, he holds a Doctorate in Business Administration from the Harvard Business School. He was a Full Professor at the Asian Institute of Management as well as a member of the Presidential Task Force on Education. Presently, he is the Chairman of the Guagua National Colleges. He and his wife Marita own and manage Regina Capital Development Corporation, a member of the Philippine Stock Exchange as well as Cristina Travel Corporation. Dr. Limlingan has served the Company as Independent Director for three years (from July 2006-January 2009). On February 1, 2009, he was appointed as the Managing Director of the Corporation.

Cristina C. Gotianun is a Director of Dacon Corporation, D.M. Consunji, Inc, Asia Industries, Inc., DMCI Power Corporation, DMC Construction Equipment Resources, Inc., DMC Urban Property Developers, Inc., M&S Company, Inc., Prime Ortigas Development Corporation and South Davao Development Co., Inc.. Her other positions include: Vice-President for Administration of Semirara Mining Corp., Treasurer of DMCI Power Corp., Vice President for Finance Administrative/Chief Finance Officer of D.M. Consunji, Inc., and Corporate Secretary of Dacon Corporation and DMC Urban Property Developers, Inc.. Ms. Gotianun has served the Corporation as Asst. Treasurer for nineteen (19) years since March 1995.

Noel A. Laman is a founder and Senior Partner of Castillo Laman Tan Pantaleon & San Jose. His other positions include: Treasurer of the DCL Group of Companies (Manpower Resources of Asia/Sealanes Marine Services/Center for Multicultural Studies/CRAFT Technologies, Inc.); Director and Corporate Secretary of Boehringer Ingelheim (Phils.), Inc., and Merck, Inc. He is an active member of the Intellectual Property Association of the Philippines, the Philippine Bar Association, and have been a speaker in local and foreign legal seminars and a resource person of various foreign chambers of commerce in the Philippines. Mr. Laman's practice of law includes corporate law, intellectual property and mergers and acquisition. He is the firm's representative to the State Capital Group, a US based

group of international law firms. Atty. Laman has served the Corporation as Corporate Secretary for nineteen (19) years since March 1995.

Currently, there are no director or executive officer share options relating to the capital of the Company.

(2) Identify Significant Employees –

- (a) The following are the significant employees of the Registrant who are not executive officers but who are expected by Registrant to make a significant contribution to the business:

Significant Employees	Position held in Registrant	Age
Ma. Luisa C. Austria	Administrative / Accounting Officer	62
Aldric G. Borlaza	Senior Finance Officer	36
Brian T. Lim	Finance Officer	28

Ms. Ma. Luisa C. Austria, Mr. Aldric G. Borlaza, and Mr. Brian T. Lim will continue to hold their respective positions with the Registrant for the year 2013-2014.

- (b) Brief descriptions of the business experience of the above significant employees of the Registrant:

Ma. Luisa C. Austria is a former Accounting Supervisor of D. M. Consunji, Inc. (1989 to 1996). She is now the Administrative/Accounting Officer of the Registrant and has been holding said position for seventeen (17) years since 1996.

Aldric G. Borlaza worked for three (3) months in SGV, Assurance or External Audit group, involving basic audit of accounting controls, documents and paper trail as well as basic preparation of Audited Financial Statements (January 2002 to March 2002). He is the Finance Officer of the Company from April 2002-2012. He now holds a position of Senior Finance Officer since 2012 to present.

Brian T. Lim is the Finance Officer of the Company since August 15, 2012. He used to work with Sycip, Gorres, Velayo & Co. (SGV) for five years as assurance director/audit manager.

Term of office. The term of office of Ms. Austria is approximately eighteen (18) years. Mr. Borlaza has been serving the company for twelve (12) years since April of 2002. Mr. Lim has been with the Company for one year and eight months.

(3) Family Relationships - Describe any family relationships up to the fourth civil degree either by consanguinity or affinity among directors, executive officers, or persons nominated or chosen by the registrant to become directors or executive officers. – **See below:**

<u>Name</u>	<u>Relationship</u>
David M. Consunji	Father of Isidro A. Consunji, Jorge A. Consunji, Victor A. Consunji, Cristina C. Gotianun and Ma. Edwina C. Laperal

Isidro A. Consunji, Jorge A. Consunji, Victor A. Consunji, Cristina Gotianun, and Ma. Edwina C. Laperal

Children of David M. Consunji

Herbert M. Consunji

Nephew of David M. Consunji and cousin of Isidro A. Consunji, Jorge A. Consunji, Victor A. Consunji, Cristina C. Gotinanun, and Ma. Edwina C. Laperal

(4) Involvement in Certain Legal Proceedings - *None of the directors, executive officers and nominees for election is subject to any pending material legal proceedings*

(a) Any bankruptcy petition filed by or against any business of which such person was a general partner or executive officer either at the time of the bankruptcy or within two years prior to that time - **NONE**

- viii. Any conviction by final judgment, including the nature of the offense, in a criminal proceeding, domestic or foreign, or being subject to a pending criminal proceeding, domestic or foreign, excluding traffic violations and other minor offenses - **NONE**
- ix. Being subject to any order, judgment, or decree, not subsequently reversed, suspended or vacated, of any court of competent jurisdiction, domestic or foreign, permanently or temporarily enjoining, barring, suspending or otherwise limiting his involvement in any type of business, securities, commodities or banking activities - **NONE**
- x. Being found by a domestic or foreign court of competent jurisdiction (in a civil action), the Commission or comparable foreign body, or a domestic or foreign Exchange or other organized trading market or self regulatory organization, to have violated a securities or commodities law or regulation, and the judgment has not been reversed, suspended, or vacated – **NONE**

B. Executive Compensation

ANNUAL COMPENSATION

Name	Principal Position	Salary	Bonus	Per Diem Allowance**	Other annual compensation
David M. Consunji	Chairman of the Board of Directors				
Cesar A. Buenaventura	Vice – Chairman of the Board of Directors				
Isidro A. Consunji	President/Chief Executive Officer				
Herbert M. Consunji	Vice President & Chief Financial Officer				
Ma. Edwina C. Laperal	Treasurer				

	YEARS				
	2011	P 93,701,111.00		P 240,000.00	P 8,532,185.00
	2012	P 68,466,633.46		P 220,000.00	P 9,515,941.20
	2013	P 46,386,287.94		P 200,000.00	P 5,876,764.72
	2014*	P 46,386,287.94		P 200,000.00	P 5,876,764.72
	TOTAL:	P 254,940,320.34		P 860,000.00	P 10,659,075.64
	YEARS				
All other directors and executive officers as a group unnamed	2011	P 60,278,449.08		P 120,000.00	P 2,618,299.00
	2012	P 29,749,137.42		P 170,000.00	P 3,646,176.48
	2013	P 30,770,953.59		P 360,000.00	P 2,135,588.24
	2014*	P 30,770,953.59		P 360,000.00	P 2,135,588.24
	TOTAL:	P 151,569,493.68		P1,010,000.00	P 10,535,651.96

*Approximate figures

** Each director receives Php 10,000.00 for every regular meeting of the Board.

There is no contract covering their employment with the Corporation and they hold office by virtue of their election to office. The Company has no agreements with its named executive officers regarding any bonus, profit sharing, pension or retirement plan.

There are no outstanding warrants, options, or right to repurchase any securities held by the directors or executive officers of the Company.

C. Security Ownership of Certain Beneficial Owners and Management

a. Beneficial Ownership of Directors of the Corporation as of December 31, 2013.

Title of Class	Name of Beneficial Owner	Amount and Nature of Beneficial Ownership	Percent of Class
Common	David M. Consunji	1,000.00	0.0000%
Common	Cesar A. Buenaventura	180,000.00	0.0068%
Common	Isidro A. Consunji	13,000.00	0.0005%
Common	Victor A. Consunji	1,000.00	0.0000%
Common	Jorge A. Consunji	1,000.00	0.0000%
Common	Herbert M. Consunji	4,600.00	0.0006%
Common	Ma. Edwina C. Laperal	107,000.00	0.00402%
Common	Honorio O. Reyes-Lao	35,000.00	0.00132%
Common	Antonio Jose U. Periquet	25,000.00	0.00094%

AGGREGATE OWNERSHIP OF ALL DIRECTORS AS A GROUP

367,600.00 0.0138%

b. Owners owning 5% or more of the voting stocks of the Corporation as of December 31, 2013.

Name and Address of	Amount/Nature of	Percent
---------------------	------------------	---------

Title of Class	Beneficial Owner	Beneficial Ownership	of Class
Common	Dacon Corporation (Fil) c/o Isidro A. Consunji 2281 Pasong Tamo Ext. Makati City	1,215,393,901.00	45.7690%
Common	PCD Nominee Corp. (Fil) G/F Makati Stock Exchange Bldg., 6767 Ayala Ave., Makati City	465,397,483.00	17.5258%
Common	DFC Holdings, Inc. (Fil) c/o Cristina C. Gotianun 2281 Pasong Tamo Ext. Makati City	461,999,838.00	17.3979%
Common	PCD Nominee Corp. (For) G/F Makati Stock Exchange Bldg., 6767 Ayala Avenue, Makati City	443,210,923.00	16.6903%

Below is the list of the individual beneficial owners under PCD account who holds more than 5% of the voting securities of Registrant.-

Common	BDO Securities Corp. (Fil) 2th Floor Tower One & Exchange Plaza, Ayala Avenue Makati City	198,669,366.00	7.4814%
Common	Deutsche Bank 26/F Ayala Tower One Ayala Avenue, Makati City	152,644,612.00	5.7482%
Common	The Hongkong & Shanghai Banking Corp. 12 th Floor The Enterprise Center Tower I 6766 Ayala Ave. Makati City	171,230,021.00	9.2970%

c. Changes in Control – NONE

d. Certain Relationships and Related Transactions

2013 Third Quarter Financial Statements

In the regular course of business, the Group's significant transactions with related parties consisted primarily of the following:

(a) Comprehensive surety, corporate and letters of guarantee issued by the Company and DMCI for various credit facilities granted to and for full performance of certain obligations by certain related parties.

(b) Certain assets of the Group, associates and other related parties were placed under accommodation mortgages to secure the indebtedness of the Group, its associates and other related parties.

(c) Interest and non interest-bearing cash and operating advances made by the Group to and from various associates and other related parties.

(d) Engineering and construction works of the water business is contracted to the construction segment of the Company. These projects are bid out to various contractors and are awarded on arms length transactions. The interrelated contracts amounted to Php 1,405,339,635.33 and Php 1,480,481,872.21 as of September 30, 2013 and September 30, 2012 respectively, where Php 345,671,606.16 and Php 580,869,719.69 were booked for the period ended September 30, 2013 and September 30, 2012 respectively.

Audited Financial Statements 2013

Related parties are considered to be related if one party has the ability, directly or indirectly, to control the other party or exercise significant influence over the other party in making the financial and operating decisions. Parties are also considered to be related if they are subject to common control or common significant influence. Related parties may be individuals or corporate entities.

Transactions entered into by the Group with related parties are at arm's length and have terms similar to the transactions entered into with third parties. In the regular course of business, the Group's significant transactions with related parties include the following:

(a) In December 2013, DMC sold various property, plant and equipment on account to BNC, an associate of TMC, which will be used for its mining operations in Palawan.

(b) In 2013 and 2012, DMCI is engaged in the construction of Tarlac - Pangasinan - La Union Toll Expressway (TPLEX) through PIDC an associate of the Group.

Related contract revenue recorded by DMCI on PIDC amounted to ₱1,223.15 million and ₱653.30 million in 2013 and 2012, respectively.

DMCI has outstanding receivables from PIDC amounting to ₱287.01 million and ₱170.02 million as of December 31, 2013 and 2012, respectively.

Retention receivable and advances to contract owners amounted to ₱98.53 million and ₱1.98 million as of December 31, 2013 and ₱104.90 million and ₱12.87 million as at December 31, 2012, respectively.

Unliquidated advances from contract owners amounted to ₱29.29 million and ₱57.60 million as at December 31, 2013 and 2012, respectively.

(c) Receivable from DMC Urban Property Developers, Inc. (UPDI), an affiliate under common stockholder amounted to ₱19.21 million and ₱187.30 million as at December 31, 2013 and 2012, respectively.

In 2013, UPDI had transactions with SMC representing long-term lease on office space and other transactions rendered to SMC necessary for the coal operations.

(d) DMC-Construction Equipment Resources, Inc. (DMC-CERI), an affiliate, under common

stockholder, has transactions with SMC for services rendered relating to the SMC's coal operations. These services are for the confirmatory drilling for coal reserve evaluation of identified potential areas, exploratory drilling of other minerals within Semirara Island, dewatering well drilling along cut-off wall of Panian mine and fresh water well drilling for industrial and domestic supply under an agreement.

DMC-CERI also provides to SMC marine vessels for use in the delivery of coal to its various customers. The coal freight billing is on a per metric ton basis plus demurrage charges when delay will be incurred in the loading and unloading of coal cargoes.

The outstanding receivable of DMC from DMC-CERI pertains to repairs and maintenance, fuel and materials and meal allowances of barge and tugboat crews incurred, which are initially paid by DMC in behalf of DMC-CERI. The outstanding receivable is included in "Receivable from related parties" under "Receivables" account in the consolidated statements of financial position.

(e) Asia Industries Inc., an affiliate, under common stockholder, had transactions with the Group for the rental of office and parking spaces to which related expenses are included in "Operating expenses" in the consolidated statements of income. The outstanding balance to Asia Industries, Inc. is lodged under "Payable to related parties" in the consolidated statements of financial position.

(f) M&S Company, Inc. (M&S), an affiliate under common control, provides various supplies and materials to DMC in cash on delivery basis. M&S also rents out various equipment used in DMC's operations. This is included in "Cost of sales and services" in the consolidated statements of income.

(g) Dacon, a shareholder of the Parent Company, provided maintenance of the Group's accounting system, Navision, to which related expenses are included under "Others" of "Operating expenses" in the consolidated statements of income.

(h) Royal Star Aviation Inc. transports SMC's visitors and employees from Manila to Semirara Island and vice versa and bills the related party for the utilization costs of the aircrafts. The related expenses are included in "Cost of sales and services" in the consolidated statements of income. The outstanding balance to Royal Star Aviation, Inc. is included in "Payable to related parties" in the consolidated statements of financial position.

(i) Prominent Fruits, Inc. supplies various office supplies and refreshments to SMC. The outstanding balance to Prominent Fruits, Inc. is included under "Payable to related parties" in the consolidated statements of financial position.

(j) Payable to Sirawai pertains to labor charges incurred by DMC, which are initially paid by Sirawai in behalf of DMC. The outstanding payable to Sirawai is recorded in "Payable to related parties" in the consolidated statements of financial position.

Terms and conditions of transactions with related parties

Outstanding balances as of December 31, 2013 and 2012, which are unsecured and interest free, are all due within one year. As of December 31, 2013 and 2012, the Parent Company has not made any provision for impairment loss relating to amounts owed by related parties. This assessment is undertaken each financial year through examining the financial position of the related party and the market in which the related party operates.

PART IV - EXHIBITS AND SCHEDULES

Item 13. Exhibits and Reports on SEC Form 17-C

(a) **Exhibits** - See accompanying index to exhibits

(b) **Reports on SEC Form 17-C** - The list of the reports from the preceding period December 31, 2013 is herein incorporated by reference.

(9) Material Contracts – **NONE**

SIGNATURES

Pursuant to the requirements of Section 17 of the Code and Section 141 of the Corporation Code, this report is signed on behalf of the issuer by the undersigned, thereunto duly authorized, in the City of Makati on April 25, 2014.

By:

Isidro A. Consunji
 President and CEO
 (Principal Chief Executive Officer/
 Principal Chief Operating Officer)

Aldric G. Borlaza
 Senior Finance Officer
 (Principal Comptroller)

Atty. Noel A. Laman
 Corporate Secretary

Herbert M. Consunji
 Vice President & Chief Finance Officer
 (Principal Chief Finance Officer)



Ma. Luisa C. Austria
 Accounting Officer
 (Principal Accounting Officer)

SUBSCRIBED AND SWORN to before me this APR 25 2014 day of _____ 2014 affiants exhibiting to me his/their Residence Certificates, as follows:

NAMES	RES. CERT. NO. Passport No.	DATE OF ISSUE	PLACE OF ISSUE
Isidro A. Consunji	02302563	03-12-14	Makati
Herbert M. Consunji	XX5507569	02-11-10	Manila
Aldric G. Borlaza	EB3244844	08-03-11	Manila
Ma. Luisa C. Austria	10846469	01-06-14	Makati
Atty. Noel A. Laman	02259051	02-11-14	Makati

Doc. No. 491
 Page No. 3
 Book No. 10
 Series of 2014



MARIO B. ESPIRITU, JR.
 Notary Public
 Makati City, Philippines
 PTR No. 4
 IBP No.

**INDEX TO EXHIBITS
FORM 17-A**

Number	Particulars
1	List of the Top 20 shareholders of the Company
2	List of reports filed under SEC Form 17-C

**LIST OF TOP 20 STOCKHOLDERS
AS OF DECEMBER 31, 2013**

	NAME	No. Of Shares	PERCENTAGE
1.	DACON CORPORATION	1,215,393,901	45.769%
2.	PCD NOMINEE CORPORATION (FILIPINO)	465,397,483	17.525%
3.	DFC HOLDINGS, INC.	461,999,838	17.398%
4.	PCD NOMINEE CORPORATION (FOREIGN)	443,210,923	16.690%
5.	DMCI RETIREMENT PLAN	19,980,000	0.752%
6.	FERNWOOD INVESTMENT, INC.	14,263,376	0.537%
7.	BERIT HOLDINGS CORPORATION	12,220,000	0.460%
8.	AUGUSTA HOLDINGS, INC.	3,800,334	0.143%
9.	DOUBLE SPRING INVESTMENTS CORPORATION	3,547,749	0.133%
10.	DMCI RETIREMENT FUND	2,600,000	0.097%
11.	MA. EDWINA/MIGUEL DAVID C. LAPERAL	550,000	0.021%
12.	YNTALCO REALTY DEVT. CORPORATION	500,000	0.019%
13.	BENIGNO DELA VEGA	410,000	0.015%
14.	AO ZHENG	368,000	0.014%
15.	XIUFEN LI	366,000	0.014%
16.	MAKATI SUPERMARKET CORP.	345,500	0.013%
17.	ENRIQUE G. FILAMORE	314,000	0.012%
18.	REGINA CAPITAL DEVELOPMENT	290,000	0.011%
19.	WINDERMERE HOLDINGS, INC.	242,175	0.010%
20.	ANTONIO L. GO	220,000	0.009%

DMCI Holdings, Inc.
Summary of Submittals of SEC Form 17-C
For the Year 2013

Date	Nature of Report
January 2, 2013	Preferred shares redemption for the month of December
January 3, 2013	DMC share transactions of a Director
January 7, 2013	DMC share transactions of a Director
January 17, 2013	Certification on Corporate Governance
January 17, 2013	Board Attendance 2012
January 18, 2013	DMC share transactions of an Officer
January 18, 2013	DMC share transactions of a Director
January 23, 2013	DMC share transactions of an Officer
January 23, 2013	DMC share transactions of a Director
January 25, 2013	DMC share transactions of an Officer
January 25, 2013	DMC share transactions of a Director
January 25, 2013	DMC share transactions of a Director
January 30, 2013	DMC share transactions of an Officer
January 30, 2013	DMC share transactions of a Director
January 30, 2013	DMC share transactions of a Director
February 2, 2013	Preferred shares redemption for the month of January
February 8, 2013	DMC share transactions of an Officer
February 8, 2013	DMC share transactions of DFC Holdings, Inc.
February 8, 2013	DMC share transactions of Director
February 8, 2013	DMC share transactions of Director
February 13, 2013	DMC share transactions of DFC Holdings, Inc.
February 13, 2013	MPIC-DMCI Concluded Maynilad Sale
February 18, 2013	DMCI Mining increases stake in Toledo Mining
February 27, 2013	DMC share transactions of DFC Holdings, Inc.
February 27, 2013	DMCI bags contract from Ortigas Company
March 1, 2013	Preferred Shares report for the month of February
March 6, 2013	Final Document Offer of DMCI Mining to TMC
March 7, 2013	DMC share transactions of Director/Vice Chairman
March 21, 2013	Board Committees for 2013
April 2, 2013	Preferred Shares report for the month of March
April 11, 2013	Annual Stockholders' Meeting Date and Declaration of Cash Dividends

April 12, 2013	DMCI signed EPC with SLTEC-TransAsia
May 6, 2013	Preferred Shares report for the month of April
June 3, 2013	DMC share transactions of an Officer
June 3, 2013	Preferred Shares report for the month of May
June 7, 2013	DMC share transactions of DFC Holdings, Inc
June 7, 2013	DMC share transactions of a Director
June 11, 2013	DMC share transactions of DFC Holdings, Inc
June 11, 2013	DMC share transactions by Director
June 17, 2013	DMC share transactions by an Officer
June 17, 2013	DMC share transactions of DFC Holdings, Inc
June 17, 2013	DMC share transactions by a Director
June 17, 2013	DMC share transactions by a Director
June 18, 2013	Deed of Assignment of Shares of SemCalaca Res
June 19, 2013	DMC share transactions by an Officer
June 19, 2013	DMC share transactions of DFC Holdings, Inc
June 19, 2013	DMC share transactions by Director/President
June 19, 2013	DMC share transactions by a Director
June 19, 2013	DMC share transactions by a Director
June 21, 2013	DMC share transactions by Director/President
June 21, 2013	DMC share transactions by Director
June 25, 2013	DMC share transactions of DFC Holdings, Inc
June 27, 2013	DMC share transactions by an Officer
July 2, 2013	DMC share transactions by an Officer
July 2, 2013	DMC share transactions by Director/President
July 2, 2013	Preferred Shares report for the month of June
July 2, 2013	DMCI Power declared as lone bidder for Mindoro Power Plant
July 22, 2013	DMCI signed EPC for NAIA Expressway Project
July 29, 2013	DMC share transactions by an Officer
July 30, 2013	DMC share transactions by an Officer
July 31, 2013	ASM Results
August 2, 2013	Preferred Shares report for the month of July
August 13, 2013	DMC share transactions of DFC Holdings, Inc
August 29, 2013	Certification of Independent Directors
September 2, 2013	Preferred Shares report for the month of August
September 10, 2013	DMC share transactions of DFC Holdings, Inc

September 12, 2013	DMC share transactions of Dacon Corp.
September 13, 2013	Maynilad Official Statement on Rate Rebasng
September 13, 2013	DMC share transactions of DFC Holdings, Inc
September 13, 2013	DMC share transactions by an Officer
September 16, 2013	DMC share transactions of DFC Holdings, Inc
September 16, 2013	DMC share transactions by an Officer
September 18, 2013	DMC share transactions of DFC Holdings, Inc
September 18, 2013	DMC share transactions by an Officer
September 18, 2013	DMC share transactions by a Director/President
September 23, 2013	DMC share transactions of DFC Holdings, Inc
September 26, 2013	DMC share transactions by an Officer
September 26, 2013	DMC share transactions by a Director/President
September 26, 2013	DMC share transactions of DFC Holdings, Inc
October 1, 2013	Preferred Shares report for the month of September
October 4, 2013	Audit Committee Assessment 2013
October 4, 2013	Maynilad files arbitration notice
October 14, 2013	DMC share transactions of DFC Holdings, Inc
October 16, 2013	DMC share transactions of DFC Holdings, Inc
October 17, 2013	DMC share transactions by an Officer
October 21, 2013	Ormeco awarded ESA to DMCI Power
October 30, 2013	DMC share transactions by an Officer
October 30, 2013	DMC share transactions of DFC Holdings, Inc
October 30, 2013	DMC share transactions by a Director/Officer
November 4, 2013	Preferred Shares report for the month of October
November 4, 2013	DMC share transactions by an Officer
November 14, 2013	Declaration of Special Cash Dividends
November 14, 2013	DMC share transactions by an Officer
December 4, 2013	Preferred Shares report for the month of November
December 18, 2013	DMC share transactions by an Officer



DMCI HOLDINGS
I N C O R P O R A T E D

3rd floor
DACON Building
2281 Don Chino Roces Ave.
(formerly Pasong Tamo Ext.)
Makati City 1231, Philippines

(632) 888 • DMCI
(632) 888 • 3000
Facsimile
(632) 816 • 7362
E-Mail
dmci@dmcinet.com

STATEMENT OF MANAGEMENT'S RESPONSIBILITY FOR CONSOLIDATED FINANCIAL STATEMENTS

The management of DMCI HOLDINGS, INC. is responsible for the preparation and fair presentation of the consolidated financial statements for the years ended December 31, 2013, 2012 and 2011, including the additional components attached therein, in accordance with Philippine Financial Reporting Standards. This responsibility includes designing and implementing internal controls relevant to the preparation and fair presentation of the consolidated financial statements that are free from material misstatement, whether due to fraud or error, selecting and applying appropriate accounting policies, and making accounting estimates that are reasonable in the circumstances.

The Board of Directors reviews and approves the consolidated financial statements and submits the same to the stockholders.

SyCip Gorres Velayo & Co., the independent auditors appointed by the stockholders has examined the consolidated financial statements of the company in accordance with Philippine Standards on Auditing, and in their reports to the stockholders, has expressed its opinion on the fairness of presentation upon completion of such examination.

DAVID M. CONSUNJI
Chairman of the Board

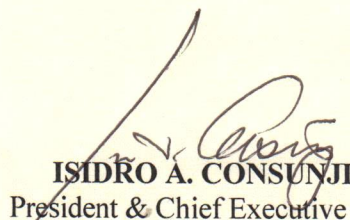
ISIDRO A. CONSUNJI
President & Chief Executive Officer

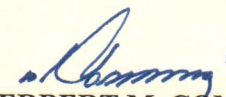
HERBERT M. CONSUNJI
Vice President & Chief Financial Officer

Signed this April 3, 2014.

Subsidiaries
D.M. Consunji, Inc.,
DMCI Project
Developers, Inc.
Atlantic, Gulf &
Pacific, Company
of Manila, Inc.
Semirara Mining
Corporation

22 APR 2014

SUBSCRIBED AND SWORN to before me this _____ day of _____ 2014 in Makati City, affiant exhibiting to me their Community Tax Certificates / Passport No. which are as follows:

DAVID M. CONSUNJI	EB0531746	July 7, 2010	DFA Manila
ISIDRO A. CONSUNJI	02302563	March 12, 2014	Makati City
HERBERT M. CONSUNJI	10851684	January 9, 2014	Makati City

Doc. No. 151
Page No. 37
Book No. 198
Series of 2014

RUBEN T.M. RAMIREZ
NOTARY PUBLIC
UNTIL DEC. 31, 2015
2734 M. AURORA ST., MAKATI CITY
IBP NO. 942556 / CY-2014
ROLL NO. 28947/MCLE-4 NO. 0006324/6-19-12
PTR NO. MKT. 4225649/1-2-14 MAKATI CITY



CERTIFICATION

3rd floor
DACON Building
2281 Don Chino Roces Ave.
(formerly Pasong Tamo Ext.)
Makati City 1231, Philippines

(632) 888 • 3000
Facsimile
(632) 816 • 7362
E-Mail
investor_inquiries@dmcinet.com

I, Ms. **MA. EDWINA C. LAPERAL**, of legal age, Filipino and with office address at 3rd Floor, Dacon Bldg., 2281 Don Chino Roces Avenue, Makati City, after being sworn to in accordance with law, do hereby certify that:

1. I am the Treasurer of DMCI Holdings, Inc., a corporation duly created and existing under and by virtue of the laws of the Republic of the Philippines, under SEC Certificate of Registration No. AS095-002283 with principal office address at 3rd Floor Dacon Bldg., 2281 Don Chino Roces Avenue, Makati.
2. The General Form for Financial Statements (GFFS) in compact disc (CD) submitted herein has the basic and material data in the audited and financial statements.
3. I am executing this certification to attest to the truth of the foregoing and in compliance with the reportorial requirements of the Securities and Exchange Commission.

Done this 11th day of April, 2014 in Makati City.

MA. EDWINA C. LAPERAL

Subscribed and sworn to before me this 121 APR 2014 day of _____, 2014 affiant exhibiting to me his/her Community Tax No. 10857243 on January 13, 2014 in Makati City.

Doc. No. 62
Page No. 14
Book No. 198
Series of 2014

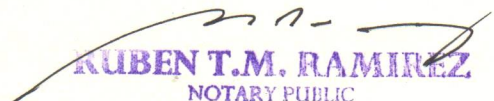
RUBEN T.M. RAMIREZ
NOTARY PUBLIC
UNTIL DEC. 31, 2015
2734 M. AURORA ST., MAKATI CITY
IBP NO. 942556 / CY-2014
ROLL NO. 28947/MCLE-4 NO. 0006324/6-19-12
PTR NO. MKT. 4225649/1-2-14 MAKATI CITY

SPECIAL FORM FOR FINANCIAL STATEMENTS OF PUBLICLY-HELD AND INVESTMENT COMPANIES

NAME OF CORPORATION: DMCI HOLDINGS, INC. AND SUBSIDIARIES (Consolidated)
CURRENT ADDRESS: 3rd Floor, Dacon Building, 2281 Don Chino Roces Avenue, Makati City
TEL. NO.: 818-3000 FAX NO.: _____
COMPANY TYPE : Holding Company PSIC: _____

If these are based on consolidated financial statements, please so indicate in the caption.

Table 1. Consolidated Balance Sheet

FINANCIAL DATA	2013 (in P'000)	2012 (in P'000)
A. ASSETS (A.1 + A.2 + A.3 + A.4 + A.5 + A.6 + A.7 + A.8 + A.9 + A.10)	123,750,759	96,984,086
A.1 Current Assets (A.1.1 + A.1.2 + A.1.3 + A.1.4 + A.1.5)	71,185,790	49,225,654
A.1.1 Cash and cash equivalents (A.1.1.1 + A.1.1.2 + A.1.1.3)	24,774,495	9,717,042
A.1.1.1 On hand	27,182	41,074
A.1.1.2 In domestic banks/entities	8,052,780	2,834,687
A.1.1.3 Short-term investments	16,694,533	6,841,281
A.1.2 Trade and Other Receivables (A.1.2.1 + A.1.2.2)	14,961,082	11,435,341
A.1.2.1 Due from domestic entities (A.1.2.1.1 + A.1.2.1.2 + A.1.2.1.3 + A.1.2.1.4 + A.1.2.1.5)	14,961,082	11,435,341
A.1.2.1.1 Due from customers (trade)	15,150,268	10,945,547
A.1.2.1.2 Due from related parties	131,596	187,296
A.1.2.1.3 Advances to officers and employees	40,695	60,048
A.1.2.1.4 Others, specify (A.1.2.1.3.1 + A.1.2.1.3.2)	184,340	482,927
A.1.2.1.3.1 Other receivables	184,340	482,927
A.1.2.1.3.2	-	-
A.1.2.1.5 Allowance for doubtful accounts (negative entry)	(545,817)	(240,477)
A.1.2.2 Due from foreign entities, specify	-	-
A.1.2.2.1	-	-
A.1.2.2.2	-	-
A.1.2.2.3	-	-
A.1.2.2.4 Allowance for doubtful accounts (negative entry)	-	-
A.1.3 Inventories (A.1.3.1 + A.1.3.2 + A.1.3.3 + A.1.3.4 + A.1.3.5 + A.1.3.6)	23,171,833	21,515,161
A.1.3.1 Real estate held for sale and development	17,877,412	15,510,158
A.1.3.2 Coal inventory	1,938,052	2,346,396
A.1.3.3 Equipment parts, materials & supplies in transit	3,308,358	3,638,185
A.1.3.4 Nickle Ore	48,011	20,422
A.1.3.5	-	-
A.1.3.6 Others, specify (A.1.3.6.1 + A.1.3.6.2)	-	-
A.1.3.6.1	-	-
A.1.3.6.2	-	-
A.1.4 Financial Assets other than Cash/Receivables/Equity investments (A.1.4.1 + A.1.4.2 + A.1.4.3 + A.1.4.4 + A.1.4.5 + A.1.4.6)	133,129	159,813
A.1.4.1 Financial Assets at Fair Value through Profit or Loss - issued by domestic entities:	73,150	71,260
A.1.4.1.1 National Government	-	-
A.1.4.1.2 Public Financial Institutions	-	-
A.1.4.1.3 Public Non-Financial Institutions	-	-
A.1.4.1.4 Private Financial Institutions	73,150	71,260
A.1.4.1.5 Private Non-Financial Institutions	-	-
A.1.4.2 Held to Maturity Investments - issued by domestic entities:	-	-
A.1.4.2.1 National Government	-	-
A.1.4.2.2 Public Financial Institutions	-	-
A.1.4.2.3 Public Non-Financial Institutions	-	-
A.1.4.2.4 Private Financial Institutions	-	-
A.1.4.2.5 Private Non-Financial Institutions	-	-

NOTE:

This special form is applicable to Investment Companies and Publicly-held Companies (enumerated in Section 17.2 of the Securities Regulation Code (SRC), except banks and insurance companies). As a supplemental form to PHFS, it shall be used for reporting Consolidated Financial Statements of Parent corporations and their subsidiaries.

Domestic corporations are those which are incorporated under Philippine laws or branches/subsidiaries of foreign corporations that are licensed to do business in the Philippines where the center of economic interest or activity is within the Philippines. On the other hand, foreign corporations are those that are incorporated abroad, including branches of Philippine corporations operating abroad.

Financial Institutions are corporations principally engaged in financial intermediation, facilitating financial intermediation, or auxiliary financial services. Non-Financial institutions refer to corporations that are primarily engaged in the production of market goods and non-financial services

SPECIAL FORM FOR FINANCIAL STATEMENTS OF PUBLICLY-HELD AND INVESTMENT COMPANIES

NAME OF CORPORATION: DMCI HOLDINGS, INC. AND SUBSIDIARIES (Consolidated)
CURRENT ADDRESS: 3rd Floor, Dacon Building, 2281 Don Chino Roces Avenue, Makati City
TEL. NO.: 818-3000 FAX NO.: _____
COMPANY TYPE : Holding Company PSIC: _____

If these are based on consolidated financial statements, please so indicate in the caption.

Table 1. Consolidated Balance Sheet

FINANCIAL DATA	2013 (in P'000)	2012 (in P'000)
A.1.4.3 Loans and Receivables - issued by domestic entities:	-	-
A.1.4.3.1 National Government	-	-
A.1.4.3.2 Public Financial Institutions	-	-
A.1.4.3.3 Public Non-Financial Institutions	-	-
A.1.4.3.4 Private Financial Institutions	-	-
A.1.4.3.5 Private Non-Financial Institutions	-	-
A.1.4.4 Available-for-sale financial assets - issued by domestic entities:	59,979	88,553
A.1.4.4.1 National Government	-	-
A.1.4.4.2 Public Financial Institutions	-	-
A.1.4.4.3 Public Non-Financial Institutions	-	-
A.1.4.4.4 Private Financial Institutions	59,979	88,553
A.1.4.4.5 Private Non-Financial Institutions	-	-
A.1.4.5 Financial Assets issued by foreign entities:	-	-
A.1.4.5.1 Financial Assets at Fair Value through Profit or Loss	-	-
A.1.4.5.2 Held-to-maturity Investments	-	-
A.1.4.5.3 Loans and Receivables	-	-
A.1.4.5.4 Available-for-sale Financial Assets	-	-
A.1.4.6 Allowance for decline in market value (negative entry)	-	-
A.1.5 Other Current Assets (state separately material items) (A.1.5.1 + A.1.5.2 + A.1.5.3)	8,145,251	6,398,297
A.1.5.1 Costs and estimated earnings in excess of billings on uncompleted contracts	986,359	919,932
A.1.5.2 Other current assets	7,158,892	5,478,365
A.1.5.3	-	-
A.2 Property, plant, and equipment (A.2.1 + A.2.2 + A.2.3 + A.2.4 + A.2.5 + A.2.6 + A.2.7+ A.2.8)	31,271,246	25,724,232
A.2.1 Land and Land Improvements	2,052,652	1,558,027
A.2.2 Power Plant, Buildings and Building Improvements	20,928,376	18,973,630
A.2.3 Construction Equipment, Machinery and Tools	6,418,844	5,301,420
A.2.4 Office Furniture, Fixtures and Equipment	417,889	374,259
A.2.5 Others, specify (A.2.5.1 + A.2.5.2 + A.2.5.3 + A.2.5.4 + A.2.5.5)	27,095,396	21,323,820
A.2.5.1 Transportation Equipment	393,285	350,272
A.2.5.2 Conventional and Continuous Mining Properties and Equipment	15,553,087	15,228,638
A.2.5.3 Leasehold Improvements	165,691	142,198
A.2.5.4 Mine Properties	133,189	-
A.2.5.5 Constructiobn in Progress	10,850,144	5,602,712
A.2.6 Appraisal increase, specify (A.2.6.1 + A.2.6.2 + A.2.6.3 + A.2.6.4 + A.2.6.5)	-	-
A.2.6.1	-	-
A.2.6.2	-	-
A.2.6.3	-	-
A.2.6.4	-	-
A.2.6.5	-	-
A.2.7 Accumulated Depreciation (negative entry)	(25,641,911)	(21,806,924)
A.2.8 Impairment Loss or Reversal (if loss, negative entry)	-	-
A.3 Investments accounted for using the equity method (A.3.1 + A.3.2 + A.3.3)	11,883,288	14,369,254
A.3.1 Equity in domestic subsidiaries/affiliates	-	-
A.3.2 Equity in foreign branches/subsidiaries/affiliates	-	-
A.3.3 Others, specify (A.3.3.1 + A.3.3.2 + A.3.3.3 + A.3.3.4 + A.3.3.5)	11,883,288	14,369,254
A.3.3.1 Investment in Associates and Joint Ventures	4,598,596	6,836,841
A.3.3.2 Accumulated Equity in net earnings (losses)	7,292,520	7,540,241
A.3.3.3 Allowance for probable losses (negative entry)	(7,828)	(7,828)
A.3.3.4	-	-
A.3.3.5	-	-
A.4 Investment Property	270,175	276,447
A.5 Biological Assets	-	-
A.6 Intangible Assets	33,598	49,945
A.6.1 Major item/s, specify (A.6.1.1 + A.6.1.2)	33,598	49,945
A.6.1.1 Software costs	33,598	49,945
A.6.1.2	-	-
A.6.2 Others, specify (A.6.2.1 + A.6.2.2)	-	-
A.6.2.1	-	-
A.6.2.2	-	-
A.7 Assets Classified as Held for Sale	-	-
A.8 Assets included in Disposal Groups Classified as Held for Sale	-	-

SPECIAL FORM FOR FINANCIAL STATEMENTS OF PUBLICLY-HELD AND INVESTMENT COMPANIES

NAME OF CORPORATION: DMCI HOLDINGS, INC. AND SUBSIDIARIES (Consolidated)
CURRENT ADDRESS: 3rd Floor, Dacon Building, 2281 Don Chino Roces Avenue, Makati City
TEL. NO.: 818-3000 FAX NO.: _____
COMPANY TYPE : Holding Company PSIC: _____

If these are based on consolidated financial statements, please so indicate in the caption.

Table 1. Consolidated Balance Sheet

FINANCIAL DATA	2013 (in P'000)	2012 (in P'000)
A.9 Long-term receivables (net of current portion) (A.9.1 + A.9.2 + A.9.3)	5,186,785	5,242,743
A.9.1 From domestic entities, specify (A.9.1.1 + A.9.1.2 + A.9.1.3)	5,186,785	5,242,743
A.9.1.1 Due from customers (trade)	5,186,785	5,242,743
A.9.1.2	-	-
A.9.1.3	-	-
A.9.2 From foreign entities, specify (A.9.2.1 + A.9.2.2 + A.9.2.3)	-	-
A.9.2.1	-	-
A.9.2.2	-	-
A.9.2.3	-	-
A.9.3 Allowance for doubtful accounts, net of current portion (negative entry)	-	-
A.10 Other Assets (A.10.1 + A.10.2 + A.10.3 + A.10.4 + A.10.5)	3,919,877	2,095,811
A.10.1 Available-for-Sale Financial Assets	950	-
A.10.2 Deferred Tax Assets - net	197,599	23,218
A.10.3 Pension Assets	796,723	684,791
A.10.4 Others, specify (A.10.4.1 + A.10.4.2 + A.10.4.3 + A.10.4.4+A.10.4.5)	2,924,605	1,387,802
A.10.4.1 Other Noncurrent Assets	2,924,605	1,387,802
A.10.4.2	-	-
A.10.4.3	-	-
A.10.4.4	-	-
A.10.4.5	-	-
A.10.5 Allowance for write-down of deferred charges/bad accounts (negative entry)	-	-
B. LIABILITIES (B.1 + B.2 + B.3 + B.4 + B.5)	63,547,682	48,227,994
B.1 Current Liabilities (B.1.1 + B.1.2 + B.1.3 + B.1.4 + B.1.5 + B.1.6 + B.1.7)	28,865,344	27,344,422
B.1.1 Trade and Other Payables to Domestic Entities (B.1.1.1 + B.1.1.2 + B.1.1.3 + B.1.1.4 + B.1.1.5 + B.1.1.6)	13,764,063	12,300,693
B.1.1.1 Suppliers and Subcontractors	5,128,238	7,035,245
B.1.1.2 Other Trade Payables	574,878	511,776
B.1.1.3 Output VAT Payable	1,410,799	543,445
B.1.1.4	-	-
B.1.1.5 Accruals, specify material items (B.1.1.5.1 + B.1.1.5.2 + B.1.1.5.3)	6,650,148	4,210,227
B.1.1.5.1 Accrued Construction Cost	4,775,876	2,578,564
B.1.1.5.2 Payable to Department of Energy	877,948	1,007,849
B.1.1.5.3 Others	996,324	623,814
B.1.1.6 Others, specify (B.1.1.6.1 + B.1.1.6.2 + B.1.1.6.3)	-	-
B.1.1.6.1	-	-
B.1.1.6.2	-	-
B.1.1.6.3	-	-
B.1.2 Trade and Other Payables to Foreign Entities (specify) (B.1.2.1 + B.1.2.2 + B.1.2.3)	-	-
B.1.2.1	-	-
B.1.2.2	-	-
B.1.2.3	-	-
B.1.3 Provisions	-	-
B.1.4 Financial Liabilities (excluding Trade and Other Payables and Provisions) (B.1.4.1 + B.1.4.2 + B.1.4.3 + B.1.4.4 + B.1.4.5)	6,424,633	8,265,827
B.1.4.1 Short-term Debt	2,119,296	632,971
B.1.4.2 Current Portion of Liabilities for Purchased Land	885,088	929,379
B.1.4.3 Current Portion of Long-term Debt	3,386,257	6,642,262
B.1.4.4 Payable to Related Parties	33,992	61,215
B.1.4.5	-	-
B.1.5 Liabilities for Current Tax	66,182	89,442
B.1.6 Deferred Tax Liabilities	-	-
B.1.7 Others, specify (If material, state separately; indicate if the item is payable to public/private or financial/non-financial institutions) (B.1.7.1 + B.1.7.2 + B.1.7.3 + B.1.7.4 + B.1.7.5 + B.1.7.6)	8,610,466	6,688,460
B.1.7.1 Billings in excess of costs and estimated earnings on uncompleted contracts	3,680,765	3,332,565
B.1.7.2 Customers' advances and deposits	4,929,701	3,355,895
B.1.7.3	-	-
B.1.7.4	-	-
B.1.7.5	-	-
B.1.7.6 Any other current liability in excess of 5% of Total Current Liabilities, specify: (B.1.7.6.1 + B.1.7.6.2 + B.1.7.6.3)	-	-
B.1.7.6.1	-	-
B.1.7.6.2	-	-
B.1.7.6.3	-	-

SPECIAL FORM FOR FINANCIAL STATEMENTS OF PUBLICLY-HELD AND INVESTMENT COMPANIES

NAME OF CORPORATION: DMCI HOLDINGS, INC. AND SUBSIDIARIES (Consolidated)
 CURRENT ADDRESS: 3rd Floor, Dacon Building, 2281 Don Chino Roces Avenue, Makati City
 TEL. NO.: 818-3000 FAX NO.: _____
 COMPANY TYPE : Holding Company PSIC: _____

If these are based on consolidated financial statements, please so indicate in the caption.

Table 1. Consolidated Balance Sheet

FINANCIAL DATA	2013 (in P'000)	2012 (in P'000)
B.2 Long-term Debt - Non-current Interest-bearing Liabilities (B.2.1 + B.2.2 + B.2.3 + B.2.4 + B.2.5)	31,258,586	18,190,853
B.2.1 Domestic Public Financial Institutions	-	-
B.2.2 Domestic Public Non-Financial Institutions	-	-
B.2.3 Domestic Private Financial Institutions	31,258,586	18,190,853
B.2.4 Domestic Private Non-Financial Institutions	-	-
B.2.5 Foreign Financial Institutions	-	-
B.3 Indebtedness to Affiliates and Related Parties (Non-Current)	-	-
B.4 Liabilities Included in the Disposal Groups Classified as Held for Sale	-	-
B.5 Other Liabilities (B.5.1 + B.5.2)	3,423,752	2,692,719
B.5.1 Liabilities for Purchased Land - net of current portion	487,389	215,945
B.5.2 Others, specify (B.5.2.1 + B.5.2.2 + B.5.2.3 + B.5.2.4 + B.5.2.5)	2,936,363	2,476,774
B.5.2.1 Pension	93,765	86,349
B.5.2.2 Other Noncurrent Liabilities	1,693,214	1,527,655
B.5.2.3 Deferred Tax Liabilities	1,149,384	862,770
B.5.2.4	-	-
B.5.2.5	-	-
C. EQUITY (C.3 + C.4 + C.5 + C.6 + C.7 + C.8 + C.9+C.10)	60,203,077	48,756,092
C.1 Authorized Capital Stock (no. of shares, par value and total value; show details) (C.1.1+C.1.2+C.1.3)	6,000,000	6,000,000
C.1.1 Common shares 5,900,000,000 shares, P1.00 par value	5,900,000	5,900,000
C.1.2 Preferred Shares 100,000,000 shares, P1.00 par value	100,000	100,000
C.1.3 Others	-	-
C.2 Subscribed Capital Stock (no. of shares, par value and total value) (C.2.1 + C.2.2 + C.2.3)	-	-
C.2.1 Common shares	-	-
C.2.2 Preferred Shares	-	-
C.2.3 Others	-	-
C.3 Paid-up Capital Stock (C.3.1 + C.3.2)	2,655,498	2,655,498
C.3.1 Common shares 2,655,494,000 issued shares in 2013 and 2012	2,655,494	2,655,494
C.3.2 Preferred Shares 3,780 issued shares in 2013 and 2012	4	4
C.4 Additional Paid-in Capital / Capital in excess of par value / Paid-in Surplus	4,765,317	4,765,317
C.5 Non-controlling Interests	8,910,307	7,451,109
C.6 Others, specify (C.6.1 + C.6.2 + C.6.3 + C.6.4)	330,096	251,009
C.6.1 Premium on Acquisition of Non-controlling Interests	(161,033)	(161,033)
C.6.2 Remeasurements on Retirement Plans - net of tax	516,675	383,132
C.6.3 Net Accumulated Unrealized Gains on AFS Financial Assets	6,830	28,910
C.6.4 Cumulative Translation Adjustment	(32,376)	-
C.7 Appraisal Surplus/Revaluation Increment in Property/Revaluation Surplus	-	-
C.8 Retained Earnings (C.8.1 + C.8.2)	43,541,859	33,633,159
C.8.1 Appropriated	2,100,000	4,600,000
C.8.2 Unappropriated	41,441,859	29,033,159
C.9 Head / Home Office Account (for Foreign Branches only)	-	-
C.10 Cost of Stocks Held in Treasury (negative entry)	-	-
TOTAL LIABILITIES AND EQUITY (B + C)	123,750,759	96,984,086

SPECIAL FORM FOR FINANCIAL STATEMENTS OF PUBLICLY-HELD AND INVESTMENT COMPANIES

NAME OF CORPORATION: DMCI HOLDINGS, INC. AND SUBSIDIARIES (Consolidated)CURRENT ADDRESS: 3rd Floor, Dacon Building, 2281 Don Chino Roces Avenue, Makati CityTEL. NO.: 818-3000

FAX NO.: _____

COMPANY TYPE : Holding Company

PSIC: _____

If these are based on consolidated financial statements, please so indicate in the caption.

Table 2. Consolidated Income Statement

FINANCIAL DATA	2013 (in P'000)	2012 (in P'000)	2011 (in P'000)
A. REVENUE / INCOME (A.1 + A.2 + A.3 + A.4)	68,906,507	56,034,424	51,565,281
A.1 Net Sales or Revenue / Receipts from Operations (manufacturing, mining, utilities, trade, services, etc.) (from Primary Activity)	55,970,630	51,739,879	47,802,585
A.2 Share in the Profit or Loss of Associates and Joint Ventures accounted for using the Equity Method	1,802,251	2,317,551	2,185,553
A.3 Other Revenue (A.3.1 + A.3.2 + A.3.3 + A.3.4 + A.3.5)	892,542	570,795	280,678
A.3.1 Forfeitures and cancellation of contracts	419,379	157,579	160,145
A.3.2 Management fee	10,890	3,131	55,308
A.3.3 Rental income	84,453	274,170	53,807
A.3.4 Dividend income	4,291	5,679	4,547
A.3.5 Others, specify (A.3.5.1 + A.3.5.2 + A.3.5.3 + A.3.5.4 + A.3.5.5 + A.3.5.6 + A.3.5.7 + A.3.5.8)	373,529	130,236	6,871
A.3.5.1 Despatch income	170,349	-	-
A.3.5.2 Sale of fly ash	203,180	130,236	6,871
A.3.5.3			
A.3.5.4			
A.3.5.5			
A.3.5.6			
A.3.5.7			
A.3.5.8			
A.4 Other Income (non-operating) (A.4.1 + A.4.2 + A.4.3 + A.4.4)	10,241,084	1,406,199	1,296,465
A.4.1 Interest Income	658,777	849,465	1,097,703
A.4.2 Recoveries from insurance claims	10,632	41,546	35,180
A.4.3 Gain / (Loss) from selling of Assets, specify (A.4.3.1 + A.4.3.2)	9,302,268	127,497	57,565
A.4.3.1 Gain on sale of investment	9,157,413	-	-
A.4.3.2 Gain on sale of property, plant and equipment - net	144,855	127,497	57,565
A.4.4 Others, specify	269,407	387,691	106,017
A.4.4.1 Gain on bargain purchase	31,041	-	-
A.4.4.2 Guarantee fee income	19,150	-	-
A.4.4.3 Pension income	430	54,481	37,707
A.4.4.4 Foreign exchange gain - net	-	332,447	-
A.4.4.5 Others	218,786	763	68,310
B. COST OF GOODS SOLD (B.1 + B.2 + B.3)	-	-	-
B.1 Cost of Goods Manufactured (B.1.1 + B.1.2 + B.1.3 + B.1.4 + B.1.5)	-	-	-
B.1.1 Direct Material Used	-	-	-
B.1.2 Direct Labor	-	-	-
B.1.3 Other Manufacturing Cost / Overhead	-	-	-
B.1.4 Goods in Process, Beginning	-	-	-
B.1.5 Goods in Process, End (negative entry)	-	-	-
B.2 Finished Goods, Beginning	-	-	-
B.3 Finished Goods, End (negative entry)	-	-	-
C. COST OF SALES (C.1 + C.2 + C.3 + C.4 + C.5 + C.6 + C.7 + C.8 + C.9)	15,496,140	16,016,911	15,703,721
C.1 Cost of real estate inventory	6,567,151	4,434,929	4,080,030
C.2 Materials and supplies	3,157,875	4,172,074	1,821,355
C.3 Fuel and lubricants	2,453,660	3,043,332	4,242,030
C.4 Depreciation and amortization	1,114,655	1,448,149	1,797,211
C.5 Outside services	740,963	967,163	1,410,563
C.6 Hauling, shiploading and handling costs	540,763	763,505	1,198,572
C.7 Direct labor	521,267	456,399	622,215
C.8 Production overhead	387,108	600,582	456,211
C.9 Others	12,698	130,778	75,534
D. COST OF SERVICES (D.1 + D.2 + D.3 + D.4 + D.5 + D.6 + D.7 + D.8 + D.9)	18,728,828	18,563,725	15,725,259
D.1 Materials and supplies	8,850,595	5,981,336	6,515,312
D.2 Outside services	4,359,274	6,498,218	2,751,187
D.3 Direct labor	1,582,222	1,327,040	1,638,495
D.4 Depreciation and amortization	1,515,350	1,554,596	1,097,976
D.5 Fuel and lubricants	1,050,377	2,110,596	997,184
D.6 Production overhead	988,879	649,682	1,171,005
D.7 Spot purchases	229,197	130,367	1,500,978
D.8 Hauling, shiploading and handling costs	-	214,913	6,955
D.9 Others	152,934	96,977	46,167
E. GROSS PROFIT (A - B - C - D)	34,681,539	21,453,788	20,136,301

NOTE: Pursuant to SRC Rule 68.1 (as amended in Nov. 2005), for fiscal years ending December 31, 2005 up to November 30, 2006, a comparative format of only two (2) years may be filed to give temporary relief for covered companies as the more complex PFRSs will be applied for the first time in these year end periods. After these first time applications, the requirement of three (3) year comparatives shall resume for year end reports beginning December 31, 2006 and onwards.

SPECIAL FORM FOR FINANCIAL STATEMENTS OF PUBLICLY-HELD AND INVESTMENT COMPANIES

NAME OF CORPORATION: DMCI HOLDINGS, INC. AND SUBSIDIARIES (Consolidated)
CURRENT ADDRESS: 3rd Floor, Dacon Building, 2281 Don Chino Roces Avenue, Makati City
TEL. NO.: 818-3000 FAX NO.: _____
COMPANY TYPE : Holding Company PSIC: _____

If these are based on consolidated financial statements, please so indicate in the caption.

Table 2. Consolidated Income Statement

FINANCIAL DATA	2011 (in P'000)	2010 (in P'000)	2009 (in P'000)
F. OPERATING EXPENSES (F.1 + F.2 + F.3 + F.4)	9,390,802	6,288,451	5,286,176
F.1 Government share	1,304,961	1,557,950	1,497,356
F.2 Depreciation and amortization	1,556,057	327,097	198,656
F.3 Salaries, wages and employee benefits	1,112,195	1,063,108	1,007,532
F.4 Other Expenses, specify (F.4.1 + F.4.2 + F.4.3 + F.4.4 + F.4.5 + F.4.6 + F.4.7 + F.4.8 + F.4.9 + F.4.10 + F.4.11 + F.4.12 + F.4.13 + F.4.14 + F.4.15 + F.4.16 + F.4.17)	5,417,589	3,340,296	2,582,632
F.4.1 Outside services	837,816	792,487	211,478
F.4.2 Repairs and maintenance	739,224	238,995	94,728
F.4.3 Commission	737,447	386,810	503,946
F.4.4 Taxes and licenses	638,735	530,723	677,460
F.4.5 Provision for doubtful accounts	443,650	78,296	15,178
F.4.6 Advertising and marketing	309,730	366,357	337,092
F.4.7 Rent	115,773	28,619	104,834
F.4.8 Communication, light and water	114,410	80,440	75,686
F.4.9 Entertainment, amusement and recreation	73,560	69,697	62,395
F.4.10 Insurance	66,347	61,687	68,172
F.4.11 Transportation and travel	62,285	54,507	47,292
F.4.12 Supplies	55,748	108,757	46,954
F.4.13 Association dues	39,834	40,081	50,276
F.4.14 Probable losses on other noncurrent assets	-	47,151	-
F.4.15 Loss on writedown of property, plant and equipment	443,349	341,146	-
F.4.16 Foreign exchange loss - net	356,121	-	46,567
F.4.17 Miscellaneous	383,560	114,543	240,574
G. FINANCE COSTS	929,328	1,198,528	1,261,885
H. NET INCOME (LOSS) BEFORE TAX (E - F - G)	24,361,409	13,966,809	13,588,240
I. INCOME TAX EXPENSE (negative entry)	(2,104,650)	(1,474,554)	(1,343,551)
J. INCOME (LOSS) AFTER TAX	22,256,759	12,492,255	12,244,689
K. Amount of (i) Post-Tax Profit or Loss of Discontinued Operations; and (ii) Post-Tax Gain or Loss Recognized on the Measurement of Fair Value less Cost to Sell or on the Disposal of the Assets or Disposal Group(s) constituting the Discontinued Operation (if any)	-	-	-
K.1	-	-	-
K.2	-	-	-
L. PROFIT OR LOSS ATTRIBUTABLE TO NONCONTROLLING INTERESTS	3,319,379	2,756,421	2,681,735
M. PROFIT OR LOSS ATTRIBUTABLE TO EQUITY HOLDERS OF THE PARENT	18,937,380	9,735,834	9,562,954
N. EARNINGS (LOSS) PER SHARE			
N.1 Basic	7.13	3.67	3.60
N.2 Diluted	-	-	-

SPECIAL FORM FOR FINANCIAL STATEMENTS OF PUBLICLY-HELD AND INVESTMENT COMPANIES

NAME OF CORPORATION: DMCI HOLDINGS, INC. AND SUBSIDIARIES (Consolidated)

CURRENT ADDRESS: 3rd Floor, Dacon Building, 2281 Don Chino Roces Avenue, Makati City

TEL. NO.: 818-3000

FAX NO.:

COMPANY TYPE: Holding Company

PSIC:

If these are based on consolidated financial statements, please so indicate in the caption.

Table 3. Consolidated Cash Flow Statements

FINANCIAL DATA	2011 (in P'000)	2010 (in P'000)	2009 (in P'000)
CASH FLOWS FROM OPERATING ACTIVITIES			
Net Income (Loss) Before Tax and Extraordinary Items	24,361,409	13,966,809	13,588,240
Adjustments to Reconcile Net Income to Net Cash Provided by Operating Activities			
Depreciation	4,186,062	3,329,842	3,093,843
Amortization, specify:			
Others, specify:			
Finance costs	929,328	1,198,528	1,261,885
Provisions for doubtful accounts	443,650	78,296	15,178
Loss on PPE writedown	443,349	341,146	-
Reversal of impairment on other noncurrent assets	(61,549)	-	-
Movement in net retirement asset	39,438	(156,320)	-
Writedown on investments in jointly controlled entities	409	-	-
Impairment of noncurrent assets	-	47,150	-
Gain on sale of investments	(9,157,413)	-	-
Equity in net earnings of associates and jointly controlled entity	(1,802,251)	(2,317,551)	(2,185,199)
Finance income	(658,777)	(849,864)	(1,097,703)
Net unrealized foreign exchange loss (gain)	(203,482)	(182,518)	18,974
Gain on sale property, plant and equipment	(144,855)	(127,497)	(57,565)
Gain on bargain purchase	(31,041)	-	-
Dividend income	(4,291)	(25,379)	(4,547)
Unrealized market loss (gain) on financial assets at FVPL	(1,890)	140	(1,400)
Gain on reversal of impairment on PPE	-	-	(6,670)
Loss on sale of available-for-sale financial assets	-	986	-
Changes in Assets and Liabilities:			
Decrease (Increase) in:			
Receivables	(1,794,532)	(5,652,933)	1,116,236
Inventories	(535,209)	(3,179,438)	(5,642,985)
Other current assets	(1,678,720)	(931,039)	(698,297)
Others, specify: Costs and estimated earnings in excess of billings on uncompleted contracts	(66,427)	329,347	(2,888)
Increase (Decrease) in:			
Accounts payable and accrued expenses	2,799,891	(217,989)	1,516,671
Others, specify: Customers' advances and deposits	1,573,806	1,619,541	(799,490)
Liabilities for purchased land	217,979	217,979	(498,574)
Billings in excess of costs and estimated earnings on uncompleted contracts	348,200	(395,497)	163,864
Others, specify:			
Interest received	325,147	852,289	1,080,363
Income taxes paid	(1,328,752)	(1,709,150)	(849,894)
Interest paid and capitalized as cost of inventory	(672,582)	(313,340)	(213,920)
A. Net Cash Provided by Operating Activities (sum of above rows)	17,526,897	5,923,538	9,796,122
CASH FLOWS FROM INVESTING ACTIVITIES			
Additions to:			
Investment in financial asset at FVPL	-	-	(70,000)
Property, plant and equipment	(10,247,891)	(6,165,489)	(3,539,342)
Investments in associates, jointly controlled entity and others	(1,029,334)	-	(1,300)
Investment properties	(25,939)	(139,197)	(32,138)
Available-for-sale financial assets	-	-	(7,105)
Proceeds from disposals of:			
Investments in associates, jointly controlled entity and others	8,227,483	-	-
Property and equipment	381,556	136,040	76,077
Available-for-sale financial assets (Note 6)	-	164,878	150
Others, specify: Dividends received	5,225,306	881,507	703,198
Increase in other noncurrent assets	(1,480,444)	-	(233,279)
Acquisition of a business - net of cash acquired (Note 11)	(1,622,171)	(2,576,811)	-
Interest paid and capitalized as cost of property, plant and equipment	(101,380)	(11,010)	-
Net decrease in investment in associates	-	-	26,138
B. Net Cash Provided by Investing Activities (sum of above rows)	(672,814)	(7,710,082)	(3,077,601)
CASH FLOWS FROM FINANCING ACTIVITIES			
Proceeds from:			
Long-term debt	29,021,785	10,742,004	10,627,665
Short-term debt	1,943,995	1,813,037	2,455,720
Others, specify:			
Payments of:			
Long-term debt	(18,938,899)	(7,230,103)	(8,114,551)
Dividends paid to equity holders of DMCI Holdings, Inc	(10,895,773)	(3,186,593)	(2,627,009)
Dividends paid to non-controlling interests	(1,870,654)	(1,870,178)	(1,575,702)
Interest	(735,102)	(1,127,043)	(1,037,271)
Short-term debt	(457,670)	(2,669,848)	(1,720,312)
Others, specify (negative entry):			
Increase (decrease) in:			
Payable to related parties	(27,223)	(89,249)	(190,387)
Other noncurrent liabilities	164,692	174,985	562,351
Redemption of preferred shares	-	-	(600)
C. Net Cash Used in Financing Activities (sum of above rows)	(1,794,849)	(3,442,988)	(1,620,096)
D. Effects of Exchange Rate Changes on Cash and Cash Equivalents	(1,781)	(103,274)	4,757
NET INCREASE IN CASH AND CASH EQUIVALENTS (A + B + C + D)	15,057,453	(5,332,806)	5,103,182
Cash and Cash Equivalents			
Beginning of year	9,717,042	15,049,848	9,946,666
End of year	24,774,495	9,717,042	15,049,848

NOTE: Pursuant to SRC Rule 68.1 (as amended in Nov. 2005), for fiscal years ending December 31, 2005 up to November 30, 2006, a comparative format of only two (2) years may be filed to give temporary relief for covered companies as the more complex PFRSs will be applied for the first time in these year end periods. After these first time applications, the requirement of three (3) year comparatives shall resume for year end reports beginning December 31, 2006 and onwards.

SPECIAL FORM FOR FINANCIAL STATEMENTS OF PUBLICLY-HELD AND INVESTMENT COMPANIES

NAME OF CORPORATION: DMCI HOLDINGS, INC. AND SUBSIDIARIES (Consolidated)

CURRENT ADDRESS: 2281 Don Chino Roces Avenue, Makati City

TEL. NO.: 888-3000

FAX NO.:

COMPANY TYPE: HOLDING COMPANY

PSIC:

PSIC:

PSIC:

If these are based on consolidated financial statements, please so indicate in the caption.

Table 4. Statement of Changes in Equity

FINANCIAL DATA	(Amount in P000)										
	Capital Stock	Additional Paid-in Capital	Unappropriated Retained Earnings	Appropriated Retained Earnings	Premium on Acquisition of Non-controlling Interest	Remeasurements on Retirement Plans	Net Accumulated Gains (Loss) on Available-for-Sale Financial Assets	Cumulative Translation Adjustment	TOTAL	Attributable to Non-controlling Interests	TOTAL
A. Balance, 2010	2,655,498	4,765,917	19,693,115	-	(161,033)	-	(2,781)	-	26,950,716	5,472,486	32,423,202
A.1 Effect of adoption of the Revised PAS 19	-	-	483,343	-	-	-	-	-	483,343	(5,360)	477,983
B. Restated Balance	2,655,498	4,765,917	20,176,458	-	(161,033)	-	(2,781)	-	27,434,059	5,467,126	32,901,185
C. Surplus	-	-	-	-	-	-	-	-	-	-	-
C.1 Surplus (Deficit) on Revaluation of Properties	-	-	-	-	-	-	-	-	-	-	-
C.2 Surplus (Deficit) on Revaluation of Investments	-	-	-	-	-	-	-	-	-	-	-
C.3 Currency Translation Differences	-	-	-	-	-	-	-	-	-	-	-
C.4 Other Surplus (specify)	-	-	-	-	-	-	-	-	-	-	-
D. Net Income (Loss) for the Period	-	-	9,562,954	-	-	-	-	-	9,562,954	2,681,735	12,244,689
D.1 Net income, as previously reported	-	-	9,595,451	-	-	-	-	-	9,595,451	2,681,455	12,276,906
D.2 Effect of adoption of the Revised PAS 19	-	-	(32,497)	-	-	-	-	-	(32,497)	280	(32,217)
E. Dividends (negative entry)	-	-	(2,655,494)	-	-	-	-	-	(2,655,494)	(1,575,702)	(4,231,196)
F. Appropriation for (specify)	-	-	(3,000,000)	3,000,000	-	-	-	-	-	-	-
F.1 Capacity expansion and additional investment	-	-	(3,000,000)	3,000,000	-	-	-	-	-	-	-
G. Issuance of Capital Stock	-	-	-	-	-	-	-	-	-	-	-
G.1 Common Stock	-	-	-	-	-	-	-	-	-	-	-
G.2 Preferred Stock	-	-	-	-	-	-	-	-	-	-	-
G.3 Others	-	-	-	-	-	-	-	-	-	-	-
H. Others	-	(600)	-	-	-	153,801	1,691	-	154,892	(905)	153,987
H.1 Effect of adoption of the Revised PAS 19	-	-	-	-	-	153,801	-	-	153,801	(905)	152,896
H.2 Changes in fair values of AFS financial assets	-	-	-	-	-	-	1,691	-	1,691	-	1,691
H.3 Redemption of preferred shares	-	(600)	-	-	-	-	-	-	(600)	-	(600)
I. Balance, 2011	2,655,498	4,765,317	24,083,918	3,000,000	(161,033)	153,801	(1,090)	-	34,496,411	6,572,254	41,068,665
J. Restated Balance	2,655,498	4,765,317	24,083,918	3,000,000	(161,033)	153,801	(1,090)	-	34,496,411	6,572,254	41,068,665
J.1 Balances, as previously reported	2,655,498	4,765,317	23,633,072	3,000,000	(161,033)	-	(1,090)	-	33,891,764	6,578,239	40,470,003
J.2 Effect of adoption of the Revised PAS 19	-	-	450,846	-	-	153,801	-	-	604,647	(5,985)	598,662
K. Surplus	-	-	-	-	-	-	-	-	-	-	-
K.1 Surplus (Deficit) on Revaluation of Properties	-	-	-	-	-	-	-	-	-	-	-
K.2 Surplus (Deficit) on Revaluation of Investments	-	-	-	-	-	-	-	-	-	-	-
K.3 Currency Translation Differences	-	-	-	-	-	-	-	-	-	-	-
K.4 Other Surplus (specify)	-	-	-	-	-	-	-	-	-	-	-
L. Net Income (Loss) for the Period	-	-	9,735,834	-	-	-	-	-	9,735,834	2,756,421	12,492,255
L.1 Net income, as previously reported	-	-	9,791,615	-	-	-	-	-	9,791,615	2,756,111	12,547,726
L.2 Effect of adoption of the Revised PAS 19	-	-	(55,781)	-	-	-	-	-	(55,781)	310	(55,471)
M. Dividends (negative entry)	-	-	(3,186,593)	-	-	-	-	-	(3,186,593)	(1,870,178)	(5,056,771)
N. Appropriation for (specify)	-	-	(1,600,000)	1,600,000	-	-	-	-	-	-	-
N.1 Capacity expansion and additional investment	-	-	(1,600,000)	1,600,000	-	-	-	-	-	-	-
P. Issuance of Capital Stock	-	-	-	-	-	-	-	-	-	-	-
P.1 Common Stock	-	-	-	-	-	-	-	-	-	-	-
P.2 Preferred Stock	-	-	-	-	-	-	-	-	-	-	-
P.3 Others	-	-	-	-	-	-	-	-	-	-	-
Q. Others	-	-	-	-	-	229,331	30,000	-	259,331	(7,388)	251,943
Q.1 Effect of adoption of the Revised PAS 19	-	-	-	-	-	229,331	-	-	229,331	(7,388)	221,943
Q.2 Changes in fair values of AFS financial assets	-	-	-	-	-	-	30,000	-	30,000	-	30,000
R. Balance, 2012	2,655,498	4,765,317	29,033,159	4,600,000	(161,033)	383,132	28,910	-	41,304,983	7,451,109	48,756,092
S. Restated Balance	2,655,498	4,765,317	29,033,159	4,600,000	(161,033)	383,132	28,910	-	41,304,983	7,451,109	48,756,092
S.1 Balances, as previously reported	2,655,498	4,765,317	28,638,094	4,600,000	(161,033)	-	28,910	-	40,526,786	7,464,172	47,990,958
S.2 Effect of adoption of the Revised PAS 19	-	-	395,065	-	-	383,132	-	-	778,197	(13,063)	765,134
T. Comprehensive Income	-	-	18,937,380	-	-	133,543	(22,080)	(32,376)	19,016,467	3,329,852	22,346,319
T.1 Net Income (Loss) for the Period	-	-	18,937,380	-	-	-	-	-	18,937,380	3,319,379	22,256,759
T.2 Other Comprehensive Income	-	-	-	-	-	133,543	(22,080)	(32,376)	79,087	10,473	89,560
U. Dividends (negative entry)	-	-	(9,028,680)	-	-	-	-	-	(9,028,680)	(1,870,654)	(10,899,334)
V. Appropriation for (specify)	-	-	2,500,000	(2,500,000)	-	-	-	-	-	-	-
V.1 Capacity expansion and additional investment	-	-	(1,300,000)	1,300,000	-	-	-	-	-	-	-
V.2 Reversal of appropriation	-	-	3,800,000	(3,800,000)	-	-	-	-	-	-	-
W. Balance, 2013	2,655,498	4,765,317	41,441,859	2,100,000	(161,033)	516,675	6,830	(32,376)	51,292,770	8,910,307	60,203,077

COVER SHEET

A S 0 9 5 - 0 0 2 2 8 3

SEC Registration Number

D M C I H O L D I N G S , I N C . A N D S U B S I D I A R
I E S

(Company's Full Name)

3 r d F l o o r , D a c o n B u i l d i n g , 2 2 8 1 D
o n C h i n o R o c e s A v e n u e , M a k a t i C i t
y

(Business Address: No. Street City/Town/Province)

Herbert M. Consunji
(Contact Person)

888-3000
(Company Telephone Number)

1 2 3 1
Month Day
(Fiscal Year)

A A F S
(Form Type)

Month Day
(Annual Meeting)

(Secondary License Type, If Applicable)

Dept. Requiring this Doc.

Amended Articles Number/Section

Total No. of Stockholders

Total Amount of Borrowings

Domestic

Foreign

To be accomplished by SEC Personnel concerned

File Number

_____ LCU

Document ID

_____ Cashier

S T A M P S

Remarks: Please use BLACK ink for scanning purposes.



INDEPENDENT AUDITORS' REPORT

The Stockholders and the Board of Directors
DMCI Holdings, Inc.
3rd Floor, Dacon Building
2281 Don Chino Roces Avenue
Makati City

We have audited the accompanying consolidated financial statements of DMCI Holdings, Inc. and Subsidiaries, which comprise the consolidated statements of financial position as at December 31, 2013 and 2012, and the consolidated statements of income, statements of comprehensive income, statements of changes in equity and statements of cash flows for each of the three years in the period ended December 31, 2013, and a summary of significant accounting policies and other explanatory information.

Management's Responsibility for the Consolidated Financial Statements

Management is responsible for the preparation and fair presentation of these consolidated financial statements in accordance with Philippine Financial Reporting Standards, and for such internal control as management determines is necessary to enable the preparation of consolidated financial statements that are free from material misstatement, whether due to fraud or error.

Auditors' Responsibility

Our responsibility is to express an opinion on these consolidated financial statements based on our audits. We conducted our audits in accordance with Philippine Standards on Auditing. Those standards require that we comply with ethical requirements and plan and perform the audit to obtain reasonable assurance about whether the consolidated financial statements are free from material misstatement.

An audit involves performing procedures to obtain audit evidence about the amounts and disclosures in the consolidated financial statements. The procedures selected depend on the auditor's judgment, including the assessment of the risks of material misstatement of the consolidated financial statements, whether due to fraud or error. In making those risk assessments, the auditor considers internal control relevant to the entity's preparation and fair presentation of the consolidated financial statements in order to design audit procedures that are appropriate in the circumstances, but not for the purpose of expressing an opinion on the effectiveness of the entity's internal control. An audit also includes evaluating the appropriateness of accounting policies used and the reasonableness of accounting estimates made by management, as well as evaluating the overall presentation of the consolidated financial statements.

We believe that the audit evidence we have obtained is sufficient and appropriate to provide a basis for our audit opinion.



Opinion

In our opinion, the consolidated financial statements present fairly, in all material respects, the financial position of DMCI Holdings, Inc. and Subsidiaries as at December 31, 2013 and 2012, and their financial performance and their cash flows for each of the three years in the period ended December 31, 2013 in accordance with Philippine Financial Reporting Standards.

SYCIP GORRES VELAYO & CO.

Cyril Jasmin B. Valencia
Cyril Jasmin B. Valencia
Partner
CPA Certificate No. 90787
SEC Accreditation No. 1229-A (Group A),
May 31, 2012, valid until May 30, 2015
Tax Identification No. 162-410-623
BIR Accreditation No. 08-001998-74-2012,
April 11, 2012, valid until April 10, 2015
PTR No. 4225226, January 2, 2014, Makati City

April 3, 2014



DMCI HOLDINGS, INC. AND SUBSIDIARIES
CONSOLIDATED STATEMENTS OF FINANCIAL POSITION
(Amounts in Thousands)

	December 31, 2013	December 31, 2012 (As restated - Note 2)	January 1, 2012 (As restated - Note 2)
ASSETS			
Current Assets			
Cash and cash equivalents (Notes 4 and 36)	₱24,774,495	₱9,717,042	₱15,049,848
Financial assets at fair value through profit or loss (Notes 5 and 36)	73,150	71,260	71,400
Available-for-sale financial assets (Notes 6 and 36)	59,979	88,553	59,910
Receivables - net (Notes 7, 21 and 36)	14,961,082	11,435,341	8,384,769
Costs and estimated earnings in excess of billings on uncompleted contracts (Note 8)	986,359	919,932	411,075
Inventories (Note 9)	23,171,833	21,515,161	17,484,675
Other current assets (Note 10)	7,158,892	5,478,365	4,550,946
Total Current Assets	71,185,790	49,225,654	46,012,623
Noncurrent Assets			
Noncurrent receivables (Notes 7 and 36)	5,186,785	5,242,743	2,438,697
Available-for-sale financial assets (Notes 6 and 36)	950	-	164,507
Investments in associates, jointly controlled entities and others (Note 11)	11,883,288	14,369,254	10,868,642
Investment properties (Note 12)	270,175	276,447	142,159
Property, plant and equipment (Note 13)	31,271,246	25,724,232	23,417,603
Deferred tax assets - net (Note 29)	197,599	23,218	20,744
Pension assets (Note 23)	796,723	684,791	518,021
Other noncurrent assets (Note 14)	2,958,203	1,437,747	1,046,325
Total Noncurrent Assets	52,564,969	47,758,432	38,616,698
	₱123,750,759	₱96,984,086	₱84,629,321

LIABILITIES AND EQUITY

Current Liabilities

Short-term debt (Notes 15 and 36)	₱2,119,296	₱632,971	₱1,490,648
Current portion of liabilities for purchased land (Notes 16 and 36)	885,088	929,379	471,886
Accounts and other payables (Notes 17 and 36)	13,764,063	12,300,693	11,908,718
Billings in excess of costs and estimated earnings on uncompleted contracts (Note 8)	3,680,765	3,332,565	750,744
Customers' advances and deposits (Note 18)	4,929,701	3,355,895	3,610,586
Current portion of long-term debt (Notes 19 and 36)	3,386,257	6,642,262	3,813,948
Income tax payable	66,182	89,442	138,199
Payable to related parties (Notes 21 and 36)	33,992	61,215	301,372
Total Current Liabilities	28,865,344	27,344,422	22,486,101

(Forward)



	December 31	January 1
	2012	2012
2013	(As restated - Note 2)	(As restated - Note 2)
Noncurrent Liabilities		
Long-term debt - net of current portion (Notes 19 and 36)	₱31,258,586	₱18,190,853
Liabilities for purchased land - net of current portion (Notes 16 and 36)	487,389	215,945
Deferred tax liabilities - net (Note 29)	1,149,384	862,770
Pension liabilities (Note 23)	93,765	86,349
Other noncurrent liabilities (Notes 20 and 36)	1,693,214	1,527,655
Total Noncurrent Liabilities	34,682,338	20,883,572
Total Liabilities	63,547,682	43,560,656
Equity (Note 22)		
Equity attributable to equity holders of the Parent Company:		
Paid-in capital	7,420,815	7,420,815
Retained earnings		
Appropriated	2,100,000	4,600,000
Unappropriated	41,441,859	29,033,159
Premium on acquisition of non-controlling interests	(161,033)	(161,033)
Remeasurements on retirement plans - net of tax (Note 2)	516,675	383,132
Net accumulated unrealized gains (losses) on AFS financial assets	6,830	28,910
Cumulative translation adjustment (Note 34)	(32,376)	-
Total Equity	51,292,770	41,304,983
Non-controlling interests	8,910,307	7,451,109
Total Equity	60,203,077	41,068,665
Total Equity	₱123,750,759	₱96,984,086
Total Liabilities	₱123,750,759	₱84,629,321

See accompanying Notes to Consolidated Financial Statements.



DMCI HOLDINGS, INC. AND SUBSIDIARIES
CONSOLIDATED STATEMENTS OF INCOME
(Amounts in Thousands, except for Earnings Per Share figures)

	Years Ended December 31		
	2013	2012 (As restated - Note 2)	2011 (As restated - Note 2)
REVENUE			
Electricity sales	₱16,606,674	₱11,079,789	₱10,420,559
Construction contracts	14,112,676	14,773,250	10,277,235
Mining	12,838,466	16,373,200	18,682,228
Real estate sales	12,165,988	9,219,331	8,251,128
Merchandise sales and others	246,826	294,309	171,435
	55,970,630	51,739,879	47,802,585
COSTS OF SALES AND SERVICES (Note 24)			
Electricity sales	6,453,641	5,659,928	7,019,858
Construction contracts	11,943,602	13,029,949	8,629,612
Mining	9,003,795	11,286,097	11,566,728
Real estate sales	6,670,706	4,434,929	4,080,030
Merchandise sales and others	153,224	169,733	132,752
	34,224,968	34,580,636	31,428,980
GROSS PROFIT	21,745,662	17,159,243	16,373,605
OPERATING EXPENSES (Note 25)	8,591,332	5,947,305	5,239,609
	13,154,330	11,211,938	11,133,996
OTHER INCOME (EXPENSES)			
Gain on sale of investment (Note 11)	9,157,413	-	-
Equity in net earnings of associates (Note 11)	1,802,251	2,317,551	2,185,553
Finance income (Note 26)	658,777	849,465	1,097,703
Finance costs (Note 27)	(929,328)	(1,198,528)	(1,261,885)
Other income - net (Note 28)	517,966	786,383	432,873
INCOME BEFORE INCOME TAX	24,361,409	13,966,809	13,588,240
PROVISION FOR INCOME TAX (Note 29)	2,104,650	1,474,554	1,343,551
NET INCOME (Note 35)	₱22,256,759	₱12,492,255	₱12,244,689
NET INCOME ATTRIBUTABLE TO			
Equity holders of the Parent Company	₱18,937,380	₱9,735,834	₱9,562,954
Non-controlling interests	3,319,379	2,756,421	2,681,735
	₱22,256,759	₱12,492,255	₱12,244,689
EARNINGS PER SHARE ATTRIBUTABLE TO EQUITY HOLDERS OF THE PARENT COMPANY-BASIC AND DILUTED (Note 30)			
	₱7.13	₱3.67	₱3.60

See accompanying Notes to Consolidated Financial Statements.



DMCI HOLDINGS, INC. AND SUBSIDIARIES
CONSOLIDATED STATEMENTS OF COMPREHENSIVE INCOME
(Amounts in Thousands)

	Years Ended December 31		
	2013	2012 (As restated - Note 2)	2011 (As restated - Note 2)
NET INCOME	₱22,256,759	₱12,492,255	₱12,244,689
OTHER COMPREHENSIVE INCOME (LOSS)			
Items to be reclassified subsequently to profit or loss			
Cumulative translation adjustment (Note 34)	(32,376)	-	-
Changes in fair values of AFS financial assets (Note 6)	(22,016)	30,000	1,691
	(54,392)	30,000	1,691
Items not to be reclassified to profit or loss in subsequent periods			
Remeasurement gains on retirement plans (Note 23)	164,272	237,384	166,533
Income tax effect	(20,320)	(15,441)	(13,637)
	143,952	221,943	152,896
OTHER COMPREHENSIVE INCOME	89,560	251,943	154,587
TOTAL COMPREHENSIVE INCOME	₱22,346,319	₱12,744,198	₱12,399,276
TOTAL COMPREHENSIVE INCOME ATTRIBUTABLE TO:			
Equity holders of the Parent Company	₱19,016,467	₱9,995,165	₱9,718,446
Non-controlling interests	3,329,852	2,749,033	2,680,830
	₱22,346,319	₱12,744,198	₱12,399,276

See accompanying Notes to Consolidated Financial Statements.



DMCI HOLDINGS, INC. AND SUBSIDIARIES
CONSOLIDATED STATEMENTS OF CHANGES IN EQUITY
(Amounts in Thousands)

	Attributable to Equity Holders of the Parent Company											
	Capital Stock (Note 22)	Additional Paid-in Capital (Note 22)	Total Paid-in Capital (Note 22)	Unappropriated Retained Earnings (Note 22)	Appropriated Retained Earnings (Note 22)	Premium on Acquisition of Non- controlling Interest	Remeasurements on Retirement Plans (Note 2)	Net Accumulated Gain (Loss) on Available-for- Sale Financial Assets (Note 6)	Cumulative Translation Adjustment (Note 34)	Total	Non-controlling Interests (Note 22)	Total Equity
For the Year Ended December 31, 2013												
Balances as of January 1, 2013, as previously reported	₱2,655,498	₱4,765,317	₱7,420,815	₱28,638,094	₱4,600,000	(₱161,033)	₱-	₱28,910	₱-	₱40,526,786	₱7,464,172	₱47,990,958
Effect of adoption of the Revised PAS 19 (Note 2)	-	-	-	395,065	-	-	383,132	-	-	778,197	(13,063)	765,134
Balances as of January 1, 2013, as restated	2,655,498	4,765,317	7,420,815	29,033,159	4,600,000	(161,033)	383,132	28,910	-	41,304,983	7,451,109	48,756,092
Comprehensive income												
Net income	-	-	-	18,937,380	-	-	-	-	-	18,937,380	3,319,379	22,256,759
Other comprehensive income	-	-	-	-	-	-	133,543	(22,080)	(32,376)	79,087	10,473	89,560
Total comprehensive income	-	-	-	18,937,380	-	-	133,543	(22,080)	(32,376)	19,016,467	3,329,852	22,346,319
Reversal of appropriation	-	-	-	3,800,000	(3,800,000)	-	-	-	-	-	-	-
Appropriation	-	-	-	(1,300,000)	1,300,000	-	-	-	-	-	-	-
Dividends declared	-	-	-	(9,028,680)	-	-	-	-	-	(9,028,680)	(1,870,654)	(10,899,334)
Balances at December 31, 2013	₱2,655,498	₱4,765,317	₱7,420,815	₱41,441,859	₱2,100,000	(₱161,033)	₱516,675	₱6,830	(₱32,376)	₱51,292,770	₱8,910,307	₱60,203,077
For the Year Ended December 31, 2012												
Balances as of January 1, 2012, as previously reported	₱2,655,498	₱4,765,317	₱7,420,815	₱23,633,072	₱3,000,000	(₱161,033)	₱-	(₱1,090)	₱-	₱33,891,764	₱6,578,239	₱40,470,003
Effect of adoption of the Revised PAS 19 (Note 2)	-	-	-	450,846	-	-	153,801	-	-	604,647	(5,985)	598,662
Balances as of January 1, 2012, as restated	2,655,498	4,765,317	7,420,815	24,083,918	3,000,000	(161,033)	153,801	(1,090)	-	34,496,411	6,572,254	41,068,665
Comprehensive income												
Net income, as previously reported	-	-	-	9,791,615	-	-	-	-	-	9,791,615	2,756,111	12,547,726
Effect of adoption of the Revised PAS 19 (Note 2)	-	-	-	(55,781)	-	-	-	-	-	(55,781)	310	(55,471)
Net income, as restated	-	-	-	9,735,834	-	-	-	-	-	9,735,834	2,756,421	12,492,255
Other comprehensive income, as previously reported	-	-	-	-	-	-	-	30,000	-	30,000	-	30,000
Effect of adoption of the Revised PAS 19 (Note 2)	-	-	-	-	-	-	229,331	-	-	229,331	(7,388)	221,943
Other comprehensive income, as restated	-	-	-	-	-	-	229,331	30,000	-	259,331	(7,388)	251,943
Total comprehensive income, as restated	-	-	-	9,735,834	-	-	229,331	30,000	-	9,995,165	2,749,033	12,744,198
Appropriation	-	-	-	(1,600,000)	1,600,000	-	-	-	-	-	-	-
Dividends declared	-	-	-	(3,186,593)	-	-	-	-	-	(3,186,593)	(1,870,178)	(5,056,771)
Balances at December 31, 2012, as restated	₱2,655,498	₱4,765,317	₱7,420,815	₱29,033,159	₱4,600,000	(₱161,033)	₱383,132	₱28,910	₱-	₱41,304,983	₱7,451,109	₱48,756,092



Attributable to Equity Holders of the Parent Company

	Capital Stock (Note 22)	Additional Paid-in Capital (Note 22)	Total Paid-in Capital (Note 22)	Unappropriated Retained Earnings (Note 22)	Appropriated Retained Earnings (Note 22)	Premium on Acquisition of Non- controlling Interest	Remeasurements on Retirement Plans (Note 2)	Net Accumulated Gains (Loss) on Available-for- Sale Financial Assets (Note 6)	Cumulative Translation Adjustment (Note 34)	Total	Non-controlling Interests (Note 22)	Total Equity
For the Year Ended December 31, 2011												
Balances as of January 1, 2011, as previously reported	₱2,655,498	₱4,765,917	₱7,421,415	₱19,693,115	₱-	(₱161,033)	₱-	(₱2,781)	₱-	₱26,950,716	₱5,472,486	₱32,423,202
Effect of adoption of the Revised PAS 19 (Note 2)	-	-	-	483,343	-	-	-	-	-	483,343	(5,360)	477,983
Balances as of January 1, 2011, as restated	2,655,498	4,765,917	7,421,415	20,176,458	-	(161,033)	-	(2,781)	-	27,434,059	5,467,126	32,901,185
Comprehensive income												
Net income, as previously reported	-	-	-	9,595,451	-	-	-	-	-	9,595,451	2,681,455	12,276,906
Effect of adoption of the Revised PAS 19 (Note 2)	-	-	-	(32,497)	-	-	-	-	-	(32,497)	280	(32,217)
Net income, as restated	-	-	-	9,562,954	-	-	-	-	-	9,562,954	2,681,735	12,244,689
Other comprehensive income, as previously reported	-	-	-	-	-	-	-	1,691	-	1,691	-	1,691
Effect of adoption of the Revised PAS 19 (Note 2)	-	-	-	-	-	-	153,801	-	-	153,801	(905)	152,896
Other comprehensive income, as restated	-	-	-	-	-	-	153,801	1,691	-	155,492	(905)	154,587
Total comprehensive income, as restated	-	-	-	9,562,954	-	-	153,801	1,691	-	9,718,446	2,680,830	12,399,276
Appropriation	-	-	-	(3,000,000)	3,000,000	-	-	-	-	-	-	-
Dividends declared	-	-	-	(2,655,494)	-	-	-	-	-	(2,655,494)	(1,575,702)	(4,231,196)
Redemption of preferred shares	-	(600)	(600)	-	-	-	-	-	-	(600)	-	(600)
Balances at December 31, 2011, as restated	₱2,655,498	₱4,765,317	₱7,420,815	₱24,083,918	₱3,000,000	(₱161,033)	₱153,801	(₱1,090)	₱-	₱34,496,411	₱6,572,254	₱41,068,665

See accompanying Notes to Consolidated Financial Statements.



DMCI HOLDINGS, INC. AND SUBSIDIARIES
CONSOLIDATED STATEMENTS OF CASH FLOWS
(Amounts in Thousands)

	Years Ended December 31		
	2013	2012 (As restated - Note 2)	2011 (As restated - Note 2)
CASH FLOWS FROM OPERATING ACTIVITIES			
Income before income tax	₱24,361,409	₱13,966,809	₱13,588,240
Adjustments for:			
Depreciation, depletion and amortization (Notes 12, 13, 14, 24 and 25)	4,186,062	3,329,842	3,093,843
Finance costs (Note 27)	929,328	1,198,528	1,261,885
Provisions for doubtful accounts (Note 25)	443,650	78,296	15,178
Loss on PPE writedown (Note 28)	443,349	341,146	-
Movement in net retirement asset	39,438	(156,320)	
Writedown on investments in jointly controlled entities (Note 11)	409	-	
Gain on sale of investments (Note 11)	(9,157,413)	-	-
Equity in net earnings of associates and jointly controlled entity (Note 11)	(1,802,251)	(2,317,551)	(2,185,199)
Finance income (Note 26)	(658,777)	(849,864)	(1,097,703)
Net unrealized foreign exchange loss (gain)	(203,482)	(182,518)	18,974
Gain on sale property, plant and equipment (Note 28)	(144,855)	(127,497)	(57,565)
Reversal of impairment on other noncurrent assets (Note 14)	(61,549)	-	-
Gain on bargain purchase (Note 33)	(31,041)	-	-
Dividend income (Notes 11 and 28)	(4,291)	(25,379)	(4,547)
Unrealized market loss (gain) on financial assets at FVPL (Note 5)	(1,890)	140	(1,400)
Impairment of noncurrent assets (Note 14)	-	47,150	-
Loss on sale of available-for-sale financial assets (Note 6)	-	986	-
Gain on reversal of impairment on PPE (Note 28)	-	-	(6,670)
Operating income before changes in working capital	18,338,096	15,303,768	14,625,036
Decrease (increase) in:			
Costs and estimated earnings in excess of billings on uncompleted contracts	(66,427)	329,347	(2,888)
Receivables	(1,794,532)	(5,652,933)	1,116,236
Inventories	(535,209)	(3,179,438)	(5,642,985)
Other current assets	(1,678,720)	(931,039)	(698,297)

(Forward)



Years Ended December 31			
	2013	2012 (As restated - Note 2)	2011 (As restated - Note 2)
Increase (decrease) in:			
Customers' advances and deposits	₱1,573,806	₱1,619,541	(₱799,490)
Accounts and other payables	2,799,891	(217,989)	1,516,671
Liabilities for purchased land	217,979	217,979	(498,574)
Billings in excess of costs and estimated earnings on uncompleted contracts	348,200	(395,497)	163,864
Cash generated from operations	19,203,084	7,093,739	9,779,573
Interest received	325,147	852,289	1,080,363
Income taxes paid	(1,328,752)	(1,709,150)	(849,894)
Interest paid and capitalized as cost of inventory (Note 19)	(672,582)	(313,340)	(213,920)
Net cash provided by operating activities	17,526,897	5,923,538	9,796,122
CASH FLOWS FROM INVESTING ACTIVITIES			
Additions to:			
Investment in financial asset at FVPL (Note 5)	-	-	(70,000)
Property, plant and equipment (Notes 3 and 13)	(10,247,891)	(6,165,489)	(3,539,342)
Investments in associates, jointly controlled entity and others (Note 11)	(1,029,334)	-	(1,300)
Investment properties (Note 12)	(25,939)	(139,197)	(32,138)
Available-for-sale financial assets (Note 6)	-	-	(7,105)
Proceeds from disposals of:			
Investments in associates, jointly controlled entity and others (Note 11)	8,227,483	-	-
Property and equipment	381,556	136,040	76,077
Available-for-sale financial assets (Note 6)	-	164,878	150
Dividends received	5,225,306	881,507	703,198
Increase in other noncurrent assets	(1,480,444)	-	(233,279)
Acquisition of a business - net of cash acquired (Note 11)	(1,622,171)	(2,576,811)	-
Interest paid and capitalized as cost of property, plant and equipment	(101,380)	(11,010)	-
Net decrease in investment in associates	-	-	26,138
Net cash used in investing activities	(672,814)	(7,710,082)	(3,077,601)
CASH FLOWS FROM FINANCING ACTIVITIES			
Proceeds from:			
Long-term debt	29,021,785	10,742,004	10,627,665
Short-term debt	1,943,995	1,813,037	2,455,720
Payments of:			
Long-term debt	(18,938,899)	(7,230,103)	(8,114,551)

(Forward)



	Years Ended December 31		
	2013	2012	2011
Dividends paid to equity holders of DMCI Holdings, Inc.	(₱10,895,773)	(₱3,186,593)	(₱2,627,009)
Dividends paid to non-controlling interests (Note 22)	(1,870,654)	(1,870,178)	(1,575,702)
Interest	(735,102)	(1,127,043)	(1,037,271)
Short-term debt	(457,670)	(2,669,848)	(1,720,312)
Increase (decrease) in:			
Payable to related parties (Note 21)	(27,223)	(89,249)	(190,387)
Other noncurrent liabilities	164,692	174,985	562,351
Redemption of preferred shares	-	-	(600)
Net cash used in financing activities	(1,794,849)	(3,442,988)	(1,620,096)
EFFECT OF EXCHANGE RATE CHANGES ON CASH AND CASH EQUIVALENTS	(1,781)	(103,274)	4,757
NET INCREASE (DECREASE) IN CASH AND CASH EQUIVALENTS	15,057,453	(5,332,806)	5,103,182
CASH AND CASH EQUIVALENTS AT BEGINNING OF YEAR	9,717,042	15,049,848	9,946,666
CASH AND CASH EQUIVALENTS AT END OF YEAR (Note 4)	₱24,774,495	₱9,717,042	₱15,049,848

See accompanying Notes to Consolidated Financial Statements.



DMCI HOLDINGS, INC. AND SUBSIDIARIES

NOTES TO CONSOLIDATED FINANCIAL STATEMENTS

1. Corporate Information

DMCI Holdings, Inc. (the Parent Company) was incorporated on March 8, 1995 and is domiciled in the Philippines. The Parent Company's registered office address and principal place of business is at 3rd Floor, Dacon Building, 2281 Don Chino Roces Avenue, Makati City.

The Parent Company is the holding company of the DMCI Group (collectively referred to herein as the Group), which is primarily engaged in general construction, mining, power generation, infrastructure, real estate development, water concessionaire and manufacturing.

The Parent Company's shares of stock are listed and are currently traded at the Philippine Stock Exchange (PSE).

The accompanying consolidated financial statements were approved and authorized for issue by the Board of Directors (BOD) on April 3, 2014.

2. Summary of Significant Accounting Policies

Basis of Preparation

The consolidated financial statements of the Group have been prepared using the historical cost basis, except for available-for-sale (AFS) financial assets and financial assets at fair value through profit or loss (FVPL) that have been measured at fair value. The Group's functional and presentation currency is the Philippine Peso (₱). All amounts are rounded to the nearest thousand (₱000), unless otherwise indicated.

The consolidated financial statements provide comparative information in respect of the previous period. In addition, the Group presents an additional statement of financial position at the beginning of the earliest period presented when there is a retrospective application of an accounting policy, a retrospective restatement, or a reclassification of items in financial statements. An additional statement of financial position as at January 1, 2012 is presented in these consolidated financial statements due to retrospective application of certain accounting policies.

Statement of Compliance

The consolidated financial statements of the Group have been prepared in compliance with Philippine Financial Reporting Standards (PFRS).

Basis of Consolidation

The consolidated financial statements comprise the financial statements of the Group as of December 31, 2013 and 2012, and for each of the three years in the period ended December 31, 2013.

The consolidated financial statements are prepared using uniform accounting policies for like transactions and other events in similar circumstances. All significant intercompany balances and transactions, including income, expenses and dividends, are eliminated in full. Profits and losses resulting from intercompany transactions that are recognized in assets are eliminated in full.



Control is achieved when the Group is exposed, or has rights, to variable returns from its involvement with the investee and has the ability to affect those returns through its power over the investee. Specifically, the Group controls an investee if and only if the Group has:

- Power over the investee (i.e. existing rights that give it the current ability to direct the relevant activities of the investee)
- Exposure, or rights, to variable returns from its involvement with the investee, and
- The ability to use its power over the investee to affect its returns

When the Group has less than a majority of the voting or similar rights of an investee, the Group considers all relevant facts and circumstances in assessing whether it has power over an investee, including:

- The contractual arrangement with the other vote holders of the investee
- Rights arising from other contractual arrangements
- The Group's voting rights and potential voting rights

The Group re-assesses whether or not it controls an investee if facts and circumstances indicate that there are changes to one or more of the three elements of control. Consolidation of a subsidiary begins when the Group obtains control over the subsidiary and ceases when the Group loses control of the subsidiary. Assets, liabilities, income and expenses of a subsidiary acquired or disposed of during the year are included in the statement of comprehensive income from the date the Group gains control until the date the Group ceases to control the subsidiary.

Non-controlling interests (NCI) pertain to the equity in a subsidiary not attributable, directly or indirectly to the Parent Company. NCI represent the portion of profit or loss and net assets in subsidiaries not wholly owned by the Group and are presented separately in consolidated statement of income, consolidated statement of comprehensive income and consolidated statement of changes in equity and within equity in the consolidated statement of financial position, separately from equity holders' of the Parent Company.

Any equity instruments issued by a subsidiary that are not owned by the Parent Company are non-controlling interests including preferred shares.

Profit or loss and each component of other comprehensive income (OCI) are attributed to the equity holders of the parent of the Group and to the NCI, even if this results in the NCI having a deficit balance. When necessary, adjustments are made to the financial statements of subsidiaries to bring their accounting policies into line with the Group's accounting policies. All intra-group assets and liabilities, equity, income, expenses and cash flows relating to transactions between members of the Group are eliminated in full on consolidation.

A change in the ownership interest of a subsidiary, without a loss of control, is accounted for as an equity transaction. If the Group loses control over a subsidiary, it:

- Derecognizes the assets (including goodwill) and liabilities of the subsidiary
- Derecognizes the carrying amount of any NCI
- Derecognizes the cumulative translation differences recorded in equity
- Recognizes the fair value of the consideration received
- Recognizes the fair value of any investment retained
- Recognizes any surplus or deficit in profit or loss
- Reclassifies the Parent Company's share of components previously recognised in OCI to profit or loss or retained earnings, as appropriate, as would be required if the Group had directly disposed of the related assets or liabilities



The consolidated financial statements include the financial statements of the Parent Company and the following subsidiaries (which are all incorporated in the Philippines, except for Toledo Mining Corporation which is incorporated in England and Wales under the Companies Act 1985):

	2013			2012			2011		
	Direct	Indirect	Effective Interest	Direct	Indirect	Effective Interest	Direct	Indirect	Effective Interest
	(In percentage)								
<u>General Construction:</u>									
D.M. Consunji, Inc. (DMCI) ¹	100.00	-	100.00	100.00	-	100.00	100.00	-	100.00
DMCI International, Inc. (DMCII) ²	-	-	-	-	100.00	100.00	-	100.00	100.00
OHKI-DMCI Corporation (OHKI) ²	-	-	-	-	100.00	100.00	-	100.00	100.00
DMCI-Laing Construction, Inc. (DMCI-Laing) ²	-	-	-	-	60.00	60.00	-	60.00	60.00
Beta Electric Corporation (Beta Electric) ²	-	51.77	51.77	-	51.77	51.77	-	51.77	51.77
Raco Haven Automation Philippines, Inc. (Raco) ²	-	50.14	50.14	-	50.14	50.14	-	50.14	50.14
<u>Mining:</u>									
Semirara Mining Corporation (Semirara)	56.32	-	56.32	56.32	-	56.32	56.32	-	56.32
DMCI Mining Corporation (DMC)	100.00	-	100.00	100.00	-	100.00	100.00	-	100.00
Toledo Mining Corporation (TMC) ⁶	-	98.09	98.09	-	17.01	17.01	-	-	-
<u>Real Estate Development:</u>									
DMCI Project Developers, Inc. (PDI)	88.87	11.13	100.00	88.87	11.13	100.00	88.87	11.13	100.00
Hampstead Gardens Corporation (Hampstead) ³	-	100.00	100.00	-	100.00	100.00	-	100.00	100.00
Riviera Land Corporation (Riviera) ³	-	100.00	100.00	-	100.00	100.00	-	100.00	100.00
DMCI-PDI Hotels, Inc. (PDI Hotels) ³	-	100.00	100.00	-	100.00	100.00	-	100.00	100.00
DMCI Homes Property Management Corporation (DHPMC) ³	-	100.00	100.00	-	100.00	100.00	-	100.00	100.00
<u>Manufacturing:</u>									
Semirara Cement Corporation (SemCem) *	100.00	-	100.00	100.00	-	100.00	100.00	-	100.00
Oriken Dynamix Company, Inc. (Oriken) ²	-	89.00	89.00	-	89.00	89.00	-	89.00	89.00
DMCI Technical Training Center (DMCI Training)	-	100.00	100.00	-	100.00	100.00	-	100.00	100.00

(Forward)



	2013			2012			2011		
	Direct	Indirect	Effective Interest	Direct	Indirect	Effective Interest	Direct	Indirect	Effective Interest
	(In percentage)								
Wire Rope Corporation of the Philippines (Wire Rope)	45.68	16.02	61.70	45.68	16.02	61.70	45.68	16.02	61.70
Semirara Claystone, Inc. (SCI) ^{4*}	-	56.32	56.32	-	56.32	56.32	-	-	-
<u>Marketing Arm:</u>									
DMCI Homes, Inc. (DMCI Homes) ³	-	100.00	100.00	-	100.00	100.00	-	100.00	100.00
<u>Power:</u>									
DMCI Power Corporation (DPC) (formerly DMCI Energy Resources Unlimited Inc.)	100.00	-	100.00	100.00	-	100.00	100.00	-	100.00
DMCI Masbate Power Corporation (DMCI Masbate) ⁵	-	100.00	100.00	-	100.00	100.00	-	100.00	100.00
DMCI Palawan Power Corporation (DMCI Palawan) ⁵	-	100.00	100.00	-	100.00	100.00	-	-	-
Sem-Calaca Power Corporation (SCPC) ⁴	-	56.32	56.32	-	56.32	56.32	-	56.32	56.32
Southwest Luzon Power Generation Corporation (SLPGC) ^{4*}	-	56.32	56.32	-	56.32	56.32	-	56.32	56.32
Sem-Calaca Res Corporation (SCRC) (formerly DMCI Calaca Power Corporation) ^{4*}	-	56.32	56.32	100.00	-	100.00	100.00	-	100.00
SEM-Cal Industrial Park Developers, Inc. (SIPDI) ^{4*}	-	56.32	56.32	-	56.32	56.32	-	56.32	56.32
Semirara Energy Utilities, Inc. (SEUI) ^{4*}	-	56.32	56.32	-	-	-	-	-	-
St. Raphael Power Generation Corporation (SRPGC) ^{4*}	-	56.32	56.32	-	-	-	-	-	-
SEM-Balayan Power Generation Corporation (SBPGC) ^{4*}	-	56.32	56.32	-	-	-	-	-	-

* Have not yet started commercial operations as of December 31, 2013

¹ Also engaged in real estate development

² DMCI's subsidiaries

³ PDI's subsidiaries

⁴ Semirara's subsidiaries

⁵ DPC's subsidiaries

⁶ DMC's subsidiary

General Construction

DMCI

Subscription to PDI's increase in authorized capital stock

On October 30, 2009, the PDI BOD and stockholders approved the increase in the PDI's authorized capital stock from ₱3.00 billion, divided into 3,000,000,000 common shares with a par value of ₱1.00 per share, to ₱5.00 billion, divided into 5,000,000,000 common shares with a par value of ₱1.00 per share.



On December 30, 2010, the Securities and Exchange Commission (SEC) approved PDI's application for increase in authorized capital stock. Of the said increase in the authorized capital stock of 2 billion common shares at ₱1.00 par value per share, 538,132,578 common shares have been subscribed by the DMCI and the Parent Company, each subscribing 504,862,578 shares and 33,270,000 shares, respectively in exchange of real estate properties.

On September 24, 2012, PDI filed a petition for the substitution of subscription payment to the increase of capital stock from real estate properties to cash. DMCI paid the subscription in October 2012. As at December 31, 2013, PDI is still awaiting for the SEC's approval of the above petition. Subsequently on January 9, 2014, the SEC granted the petition.

Declaration of Investment in PDI as Property Dividends to the Parent Company

In October 2011, DMCI declared majority of its investment in PDI as property dividends to the Parent Company with equivalent value of ₱949.59 million representing 30.57% share in PDI.

On December 5, 2011, the SEC approved DMCI's application to declare its investment in PDI as property dividend to the Parent Company. The property dividend amounted to ₱949.59 million payable in 949,594,750 shares of stocks in PDI with same par value. As a result, PDI became 88.87% owned by the Parent Company.

Revocation of Investees' SEC Licenses

In 2013, the Company has retired its various investments in subsidiaries and associates. The Company received the notice from the SEC approving the revocation of the investees' SEC licenses. Entities whose SEC licenses are revoked include:

- DMCI-Laing Construction, Inc.
- OHKI-DMCI Corporation
- DMCI International, Inc
- Eco Process & Equipment Philippines, Inc.

Due to the revocation, the Company derecognized the investees' respective net assets in the books with remaining total carrying value of ₱16.75 million.

Mining
DMC

DMC was incorporated and domiciled in the Republic of the Philippines on May 29, 2007 primarily to carry on the business of mining, developing, exploiting, extracting, milling, concentrating, preparing for market, manufacturing, buying, shipping and transporting, all kinds of ores, metals and minerals. It involves surface mining and direct shipping of nickel laterite ore and is conducted through simple benching operation using excavators and trucks in Sta. Cruz and Candelaria, Zambales.

On March 31, 2013, the BOD of DMC approved the acceptance of ₱1.80 billion advances from the Parent Company as deposit for future additional issuances of DMC's capital stock.

On September 24, 2013, the BOD approved the increase in the authorized capital stock of DMC from ₱0.50 billion divided into 0.50 billion shares with a par value of ₱1.00 per share to ₱5.00 billion divided into 5.00 billion shares with a par value of ₱1.00 per share.



On November 19, 2013, the Parent Company and DMC executed a Deed of Assignment of Advances wherein the BOD of DMC approved and agreed for the conversion of the advances made by the Parent Company into equity for the additional subscription to 1.80 billion shares of DMC.

On December 19, 2013, the SEC approved DMC's application for increase in its authorized capital stock. Accordingly, the advances were converted to equity and 1.80 billion shares were issued as of December 31, 2013.

TMC

In October 2012, DMC acquired 17% stake of Daintree Resources Limited in TMC for GBP 3.4 million. Such investment was accounted for as an associate as of December 31, 2012.

In 2013, DMC increased its interest in TMC by acquiring additional shares through a mandatory cash offer to TMC's shareholders representing additional 81.09% interest. As of December 31, 2013, DMC holds 49,148,335 shares and voting rights representing 98.09% of voting rights.

On December 20, 2013 after establishing the 98.09% voting rights and gaining majority seats in the BOD of TMC, DMC obtained control over TMC. TMC has subsequently delisted on London Stock Exchange – Alternative Investment Market (AIM) after the resolution for the matter has been approved on the General Meeting of Shareholders. The business combination transaction was initially accounted provisionally as allowed under PFRS 3 (see Note 33).

Power

DPC

DPC was incorporated and domiciled in the Republic of the Philippines. It was registered with the SEC on October 16, 2006 to engage in acquiring, designing, constructing, investing in and operating electric power plants, and engaging in the business of a Generation Company in accordance with Republic Act (RA) No. 9136 otherwise known as the Electric Power Industry Reform Act (EPIRA) of 2001.

On December 17, 2013, the Parent Company and DPC entered into a Subscription Agreement for the subscription of the latter's new shares. As of the date of signing the Agreement, the authorized capital stock of DPC amounts to ₱1,000.00 million, divided into 1,000.00 million shares, with a par value of ₱1.00 per share, out of which ₱300.00 million consisting of 300.00 million shares have been previously issued to the subscriber. Subject to the terms and conditions provided in the Agreement, the Parent Company subscribed to 700.00 million new shares from the unissued portion of DPC's existing authorized capital stock, at the subscription price of ₱1.00 per share, or a total of subscription price for all the new shares of ₱700.00 million.

Upon signing of the Agreement, ₱150.00 million has been paid in the subscription price. The balance of ₱550.00 million will be paid in two or more tranches upon the call of DPC's Board of Directors, provided the Subscriber is notified of such call at least three business days prior to the due date of payment.

DMCI Masbate

DMCI Masbate was incorporated and domiciled in the Republic of the Philippines. It was registered with the SEC on November 13, 2007 primarily to acquire, design, develop, construct, invest in and operate power generating plants in the province of Masbate and engage in the business of a generation company in accordance with RA No. 9136 otherwise known as the EPIRA and its implementing rules and regulations, and to design, develop, assemble and operate other power related facilities, appliances and devices.



On February 3, 2011, the Parent Company and DPC executed a Deed of Assignment, whereby the Parent Company conveyed all its rights and interest over its subscribed 5,099,995 shares of DMCI Masbate with ₱1.00 par value each, of which ₱1.28 million has been paid. As at December 31, 2011, DMCI Masbate is wholly owned by DPC.

DMCI Palawan

DMCI Palawan Power Corporation, a wholly-owned subsidiary of DPC, was incorporated and domiciled in the Republic of the Philippines. It was registered with the Securities and Exchange Commission (SEC) on September 12, 2012 primarily to acquire, design, develop, construct, invest in and operate power generating plants in the province of Palawan and engage in the business of a generation company in accordance with RA No. 9136, otherwise known as EPIRA and its implementing rules and regulations, and to design, develop, assemble and operate other power related facilities, appliances and devices.

In 2012, DPC provided equity funding to DMCI Palawan amounting ₱2.50 million.

SLPGC

On August 31, 2011, SLPGC, a wholly-owned subsidiary of Semirara, was incorporated to operate electric power plants and to engage in business of a Generation Company. In 2011, Semirara provided equity funding to SLPGC amounting ₱770.20 million.

SCRC

SCRC is a stock corporation registered with SEC on September 14, 2009, primarily to sell electricity to any person or entity through electricity markets, by trading, or by contract, to administer, conserve and manage the electricity generated by power-generating plants, owned by its affiliates or by a third party, to invest in or acquire corporations or entities engaged in any of the foregoing activities.

Prior to 2013, the Parent Company owns 100% of common shares of SCRC. However, on March 15, 2013, the Parent Company assigned all of its 1.25 million shares in SCRC to SCPC at ₱1.00 par value or in the total amount of ₱1.25 million, making it as a wholly owned subsidiary of SCPC.

On September 25, 2013, SCPC subscribed to additional 6.75 million SCRC shares bringing the total investment in SCRC to ₱8.00 million as of December 31, 2013. The related shares were issued as of December 31, 2013. The Parent Company has 56.32% indirect ownership interest in SCPC and thus, an effective ownership interest of the same in SCRC.

SIPDI

On April 24, 2011, SIPDI was incorporated to acquire, develop, construct, invest in, operate and maintain an economic zone capable of providing infrastructures and other support facilities for export manufacturing enterprises, information technology enterprises, tourism economic zone enterprises, medical tourism economic zone enterprises, retirement economic zone enterprises and/or agro-industrial enterprises, inclusive of the required facilities and utilities, such as light and power system, water supply and distribution system, sewerage and drainage system, pollution control devices, communication facilities, paved road network, and administration building as well as amenities required by professionals and workers involved in such enterprises, in accordance with R.A. No. 7916, as amended by R.A. No. 8748, otherwise known as the Special Economic Zone Act of 1995.



SEUI

On February 18, 2013, SEUI was incorporated to perform Qualified Third Party (QTP) functions pursuant to Section 59 of Republic Act 9136, otherwise known as the EPIRA and its Implementing Rules & Regulations". DOE-Circular No. 2004-06-006 of the Department of Energy defines QTP as an alternative service provider authorized to serve remote and unviable areas pursuant to Section 59 of the EPIRA Law. The new company intends to act as the QTP over Barangays of Semirara, Tinogboc and Alegria, all located at Semirara Island, Caluya, Antique.

SRPGC

On September 10, 2013, SRPGC was incorporated to acquire, construct, erect, assemble, rehabilitate, expand, commission, operate and maintain power-generating plants and related facilities for the generation of electricity, including facilities to purchase, manufacture, develop or process fuel for the generation of such electricity; to sell electricity to any person or entity through electricity markets, by trading, or by contract; to administer, conserve and manage the electricity generated by power-generating plants, owned by SRPGC or by a third party, to invest in or acquire corporations or entities engaged in any of the foregoing activities.

SBPGC

On September 9, 2013, SBPGC was incorporated to acquire, construct, erect, assemble, rehabilitate, expand, commission, operate and maintain power-generating plants and related facilities for the generation of electricity, including facilities to purchase, manufacture, develop or process fuel for the generation of such electricity, to sell electricity to any person or entity through electricity markets, by trading, or by contract, to administer, conserve and manage the electricity generated by power-generating plants, owned by SBPGC or by a third party, to invest in or acquire corporations or entities engaged in any of the foregoing activities.

Manufacturing

SCI

On November 29, 2012, SCI was incorporated to engage in, conduct, and carry on the business of manufacturing, buying, selling, distributing, marketing at wholesale and retail insofar as may be permitted by law, all kinds of goods, commodities, wares and merchandise of every kind and description including pottery earthenware, stoneware, bricks, tiles, roofs and other merchandise produce from clay; to enter into all contracts for export, import, purchase requisition, sale at wholesale or retail and other disposition for its own account as principal or in representative capacity as manufacturer's representative, merchandise broker, indenter, commission merchant, factors or agents, upon consignment of all goods, wares, merchandise or products natural or artificial. In 2012, Semirara provided equity funding to SCI amounting ₱2.50 million.

DMCI Training

DMCI Training was registered with SEC on August 15, 2006. The primary purpose of the company is to establish, promote, and operate training centers and or institutions in the field of science, technology, vocational and other apprenticeable trades and occupations in which qualified and deserving persons regardless of gender may be thought, developed and trained in a well-rounded theoretical and practical method.

Changes in Accounting Policies and Disclosures

The Group applied, for the first time, certain standards and amendments that require restatement of previous financial statements. These include PFRS 10, *Consolidated Financial Statements*, PFRS 11, *Joint Arrangements*, Philippine Accounting Standards (PAS) 19, *Employee Benefits*



(Revised 2011), PFRS 13, *Fair Value Measurement* and amendments to PAS 1, *Presentation of Financial Statements*. In addition, the application of PFRS 12, *Disclosure of Interests in Other Entities*, resulted in additional disclosures in the consolidated financial statements.

Several other amendments apply for the first time in 2013. However, they do not impact the annual consolidated financial statements of the Group.

The nature and the impact of each new standard and amendment are described below:

- PFRS 7, *Financial instruments: Disclosures - Offsetting Financial Assets and Financial Liabilities* (Amendments)
These amendments require an entity to disclose information about rights of set-off and related arrangements (such as collateral agreements). The new disclosures are required for all recognized financial instruments that are set off in accordance with PAS 32, *Financial Instruments: Presentation - Offsetting Financial Assets and Financial Liabilities* (Amendments). These disclosures also apply to recognized financial instruments that are subject to an enforceable master netting arrangement or 'similar agreement', irrespective of whether they are set-off in accordance with PAS 32. The amendments require entities to disclose, in a tabular format, unless another format is more appropriate, the following minimum quantitative information. This is presented separately for financial assets and financial liabilities recognized at the end of the reporting period:
 - a) The gross amounts of those recognized financial assets and recognized financial liabilities;
 - b) The amounts that are set off in accordance with the criteria in PAS 32 when determining the net amounts presented in the statement of financial position;
 - c) The net amounts presented in the statement of financial position;
 - d) The amounts subject to an enforceable master netting arrangement or similar agreement that are not otherwise included in (b) above, including:
 - i. Amounts related to recognized financial instruments that do not meet some or all of the offsetting criteria in PAS 32; and
 - ii. Amounts related to financial collateral (including cash collateral); and
 - e) The net amount after deducting the amounts in (d) from the amounts in (c) above.

The amendment did not have an impact on the Group's financial statements since the Group is not setting off financial instruments and does not have offsetting arrangement.

- PFRS 10, *Consolidated Financial Statements*
The Group adopted PFRS 10 in the current year. PFRS 10 replaced the portion of PAS 27, *Consolidated and Separate Financial Statements*, that addressed the accounting for consolidated financial statements. It also included the issues raised in SIC 12, *Consolidation - Special Purpose Entities*. PFRS 10 established a single control model that applied to all entities including special purpose entities. The changes introduced by PFRS 10 require management to exercise significant judgment to determine which entities are controlled, and therefore, are required to be consolidated by a parent, compared with the requirements that were in PAS 27.

The application of PFRS 10 affected the accounting for the Group's interest in Toledo Mining Corporation (TMC). For the year ended December 31, 2012, TMC was considered to be an associate under the previously existing PAS 28, *Investments in Associates*, and was accounted for using the equity method. On December 20, 2013, the Group assessed that it controls TMC based on the factors explained in Note 3. The assets, liabilities and equity of TMC have been



consolidated under provisional accounting in the financial statements of the Group on the date control over TMC was obtained. The Group also reviewed its existing arrangement with entities which are more than 50% owned and has determined that it does not have control over these investees (see Notes 3 and 11).

- PFRS 11, *Joint Arrangements*
PFRS 11 replaced PAS 31, *Interests in Joint Ventures*, and SIC 13, *Jointly Controlled Entities - Non-Monetary Contributions by Venturers*. PFRS 11 removed the option to account for jointly controlled entities using proportionate consolidation. Instead, jointly controlled entities that meet the definition of a joint venture must be accounted for using the equity method.

The application of PFRS 11 impacted the Group's accounting of its interest in a joint venture, DMCI - First Balfour (DMFB) Joint Venture (see Note 11). The Group has a 51% interest in DMFB Joint Venture. Prior to the transition to PFRS 11, DMFB Joint Venture was classified as a jointly controlled entity and the Group's share of the assets, liabilities, revenue, income and expenses was proportionately consolidated in the consolidated financial statements. Upon adoption of PFRS 11, the Group has determined that its interest in DMFB Joint Venture should be classified as a joint venture under PFRS 11 and it is required to be accounted for using the equity method (see Note 11). The transition was applied retrospectively as required by PFRS 11 and the opening balances at January 1, 2012 and the comparative information for the years ended December 31, 2012 and 2011 have been restated. The effect of applying PFRS 11 on the Group's financial statements is as follows (amounts in thousands):

	December 31, 2012	January 1, 2012
Total Assets	₱55,010	₱75,971
Total Liabilities	(55,010)	(75,971)

There was no impact to the comprehensive income and total equity as of December 31, 2012 and 2011.

Impact on statements of cash flows is on operating activities, decreasing cash flows by ₱6.08 million and increasing cash flows by ₱27.70 million for the years ended December 31, 2012 and 2011, respectively.

The application of PFRS 11 also impacted the Group's accounting for its interest in ENK Plc. Prior to the transition to PFRS 11, ENK Plc. is classified as an associate of the Group and accounted for using the equity method of accounting. Upon adoption of PFRS 11, the Group has determined that its interest in ENK Plc. should be classified as a joint venture under the standard and continue to account for it using the equity method. The application affects the disclosures only and has no effect on the Group's financial statements (see Notes 3 and 11).

- PFRS 12, *Disclosure of Interests in Other Entities*
PFRS 12 sets out the requirements for disclosures relating to an entity's interests in subsidiaries, joint arrangements, associates and structured entities. The requirements in PFRS 12 are more comprehensive than the previously existing disclosure requirements for subsidiaries (for example, where a subsidiary is controlled with less than a majority of voting rights). While the Group has subsidiaries with material non-controlling interests, there are no unconsolidated structured entities. PFRS 12 disclosures are provided in Notes 11 and 32.



- PFRS 13, *Fair Value Measurement*

PFRS 13 establishes a single source of guidance under PFRSs for all fair value measurements. PFRS 13 does not change when an entity is required to use fair value, but rather provides guidance on how to measure fair value under PFRS. PFRS 13 defines fair value as an exit price. PFRS 13 also requires additional disclosures.

As a result of the guidance in PFRS 13, the Group re-assessed its policies for measuring fair values, in particular, its valuation inputs such as non-performance risk for fair value measurement of liabilities. The Group has assessed that the application of PFRS 13 has not materially impacted the fair value measurements of the Group. Additional disclosures, where required, are provided in the individual notes relating to the assets and liabilities whose fair values were determined. Fair value hierarchy is provided in Note 36.

- PAS 1, *Presentation of Financial Statements - Presentation of Items of Other Comprehensive Income or OCI (Amendments)*

The amendments to PAS 1 introduced a grouping of items presented in OCI. Items that will be reclassified (or “recycled”) to profit or loss at a future point in time (for example, upon derecognition or settlement) will be presented separately from items that will never be recycled. The statements of comprehensive income accordingly followed the new requirement of presentation. The amendments affect presentation only and have no impact on the Group’s financial position or performance.

- PAS 19, *Employee Benefits (Revised)*

On January 1, 2013, the Group adopted the Revised PAS 19 Employee Benefits.

For defined benefit plans, the Revised PAS 19 requires all actuarial gains and losses to be recognized in other comprehensive income and unvested past service costs previously recognized over the average vesting period to be recognized immediately in profit or loss when incurred.

Prior to adoption of the Revised PAS 19, the Group recognized actuarial gains and losses as income or expense when the net cumulative unrecognized gains and losses for each individual plan at the end of the previous period exceeded 10% of the higher of the defined benefit obligation and the fair value of the plan assets and recognized unvested past service costs as an expense on a straight-line basis over the average vesting period until the benefits become vested. Upon adoption of the Revised PAS 19, the Group changed its accounting policy to recognize all actuarial gains and losses in other comprehensive income and all past service costs in profit or loss in the period they occur.

The Revised PAS 19 replaced the interest cost and expected return on plan assets with the concept of net interest on defined benefit liability or asset which is calculated by multiplying the net balance sheet defined benefit liability or asset by the discount rate used to measure the employee benefit obligation, each as at the beginning of the annual period.

The Revised PAS 19 also amended the definition of short-term employee benefits and requires employee benefits to be classified as short-term based on expected timing of settlement rather than the employee’s entitlement to the benefits. In addition, the Revised PAS 19 modifies the timing of recognition for termination benefits. The modification requires the termination benefits to be recognized at the earlier of when the offer cannot be withdrawn or when the related restructuring costs are recognized.



Changes to definition of short-term employee benefits and timing of recognition for termination benefits do not have any impact to the Group's financial position and financial performance.

The Group reviewed its existing employee benefit and determined that the amended standard has significant impact on its accounting for retirement benefits. The Group obtained the services of an external actuary to compute the impact to the consolidated financial statements upon adoption of the standard. The effects are detailed below (amounts in thousands):

	December 31, 2013	December 31, 2012	January 1, 2012
Increase (decrease) in:			
<u>Consolidated Statement of Financial Position</u>			
Pension asset	₱795,155	₱697,788	₱518,021
Pension liability	(84,292)	(99,198)	(98,192)
Deferred tax assets	(870)	12,477	4,604
Deferred tax liabilities	38,466	44,329	22,155
Other comprehensive income	516,675	383,132	153,801
Retained earnings	329,732	395,065	450,846
Non-controlling interests	(6,296)	(13,063)	(5,985)
	2013	2012	2011
<u>Consolidated Statement of Income</u>			
Operating expenses	₱85,400	₱56,611	₱33,703
Profit before income tax	(85,400)	(56,611)	(33,703)
Income tax benefit	16,425	1,140	1,486
Profit for the year	(₱68,975)	(₱55,471)	(₱32,217)
Attributable to:			
Equity holders of the parent	(₱65,333)	(₱55,781)	(₱32,497)
Non-controlling interests	(3,642)	310	280
Earnings per share		(₱0.02)	(₱0.01)
	2013	2012	2011
<u>Consolidated Statement of Comprehensive Income</u>			
Remeasurement gains	₱164,272	₱237,384	₱166,533
Income tax effects	(20,320)	(15,441)	(13,637)
Other comprehensive income for the year, net of tax	143,952	221,943	152,896
Total comprehensive income for the year	₱74,977	₱166,472	₱120,679
Other comprehensive income, net of tax, attributable to:			
Equity holders of the parent	₱133,543	₱229,331	₱153,801
Non-controlling interests	10,409	(7,388)	(905)



The adoption did not have impact on consolidated statement of cash flows.

- PAS 27, *Separate Financial Statements* (as revised in 2011)
As a consequence of the issuance of the new PFRS 10 and PFRS 12 what remains of PAS 27 is limited to accounting for subsidiaries, jointly controlled entities, and associates in the separate financial statements. The adoption of the amended PAS 27 did not have a significant impact on the separate financial statements of the entities in the Group.
- PAS 28, *Investments in Associates and Joint Ventures* (as revised in 2011)
As a consequence of the issuance of the new PFRS 11 and PFRS 12, PAS 28 has been renamed PAS 28, *Investments in Associates and Joint Ventures*, and describes the application of the equity method to investments in joint ventures in addition to associates.
- Philippine Interpretation International Financial Reporting Interpretations Committee (IFRIC) 20, *Stripping Costs in the Production Phase of a Surface Mine*
This interpretation applies to waste removal (stripping) costs incurred in surface mining activity, during the production phase of the mine. The interpretation addresses the accounting for the benefit from the stripping activity. Management has assessed the impact of the interpretation on its coal mining activities both for the open pit mining and the one under exploration and evaluation. Management has concluded that its existing accounting policy is consistent with the requirements of the new interpretation and therefore the adoption did not impact both the financial position and performance of the Group.
- PFRS 1, *First-time Adoption of Philippine Financial Reporting Standards - Government Loans* (Amendments)
The amendments to PFRS 1 require first-time adopters to apply the requirements of PAS 20, *Accounting for Government Grants and Disclosure of Government Assistance*, prospectively to government loans existing at the date of transition to PFRS. However, entities may choose to apply the requirements of PAS 39, *Financial Instruments: Recognition and Measurement*, and PAS 20 to government loans retrospectively if the information needed to do so had been obtained at the time of initially accounting for those loans. These amendments are not relevant to the Group.

Annual Improvements to PFRSs (2009-2011 cycle)

The *Annual Improvements to PFRSs (2009-2011 cycle)* contain non-urgent but necessary amendments to PFRSs. The Group adopted these amendments for the current year.

- PFRS 1, *First-time Adoption of PFRS - Borrowing Costs*
The amendment clarifies that, upon adoption of PFRS, an entity that capitalized borrowing costs in accordance with its previous generally accepted accounting principles, may carry forward, without any adjustment, the amount previously capitalized in its opening statement of financial position at the date of transition. Subsequent to the adoption of PFRS, borrowing costs are recognized in accordance with PAS 23, *Borrowing Costs*. The amendment does not apply to the Group as it is not a first-time adopter of PFRS.



- *PAS 1, Presentation of Financial Statements - Clarification of the Requirements for Comparative Information*
These amendments clarify the requirements for comparative information that are disclosed voluntarily and those that are mandatory due to retrospective application of an accounting policy, or retrospective restatement or reclassification of items in the financial statements. An entity must include comparative information in the related notes to the financial statements when it voluntarily provides comparative information beyond the minimum required comparative period. The additional comparative period does not need to contain a complete set of financial statements. On the other hand, supporting notes for the third balance sheet (mandatory when there is a retrospective application of an accounting policy, or retrospective restatement or reclassification of items in the financial statements) are not required. As a result, the Group has not included comparative information in respect of the opening statement of financial position as at January 1, 2012. The Group presented comparative information in the notes for the impact of adoption of the Revised PAS 19 (see Note 23).
- *PAS 16, Property, Plant and Equipment - Classification of Servicing Equipment*
The amendment clarifies that spare parts, stand-by equipment and servicing equipment should be recognized as property, plant and equipment when they meet the definition of property, plant and equipment and should be recognized as inventory if otherwise. The amendment does not have any significant impact on the Group's financial position or performance. The Group does not expect the adoption of the standards and interpretations to have a significant impact on its financial statements unless otherwise indicated.
- *PAS 32, Financial Instruments: Presentation - Tax Effect of Distribution to Holders of Equity Instruments*
The amendment clarifies that income taxes relating to distributions to equity holders and to transaction costs of an equity transaction are accounted for in accordance with PAS 12, *Income Taxes*. The amendment does not have any significant impact on the Group's financial position or performance.
- *PAS 34, Interim Financial Reporting - Interim Financial Reporting and Segment Information for Total Assets and Liabilities*
The amendment clarifies that the total assets and liabilities for a particular reportable segment need to be disclosed only when the amounts are regularly provided to the chief operating decision maker and there has been a material change from the amount disclosed in the entity's previous annual financial statements for that reportable segment. The amendment affects disclosures only and has no impact on the Group's financial position or performance.

Standards and Interpretation Issued but not yet Effective

The Group has not adopted the following PFRS and Philippine Interpretations which are not yet effective as of December 31, 2013. The Group will adopt these standards when they become effective. The Group does not expect the adoption of these standards to have a significant impact in the consolidated financial statements, unless otherwise stated.

- *PAS 36, Impairment of Assets - Recoverable Amount Disclosures for Non-Financial Assets (Amendments)*
These amendments remove the unintended consequences of PFRS 13 on the disclosures required under PAS 36. In addition, these amendments require disclosure of the recoverable amounts for the assets or cash-generating units for which impairment loss has been recognized



or reversed during the period. These amendments are effective retrospectively for annual periods beginning on or after January 1, 2014 with earlier application permitted, provided PFRS 13 is also applied. The amendments affect disclosures only and have no impact on the Group's financial position or performance.

- **Investment Entities (Amendments to PFRS 10, PFRS 12 and PAS 27)**
These amendments are effective for annual periods beginning on or after January 1, 2014. They provide an exception to the consolidation requirement for entities that meet the definition of an investment entity under PFRS 10. The exception to consolidation requires investment entities to account for subsidiaries at fair value through profit or loss. It is not expected that this amendment would be relevant to the Group since none of the entities in the Group would qualify to be an investment entity under PFRS 10.
- **Philippine Interpretation IFRIC 21, *Levies***
IFRIC 21 clarifies that an entity recognizes a liability for a levy when the activity that triggers payment, as identified by the relevant legislation, occurs. For a levy that is triggered upon reaching a minimum threshold, the interpretation clarifies that no liability should be anticipated before the specified minimum threshold is reached. IFRIC 21 is effective for annual periods beginning on or after January 1, 2014. The Group does not expect that IFRIC 21 will have material financial impact in future financial statements.
- **PAS 39, *Financial Instruments: Recognition and Measurement - Novation of Derivatives and Continuation of Hedge Accounting* (Amendments)**
These amendments provide relief from discontinuing hedge accounting when novation of a derivative designated as a hedging instrument meets certain criteria. These amendments are effective for annual periods beginning on or after January 1, 2014. The Company has no derivatives designated as hedging instrument and derivatives novated as of the financial reporting period.
- **PAS 32, *Financial Instruments: Presentation - Offsetting Financial Assets and Financial Liabilities* (Amendments)**
The amendments clarify the meaning of "currently has a legally enforceable right to set-off" and also clarify the application of the PAS 32 offsetting criteria to settlement systems (such as central clearing house systems) which apply gross settlement mechanisms that are not simultaneous. The amendments affect presentation only and have no impact on the Group's financial position or performance. The amendments to PAS 32 are to be retrospectively applied for annual periods beginning on or after January 1, 2014.
- **PAS 19, *Employee Benefits - Defined Benefit Plans: Employee Contributions* (Amendments)**
The amendments apply to contributions from employees or third parties to defined benefit plans. Contributions that are set out in the formal terms of the plan shall be accounted for as reductions to current service costs if they are linked to service or as part of the remeasurements of the net defined benefit asset or liability if they are not linked to service. Contributions that are discretionary shall be accounted for as reductions of current service cost upon payment of these contributions to the plans. The amendments to PAS 19 are to be retrospectively applied for annual periods beginning on or after July 1, 2014. The amendment has no significant impact on the Company's financial position and performance since the employees are not required to make contribution to the Company's retirement fund.



Annual Improvements to PFRSs (2010-2012 cycle)

The *Annual Improvements to PFRSs (2010-2012 cycle)* contain non-urgent but necessary amendments to the following standards:

- *PFRS 2, Share-based Payment - Definition of Vesting Condition*
The amendment revised the definitions of vesting condition and market condition and added the definitions of performance condition and service condition to clarify various issues. This amendment shall be prospectively applied to share-based payment transactions for which the grant date is on or after July 1, 2014. This amendment does not apply to the Group as it has no share-based payments.
- *PFRS 3, Business Combinations - Accounting for Contingent Consideration in a Business Combination*
The amendment clarifies that a contingent consideration that meets the definition of a financial instrument should be classified as a financial liability or as equity in accordance with PAS 32. Contingent consideration that is not classified as equity is subsequently measured at fair value through profit or loss whether or not it falls within the scope of PAS 39. The amendment shall be prospectively applied to business combinations for which the acquisition date is on or after July 1, 2014. The Group shall consider this amendment for future business combinations.
- *PFRS 8, Operating Segments - Aggregation of Operating Segments and Reconciliation of the Total of the Reportable Segments' Assets to the Entity's Assets*
The amendments require entities to disclose the judgment made by management in aggregating two or more operating segments. This disclosure should include a brief description of the operating segments that have been aggregated in this way and the economic indicators that have been assessed in determining that the aggregated operating segments share similar economic characteristics. The amendments also clarify that an entity shall provide reconciliations of the total of the reportable segments' assets to the entity's assets if such amounts are regularly provided to the chief operating decision maker. These amendments are effective for annual periods beginning on or after July 1, 2014 and are applied retrospectively. The amendments have no impact on the Group's financial position or performance.
- *PFRS 13, Fair Value Measurement - Short-term Receivables and Payables*
The amendment clarifies that short-term receivables and payables with no stated interest rates can be held at invoice amounts when the effect of discounting is immaterial.
- *PAS 16, Property, Plant and Equipment - Revaluation Method - Proportionate Restatement of Accumulated Depreciation*
The amendment clarifies that, upon revaluation of an item of property, plant and equipment, the carrying amount of the asset shall be adjusted to the revalued amount, and the asset shall be treated in one of the following ways:
 - a) The gross carrying amount is adjusted in a manner that is consistent with the revaluation of the carrying amount of the asset. The accumulated depreciation at the date of revaluation is adjusted to equal the difference between the gross carrying amount and the carrying amount of the asset after taking into account any accumulated impairment losses.
 - b) The accumulated depreciation is eliminated against the gross carrying amount of the asset.



The amendment is effective for annual periods beginning on or after July 1, 2014. The amendment shall apply to all revaluations recognized in annual periods beginning on or after the date of initial application of this amendment and in the immediately preceding annual period. The amendment has no impact on the Group's financial position or performance.

- PAS 24, *Related Party Disclosures - Key Management Personnel*
The amendments clarify that an entity is a related party of the reporting entity if the said entity, or any member of a group for which it is a part of, provides key management personnel services to the reporting entity or to the parent company of the reporting entity. The amendments also clarify that a reporting entity that obtains management personnel services from another entity (also referred to as management entity) is not required to disclose the compensation paid or payable by the management entity to its employees or directors. The reporting entity is required to disclose the amounts incurred for the key management personnel services provided by a separate management entity. The amendments are effective for annual periods beginning on or after July 1, 2014 and are applied retrospectively. The amendments affect disclosures only and have no impact on the Group's financial position or performance.
- PAS 38, *Intangible Assets - Revaluation Method - Proportionate Restatement of Accumulated Amortization*
The amendments clarify that, upon revaluation of an intangible asset, the carrying amount of the asset shall be adjusted to the revalued amount, and the asset shall be treated in one of the following ways:
 - a) The gross carrying amount is adjusted in a manner that is consistent with the revaluation of the carrying amount of the asset. The accumulated amortization at the date of revaluation is adjusted to equal the difference between the gross carrying amount and the carrying amount of the asset after taking into account any accumulated impairment losses.
 - b) The accumulated amortization is eliminated against the gross carrying amount of the asset.

The amendments also clarify that the amount of the adjustment of the accumulated amortization should form part of the increase or decrease in the carrying amount accounted for in accordance with the standard.

The amendments are effective for annual periods beginning on or after July 1, 2014. The amendments shall apply to all revaluations recognized in annual periods beginning on or after the date of initial application of this amendment and in the immediately preceding annual period. The amendments have no impact on the Group's financial position or performance.

Annual Improvements to PFRSs (2011-2013 cycle)

The *Annual Improvements to PFRSs (2011-2013 cycle)* contain non-urgent but necessary amendments to the following standards:

- PFRS 1, *First-time Adoption of Philippine Financial Reporting Standards - Meaning of 'Effective PFRSs'*
The amendment clarifies that an entity may choose to apply either a current standard or a new standard that is not yet mandatory, but that permits early application, provided either standard is applied consistently throughout the periods presented in the entity's first PFRS financial statements. This amendment is not applicable to the Group as it is not a first-time adopter of PFRS.



- *PFRS 3, Business Combinations - Scope Exceptions for Joint Arrangements*
The amendment clarifies that PFRS 3 does not apply to the accounting for the formation of a joint arrangement in the financial statements of the joint arrangement itself. The amendment is effective for annual periods beginning on or after July 1, 2014 and is applied prospectively.
- *PFRS 13, Fair Value Measurement - Portfolio Exception*
The amendment clarifies that the portfolio exception in PFRS 13 can be applied to financial assets, financial liabilities and other contracts. The amendment is effective for annual periods beginning on or after July 1, 2014 and is applied prospectively. The amendment has no significant impact on the Group's financial position or performance.
- *PAS 40, Investment Property*
The amendment clarifies the interrelationship between PFRS 3 and PAS 40 when classifying property as investment property or owner-occupied property. The amendment stated that judgment is needed when determining whether the acquisition of investment property is the acquisition of an asset or a group of assets or a business combination within the scope of PFRS 3. This judgment is based on the guidance of PFRS 3. This amendment is effective for annual periods beginning on or after July 1, 2014 and is applied prospectively. The amendment has no significant impact on the Group's financial position or performance.
- *PFRS 9, Financial Instruments*
PFRS 9, as issued, reflects the first and third phases of the project to replace PAS 39 and applies to the classification and measurement of financial assets and liabilities and hedge accounting, respectively. Work on the second phase, which relate to impairment of financial instruments, and the limited amendments to the classification and measurement model is still ongoing, with a view to replace PAS 39 in its entirety. PFRS 9 requires all financial assets to be measured at fair value at initial recognition. A debt financial asset may, if the fair value option (FVO) is not invoked, be subsequently measured at amortized cost if it is held within a business model that has the objective to hold the assets to collect the contractual cash flows and its contractual terms give rise, on specified dates, to cash flows that are solely payments of principal and interest on the principal outstanding. All other debt instruments are subsequently measured at fair value through profit or loss. All equity financial assets are measured at fair value either through OCI or profit or loss. Equity financial assets held for trading must be measured at fair value through profit or loss. For liabilities designated as at FVPL using the fair value option, the amount of change in the fair value of a liability that is attributable to changes in credit risk must be presented in OCI. The remainder of the change in fair value is presented in profit or loss, unless presentation of the fair value change relating to the entity's own credit risk in OCI would create or enlarge an accounting mismatch in profit or loss. All other PAS 39 classification and measurement requirements for financial liabilities have been carried forward to PFRS 9, including the embedded derivative bifurcation rules and the criteria for using the FVO. The adoption of the first phase of PFRS 9 will have an effect on the classification and measurement of the Group's financial assets, but will potentially have no impact on the classification and measurement of financial liabilities.

On hedge accounting, PFRS 9 replaces the rules-based hedge accounting model of PAS 39 with a more principles-based approach. Changes include replacing the rules-based hedge effectiveness test with an objectives-based test that focuses on the economic relationship between the hedged item and the hedging instrument, and the effect of credit risk on that economic relationship; allowing risk components to be designated as the hedged item, not only



for financial items, but also for non-financial items, provided that the risk component is separately identifiable and reliably measurable; and allowing the time value of an option, the forward element of a forward contract and any foreign currency basis spread to be excluded from the designation of a financial instrument as the hedging instrument and accounted for as costs of hedging. PFRS 9 also requires more extensive disclosures for hedge accounting.

PFRS 9 currently has no mandatory effective date. PFRS 9 may be applied before the completion of the limited amendments to the classification and measurement model and impairment methodology. The Group will not adopt the standard before the completion of the limited amendments and the second phase of the project.

In compliance with SEC Memorandum Circular No. 3, Series of 2012, the Group has conducted a study on the impact of an early adoption of PFRS 9. After careful consideration of the results on the impact evaluation, the Group has decided not to early adopt PFRS 9 for its 2013 annual financial reporting. Therefore, these consolidated financial statements do not reflect the impact of the said standard.

- *Philippine Interpretation IFRIC 15, Agreements for the Construction of Real Estate*
This interpretation covers accounting for revenue and associated expenses by entities that undertake the construction of real estate directly or through subcontractors. The interpretation requires that revenue on construction of real estate be recognized only upon completion, except when such contract qualifies as construction contract to be accounted for under PAS 11, *Construction Contracts*, or involves rendering of services in which case revenue is recognized based on stage of completion. Contracts involving provision of services with the construction materials and where the risks and reward of ownership are transferred to the buyer on a continuous basis will also be accounted for based on stage of completion. The SEC and the Financial Reporting Standards Council have deferred the effectivity of this interpretation until the final Revenue standard is issued by the International Accounting Standards Board and an evaluation of the requirements of the final Revenue standard against the practices of the Philippine real estate industry is completed.

Significant Accounting Policies

Cash and Cash Equivalents

Cash includes cash on hand and in banks. Cash equivalents are short-term, highly liquid investments that are readily convertible to known amounts of cash with original maturities of three months or less from the date of placement and that are subject to an insignificant risk of changes in value.

Financial Instruments

Date of Recognition

The Group recognizes a financial asset or a financial liability in the consolidated statement of financial position when it becomes a party to the contractual provisions of the instrument. Purchases or sales of financial assets that require delivery of assets within the time frame established by regulation or convention in the marketplace are recognized on the settlement date.

Initial Recognition of Financial Instruments

All financial assets and financial liabilities are initially recognized at fair value. Except for financial assets at FVPL, the initial measurement of financial assets includes transaction costs. The Group classifies its financial assets in the following categories: financial assets at FVPL, held-to-maturity (HTM) investments, AFS financial assets, and loans and receivables. The Group



classifies its financial liabilities as financial liabilities at FVPL and other financial liabilities. The classification depends on the purpose for which the investments were acquired and whether these are quoted in an active market. Management determines the classification of its investments at initial recognition and, where allowed and appropriate, re-evaluates such designation at every reporting date.

Financial instruments are classified as liabilities or equity in accordance with the substance of the contractual arrangement. Interest, dividends, gains and losses relating to a financial instrument or a component that is a financial liability, are reported as expense or income. Distributions to holders of financial instruments classified as equity are charged directly to equity net of any related income tax benefits.

The Group's financial instruments are classified as AFS financial assets, financial assets at FVPL, loans and receivables and other financial liabilities.

Fair Value Measurement

The Group measures financial instruments at fair value at each reporting date. Also, fair values of financial instruments measured at amortized cost and non-financial assets measured at cost such as investment properties are disclosed in Notes 12 and 36.

Fair value is the price that would be received to sell an asset or paid to transfer a liability in an orderly transaction between market participants at the measurement date. The fair value measurement is based on the presumption that the transaction to sell the asset or transfer the liability takes place either:

- In the principal market for the asset or liability, or
- In the absence of a principal market, in the most advantageous market for the asset or liability.

The principal or the most advantageous market must be accessible to by the Group.

The fair value of an asset or a liability is measured using the assumptions that market participants would use when pricing the asset or liability, assuming that market participants act in their economic best interest.

A fair value measurement of a non-financial asset takes into account a market participant's ability to generate economic benefits by using the asset in its highest and best use or by selling it to another market participant that would use the asset in its highest and best use.

The Group uses valuation techniques that are appropriate in the circumstances and for which sufficient data are available to measure fair value, maximizing the use of relevant observable inputs and minimizing the use of unobservable inputs.

All assets and liabilities for which fair value is measured or disclosed in the financial statements are categorized within the fair value hierarchy based on the lowest level input that is significant to the fair value measurement as a whole:

- Level 1 - Quoted (unadjusted) market prices in active markets for identical assets or liabilities
- Level 2 - Valuation techniques for which the lowest level input that is significant to the fair value measurement is directly or indirectly observable
- Level 3 - Valuation techniques for which the lowest level input that is significant to the fair value measurement is unobservable



For assets and liabilities that are recognized in the financial statements on a recurring basis, the Group determines whether transfers have occurred between Levels in the hierarchy by re-assessing categorization (based on the lowest level input that is significant to the fair value measurement as a whole) at the end of each reporting period.

For the purpose of fair value disclosures, the Group has determined classes of assets and liabilities on the basis of the nature, characteristics and risks of the asset or liability and the level of the fair value hierarchy as explained above.

Day 1 Difference

Where the transaction price in a non-active market is different to the fair value from other observable current market transactions in the same instrument or based on a valuation technique whose variables include only data from observable market, the Group recognizes the difference between the transaction price and fair value (a “Day 1” difference) in the consolidated statement of income under “Finance income” and “Finance costs” unless it qualifies for recognition as some other type of asset or liability. In cases where the valuation technique used is made of data which is not observable, the difference between the transaction price and model value is only recognized in the consolidated statement of income when the inputs become observable or when the instrument is derecognized. For each transaction, the Group determines the appropriate method of recognizing the ‘Day 1’ difference amount.

Financial Assets and Financial Liabilities at FVPL

Financial assets and financial liabilities at FVPL include financial assets and financial liabilities held for trading and financial assets and financial liabilities designated upon initial recognition as at FVPL.

Financial assets are classified as held for trading if they are acquired for the purpose of selling or repurchasing in the near term. Financial assets or financial liabilities held for trading are recorded in the consolidated statement of financial position at fair value. Changes in fair value relating to the held for trading positions are recognized in “Other income - net” account in the consolidated statement of income. Interest earned or incurred is recorded in interest income or expense, respectively, while dividend income is recorded when the right to receive payment has been established.

Financial assets may be designated at initial recognition as at FVPL if any of the following criteria are met:

- The designation eliminates or significantly reduces the inconsistent treatment that would otherwise arise from measuring the assets or liabilities or recognizing gains or losses on them on a different basis; or
- The assets are part of a group of financial assets which are managed and their performance evaluated on a fair value basis, in accordance with a documented risk management or investment strategy; or
- The financial instrument contains an embedded derivative that would need to be separately recorded.

The Group’s financial asset at FVPL pertains to investment in quoted equity securities (see Note 5). The Group does not have any financial liability at FVPL.



Loans and Receivables

Loans and receivables are nonderivative financial assets with fixed or determinable payments and fixed maturities that are not quoted in an active market. These are not entered into with the intention of immediate or short-term resale and are not designated as financial assets at FVPL or AFS financial assets. These are included in current assets if maturity is within 12 months from the reporting date; otherwise, these are classified as noncurrent assets. This accounting policy relates to the consolidated statement of financial position captions “Cash and cash equivalents”, “Receivables”, “Noncurrent receivables” and refundable and security deposits included under “Other noncurrent assets”.

After initial measurement, loans and receivables are subsequently measured at amortized cost using the effective interest method, less allowance for impairment. Amortized cost is calculated by taking into account any discount or premium on acquisition and fees that are an integral part of the effective interest rate (EIR) and transaction costs. The amortization is included in “Finance income” in the consolidated statement of income. The losses arising from impairment of such loans and receivables are recognized under “Other expenses” in the consolidated statement of income.

AFS Financial Assets

AFS financial assets are those which are designated as such or do not qualify to be classified or designated as at FVPL, HTM or loans and receivables. After initial measurement, AFS financial assets are measured at fair value with unrealized gains or losses being recognized in the consolidated statement of comprehensive income and are reported as “Net accumulated unrealized gains (losses) on AFS financial assets” in equity. When the investment is disposed of, the cumulative gain or loss previously recorded in equity is recognized in the consolidated statement of income. Interest earned or paid on the investments is reported as interest income or expense using the EIR. Dividends earned on investments are recognized in the consolidated statement of income when the right to receive payment has been established. The losses arising from impairment of such investments are recognized under “Other expenses” in the consolidated statement of income.

AFS financial assets are classified as current asset if verified to be realized within 12 months from reporting date.

When the fair value of AFS financial assets cannot be measured reliably because of lack of reliable estimates of future cash flows and discount rates necessary to calculate the fair values of unquoted equity instruments, then instruments are carried at cost less any allowance for impairment losses.

The Group’s AFS financial assets pertain to quoted and unquoted equity securities (Note 6).

Other Financial Liabilities

Issued financial instruments or their components, which are not designated as at FVPL are classified as other financial liabilities where the substance of the contractual arrangement results in the Group having an obligation either to deliver cash or another financial asset to the holder, or to satisfy the obligation other than by the exchange of a fixed amount of cash or another financial asset for a fixed number of own equity shares. The components of issued financial instruments that contain both liability and equity elements are accounted for separately, with the equity component being assigned the residual amount after deducting from the instrument as a whole the amount separately determined as the fair value of the liability component on the date of issue.



After initial measurement, other financial liabilities are subsequently measured at amortized cost using the effective interest method. Amortized cost is calculated by taking into account any discount or premium on the issue and fees that are integral parts of the EIR. Any effects of restatement of foreign currency-denominated liabilities are recognized in the consolidated statement of income.

Other financial liabilities relate to the consolidated statement of financial position captions, “Accounts and other payables”, “Liabilities for purchased land”, “Payable to related parties”, “Short-term and Long-term debt” and “Other noncurrent liabilities”.

Gains and losses are recognized under the “Other income” and “Other expense” accounts in the consolidated statement of income when the liabilities are derecognized or impaired, as well as through the amortization process.

Deferred Financing Costs

Deferred financing costs represent debt issue costs arising from the fees incurred to obtain project financing. This is included in the initial measurement of the related debt. The deferred financing costs are treated as a discount on the related debt and are amortized using the effective interest method over the term of the related debt.

Customers’ Advances and Deposits

Customers’ advances and deposits represent payment from buyers which have not yet reached the minimum required percentage for recording real estate transactions. When the level of required payment is reached and the revenue recognition criteria is met, sales are recognized and these deposits and downpayments will be applied against the related receivables.

Impairment of Financial Assets

The Group assesses at each reporting date whether there is objective evidence that a financial asset or group of financial assets is impaired. A financial asset or a group of financial assets is deemed to be impaired if, and only if, there is objective evidence of impairment as a result of one or more events that has occurred after the initial recognition of the asset (an incurred ‘loss event’) and that loss event (or events) has an impact on the estimated future cash flows of the financial asset or the group of financial assets that can be reliably estimated. Evidence of impairment may include indications that the borrower or a group of borrowers is experiencing significant financial difficulty, default or delinquency in interest or principal payments, the probability that they will enter bankruptcy or other financial reorganization and where observable data indicate that there is measurable decrease in the estimated future cash flows, such as changes in arrears or economic conditions that correlate with defaults.

Loans and Receivables

For loans and receivables carried at amortized cost, the Group first assesses whether objective evidence of impairment exists individually for financial assets that are individually significant, or collectively for financial assets that are not individually significant. If the Group determines that no objective evidence of impairment exists for individually assessed financial asset, whether significant or not, it includes the asset in a group of financial assets with similar credit risk characteristics and collectively assesses for impairment. Those characteristics are relevant to the estimation of future cash flows for groups of such assets by being indicative of the debtors’ ability to pay all amounts due according to the contractual terms of the assets being evaluated. Assets that are individually assessed for impairment and for which an impairment loss is, or continues to be, recognized are not included in a collective assessment for impairment.



If there is objective evidence that an impairment loss has been incurred, the amount of the loss is measured as the difference between the asset's carrying amount and the present value of the estimated future cash flows (excluding future credit losses that have not been incurred) discounted at the financial assets' original EIR (i.e., the EIR computed at initial recognition). The carrying amount of the asset is reduced through the use of an allowance account and the amount of loss is charged to the consolidated statement of income during the period in which it arises. Interest income continues to be recognized based on the original EIR of the asset. Receivables, together with the associated allowance accounts, are written off when there is no realistic prospect of future recovery and all collateral has been realized.

If, in a subsequent year, the amount of the estimated impairment loss decreases because of an event occurring after the impairment was recognized, the previously recognized impairment loss is reversed. Any subsequent reversal of an impairment loss is recognized in the consolidated statement of income, to the extent that the carrying value of the asset does not exceed its amortized cost at the reversal date.

For the purpose of a collective evaluation of impairment, financial assets are grouped on the basis of such credit risk characteristics as industry, customer type, customer location, past-due status and term. Future cash flows in a group of financial assets that are collectively evaluated for impairment are estimated on the basis of historical loss experience for assets with credit risk characteristics similar to those in the group. Historical loss experience is adjusted on the basis of current observable data to reflect the effects of current conditions that did not affect the period on which the historical loss experience is based and to remove the effects of conditions in the historical period that do not exist currently. The methodology and assumptions used for estimating future cash flows are reviewed annually by the Group to reduce any differences between loss estimates and actual loss experience.

Financial Assets Carried at Cost

If there is an objective evidence that an impairment loss has been incurred on an unquoted equity instrument that is not carried at fair value because its fair value cannot be reliably measured, the amount of the loss is measured as the difference between the carrying amount and the present value of estimated future cash flows discounted at the current market rate of return for a similar financial asset.

AFS Financial Assets

For AFS financial assets, the Group assesses at each reporting date whether there is objective evidence that a financial asset or group of financial assets is impaired.

In case of equity investments classified as AFS financial assets, impairment would include a significant or prolonged decline in the fair value of the investments below its cost. Where there is evidence of impairment, the cumulative loss - measured as the difference between the acquisition cost and the current fair value, less any impairment loss on that financial asset previously recognized in the consolidated statement of income - is removed from equity and recognized in the consolidated statement of income under "Other expenses" account. Impairment losses on equity investments are not reversed through the consolidated statement of income. Increases in fair value after impairment are recognized directly in the consolidated statement of comprehensive income.

Offsetting Financial Instruments

Financial assets and financial liabilities are only offset and the net amount reported in the consolidated statement of financial position when there is a legally enforceable right to set off the recognized amounts and the Group intends to either settle on a net basis, or to realize the asset and settle the liability simultaneously.



Derecognition of Financial Assets and Liabilities

Financial Asset

A financial asset (or, where applicable a part of a financial asset or part of a group of similar financial assets) is derecognized when:

- the rights to receive cash flows from the asset have expired;
- the Group has transferred its rights to receive cash flows from the asset and either has assumed an obligation to pay them in full without material delay to a third party under a 'pass through' arrangement; or: (a) has transferred substantially all the risks and rewards of the asset, or (b) has neither transferred nor retained substantially all the risks and rewards of the asset, but has transferred control of the asset.

Where the Group has transferred its rights to receive cash flows from an asset and has neither transferred nor retained substantially all the risk and rewards of the asset nor transferred control of the asset, the asset is recognized to the extent of the Group's continuing involvement in the asset. Continuing involvement that takes the form of a guarantee over the transferred asset is measured at the lower of the carrying amount of the asset and the maximum amount of consideration that the Group could be required to repay.

Financial Liability

A financial liability is derecognized when the obligation under the liability is discharged or canceled or has expired.

Where an existing financial liability is replaced by another from the same lender on substantially different terms, or the terms of an existing liability are substantially modified, such an exchange or modification is treated as a derecognition of the original liability and the recognition of a new liability, and the difference in the respective carrying amounts is recognized in the consolidated statement of income.

Embedded Derivative

The Group assesses the existence of an embedded derivative on the date it first becomes a party to the contract, and performs re-assessment where there is a change to the contract that significantly modifies the cash flows.

Embedded derivatives are bifurcated from their host contracts and carried at fair value with fair value changes being reported through consolidated statement of income, when the entire hybrid contracts (composed of both the host contract and the embedded derivative) are not accounted for as financial instruments designated at FVPL; when their economic risks and characteristics are not clearly and closely related to those of their respective host contracts; and when a separate instrument with the same terms as the embedded derivative would meet the definition of a derivative.

As of December 31, 2013 and 2012, the Group's identified embedded derivatives consists of prepayment options that are not required to be bifurcated from the host instruments as these were assessed to be clearly and closely related to the host contracts.



Inventories

Real Estate Held for Sale and Development

Property acquired or being constructed for sale in the ordinary course of business, rather than to be held for rental or capital appreciation, is held as inventory and is measured at the lower of cost and net realizable value (NRV).

Cost includes:

- Land cost
- Amounts paid to contractors for construction
- Borrowing costs, planning and design costs, costs of site preparation, professional fees, property transfer taxes, construction overheads and other related costs

NRV is the estimated selling price in the ordinary course of the business, based on market prices at the reporting date, less estimated costs of completion and the estimated costs of sale.

Real estate inventories consist of housing units for sale and development and condominium units for sale.

Housing units for sale and development are carried at the lower of cost or NRV. Cost includes the acquisition costs of the land plus the costs incurred for the construction, development and improvement of the real estate projects. NRV is the estimated selling price in the ordinary course of business less estimated costs of completion and the estimated costs necessary to make the sale.

Condominium units for sale are also carried at the lower of cost or NRV. Costs include costs incurred for development, improvement and construction of condominium units.

Valuation allowance is provided for housing units for sale and development, condominium units for sale and development and undeveloped land when the NRV of the properties are less than their carrying amounts.

Coal Inventory

The cost of coal inventory is determined using the weighted average production cost method. The cost of extracted coal includes all stripping costs and other mine related costs incurred during the period and allocated on per metric ton basis by dividing the total production cost with the total volume of coal produced. Except for shiploading cost, which is a component of total minesite cost, all other costs are charged to production cost.

Materials-in-Transit

Cost is determined using the specific identification basis.

Equipment Parts and Supplies

The cost of equipment parts, materials and supplies is determined principally by the average cost method (either by moving average or weighted average production cost).

Equipment parts and supplies are transferred from inventories to property, plant and equipment when the use of such supplies is expected to extend the useful life of the asset and increase its economic benefit. Transfers between inventories to property, plant and equipment do not change the carrying amount of the inventories transferred and they do not change the cost of that inventory for measurement or disclosure purposes.



Equipment parts and supplies used for repairs and maintenance of the equipment are recognized in the consolidated statements of income when consumed.

Nickel Ore and Chromites Inventory

The cost of extracted nickel ore and chromites includes all direct materials, labor, fuel, outside services and other mine-related costs incurred during the period and allocated on per metric ton basis by dividing the total production cost with total volume of nickel ore produced. Except for shiploading cost, which is a component of total cost of sales, all other production related costs are charged to production cost.

Investments in Associates, Joint Controlled Entity and Others

An associate is an entity in which the Group has significant influence and which is neither a subsidiary nor a joint venture. Significant influence is the power to participate in the financial and operating policy decisions of the investee, but is not control or joint control over those policies.

A joint venture is a type of joint arrangement whereby the parties that have joint control of the arrangement have rights to the net assets of the joint venture. Joint control is the contractually agreed sharing of control of an arrangement, which exists only when decisions about the relevant activities require unanimous consent of the parties sharing control.

The considerations made in determining significant influence or joint control are similar to those necessary to determine control over subsidiaries. The Group's investments in its associate and joint venture are accounted for using the equity method.

Under the equity method, the investments in an associate or a joint venture is initially recognized at cost. The carrying amount of the investment is adjusted to recognize changes in the Group's share of net assets of the associate or joint venture since the acquisition date. Goodwill relating to the associate or joint venture is included in the carrying amount of the investment and is neither amortized nor individually tested for impairment.

The consolidated statement of income reflects the Group's share of the results of operations of the associate or joint venture. Any change in OCI of those investees is presented as part of the Group's OCI. In addition, when there has been a change recognized directly in the equity of the associate or joint venture, the Group recognizes its share of any changes, when applicable, in the statement of changes in equity. Unrealized gains and losses resulting from transactions between the Group and the associate or joint venture are eliminated to the extent of the interest in the associate or joint venture.

The aggregate of the Group's share of profit or loss of an associate and a joint venture is shown on the face of the consolidated statement of income outside operating profit and represents profit or loss after tax and non-controlling interests in the subsidiaries of the associate or joint venture.

The financial statements of the associate or joint venture are prepared for the same reporting period as the Group. When necessary, adjustments are made to bring the accounting policies in line with those of the Group.

After application of the equity method, the Group determines whether it is necessary to recognize an impairment loss on its investment in its associate or joint venture. At each reporting date, the Group determines whether there is objective evidence that the investment in the associate or joint venture is impaired. If there is such evidence, the Group calculates the amount of impairment as



the difference between the recoverable amount of the associate or joint venture and its carrying value, then recognizes the loss as 'Share of profit of an associate and a joint venture' in the consolidated statement of income.

Upon loss of significant influence over the associate or joint control over the joint venture, the Group measures and recognizes any retained investment at its fair value. Any difference between the carrying amount of the associate or joint venture upon loss of significant influence or joint control and the fair value of the retained investment and proceeds from disposal is recognized in consolidated statement of income.

Investment Properties

Investment properties comprise completed property and property under construction or redevelopment that are held to earn rentals or capital appreciation or both and that are not occupied by the companies in the Group. Investment properties are measured initially at cost, including transaction costs. Subsequent to initial recognition, investment properties, except land, are stated at cost less accumulated depreciation and amortization and any impairment in value. Land is stated at cost less any impairment in value. The carrying amount includes the cost of replacing part of an existing investment property at the time that cost is incurred if the recognition criteria are met and excludes the costs of day-to-day servicing of an investment property.

Investment properties are derecognized when either they have been disposed of or when the investment property is permanently withdrawn from use and no future economic benefit is expected from its disposal. The difference between the net disposal proceeds and the carrying amount of the asset is recognized in the consolidated statement of income in the period of derecognition.

Depreciation and amortization is calculated on a straight-line basis using the following estimated useful lives (EUL) from the time of acquisition of the investment properties:

	Years
Buildings and building improvements	5-25
Condominium units	25

The assets' residual value, useful life and depreciation and amortization methods are reviewed periodically to ensure that the period and method of depreciation and amortizations are consistent with the expected pattern of economic benefits from items of investment properties.

A transfer is made to investment property when there is a change in use, evidenced by ending of owner-occupation, commencement of an operating lease to another party or ending of construction or development. A transfer is made from investment property when and only when there is a change in use, evidenced by commencement of owner-occupation or commencement of development with a view to sale. A transfer between investment property, owner-occupied property and inventory does not change the carrying amount of the property transferred nor does it change the cost of that property for measurement or disclosure purposes.

Exploration and Evaluation Asset

Exploration and evaluation activity involves the search for mineral resources, the determination of technical feasibility and the assessment of commercial viability of an identified resource.



Exploration and evaluation activity includes:

- Researching and analyzing historical exploration data
- Gathering exploration data through geophysical studies
- Exploratory drilling and sampling
- Determining and examining the volume and grade of the resource
- Surveying transportation and infrastructure requirements
- Conducting market and finance studies

License costs paid in connection with a right to explore in an existing exploration area are capitalized and amortized over the term of the permit.

Once the legal right to explore has been acquired, exploration and evaluation expenditure is charged to consolidated statement of comprehensive income as incurred, unless the Group's management concludes that a future economic benefit is more likely than not to be realized. These costs include materials and fuel used, surveying costs, drilling costs and payments made to contractors.

In evaluating whether the expenditures meet the criteria to be capitalized, several different sources of information are used. The information that is used to determine the probability of future benefits depends on the extent of exploration and evaluation that has been performed.

Expenditure is transferred from 'Exploration and evaluation asset' to 'Mine properties' which is a subcategory of 'Property, plant and equipment' once the work completed to date supports the future development of the property and such development receives appropriate approvals.

After transfer of the exploration and evaluation asset, all subsequent expenditure on the construction, installation or completion of infrastructure facilities is capitalized in 'Mine properties'. Development expenditure is net of proceeds from the sale of ore extracted during the development phase.

Stripping Costs

As part of its mining operations, the Group incurs stripping (waste removal) costs both during the development phase and production phase of its operations. Stripping costs incurred in the development phase of a mine, before the production phase commences (development stripping), are capitalized as part of the cost of mine properties and subsequently amortized over its useful life using units of production method. The capitalization of development stripping costs ceases when the mine/component is commissioned and ready for use as intended by management.

Stripping activities undertaken during the production phase of a surface mine (production stripping) are accounted for as set out below. After the commencement of production further development of the mine may require a phase of unusually high stripping that is similar in nature to development phase stripping. The costs of such stripping are accounted for in the same way as development stripping (as outlined above).

Stripping costs incurred during the production phase are generally considered to create two benefits, being either the production of inventory or improved access to the coal body to be mined in the future. Where the benefits are realized in the form of inventory produced in the period, the production stripping costs are accounted for as part of the cost of producing those inventories.



Where the benefits are realized in the form of improved access to ore to be mined in the future, the costs are recognized as a noncurrent asset, referred to as a stripping activity asset, if the following criteria are met:

- Future economic benefits (being improved access to the coal body) are probable;
- The component of the coal body for which access will be improved can be accurately identified; and
- The costs associated with the improved access can be reliably measured.

If all of the criteria are not met, the production stripping costs are charged to the consolidated statement of comprehensive income as operating costs as they are incurred.

In identifying components of the coal body, the Group works closely with the mining operations department for each mining operation to analyze each of the mine plans. Generally, a component will be a subset of the total coal body, and a mine may have several components. The mine plans, and therefore the identification of components, can vary between mines for a number of reasons. These include, but are not limited to: the type of commodity, the geological characteristics of the coal body, the geographical location, and/or financial considerations.

The stripping activity asset is initially measured at cost, which is the accumulation of costs directly incurred to perform the stripping activity that improves access to the identified component of coal body, plus an allocation of directly attributable overhead costs. If incidental operations are occurring at the same time as the production stripping activity, but are not necessary for the production stripping activity to continue as planned, these costs are not included in the cost of the stripping activity asset. If the costs of the inventory produced and the stripping activity asset are not separately identifiable, a relevant production measure is used to allocate the production stripping costs between the inventory produced and the stripping activity asset. This production measure is calculated for the identified component of the coal body and is used as a benchmark to identify the extent to which the additional activity of creating a future benefit has taken place.

The stripping activity asset is accounted for as an addition to, or an enhancement of, an existing asset, being the mine asset, and is included as part of 'Mine properties' under 'Property, plant and equipment' in the consolidated statement of financial position. This forms part of the total investment in the relevant cash generating unit, which is reviewed for impairment if events or changes of circumstances indicate that the carrying value may not be recoverable.

The stripping activity asset is subsequently depreciated using the units of production method over the life of the identified component of the coal body that became more accessible as a result of the stripping activity. Economically recoverable reserves, which comprise proven and probable reserves, are used to determine the expected useful life of the identified component of the coal body. The stripping activity asset is then carried at cost less depreciation and any impairment losses.

Mining Reserves

Mining reserves are estimates of the amount of coal that can be economically and legally extracted from SMC's mining properties. SMC estimates its mining reserves based on information compiled by appropriately qualified persons relating to the geological data on the size, depth and shape of the coal body, and requires complex geological judgments to interpret the data. The estimation of recoverable reserves is based upon factors such as estimates of foreign exchange rates, commodity prices, future capital requirements, and production costs along with geological



assumptions and judgments made in estimating the size and grade of the coal body. Changes in the reserve estimates may impact upon the carrying value of property, plant and equipment, provision for decommissioning and site rehabilitation, recognition of deferred tax assets, and depreciation charges.

Property, Plant and Equipment

Property, plant and equipment, except land, are stated at cost less accumulated depreciation, depletion and amortization, and any impairment in value. Land is stated at cost, less any impairment in value.

The initial cost of property, plant and equipment comprises its purchase price, including import duties, taxes and any directly attributable costs of bringing the asset to its working condition and location for its intended use. Costs also include decommissioning and site rehabilitation cost. Expenditures incurred after the property, plant and equipment have been put into operation, such as repairs and maintenance and overhaul costs, are normally charged to operations in the period in which the costs are incurred. In situations where it can be clearly demonstrated that the expenditures have resulted in an increase in the future economic benefits expected to be obtained from the use of an item of property, plant and equipment beyond its originally assessed standard of performance, the expenditures are capitalized as additional cost of property, plant and equipment.

Construction in progress included in property, plant and equipment is stated at cost. This includes the cost of the construction of property, plant and equipment and other direct costs. Construction in-progress is not depreciated until such time that the relevant assets are completed and put into operational use.

Major repairs are capitalized as part of property, plant and equipment only when it is probable that future economic benefits associated with the item will flow to the Group and the cost of the items can be measured reliably. All other repairs and maintenance are charged against current operations as incurred.

Depreciation, depletion and amortization of assets commences once the assets are put into operational use.

Depreciation, depletion and amortization of property, plant and equipment are calculated on a straight-line basis over the following EUL of the respective assets or the remaining contract period, whichever is shorter:

	Years
Land improvements	5-17
Power plant, buildings and building improvements	5-25
Construction equipment, machinery and tools	5-10
Office furniture, fixtures and equipment	3-5
Transportation equipment	4-5
Conventional and continuous mining properties and equipment	2-13
Leasehold improvements	5-7

The EUL and depreciation, depletion and amortization methods are reviewed periodically to ensure that the period and methods of depreciation, depletion and amortization are consistent with the expected pattern of economic benefits from items of property, plant and equipment.



An item of property, plant and equipment is derecognized upon disposal or when no future economic benefits are expected to arise from the continued use of the asset. Any gain or loss arising on derecognition of the asset (calculated as the difference between the net disposal proceeds and the carrying amount of the item) is included in the consolidated statement of income in the year the item is derecognized.

Intangible Assets

Intangible assets, software costs, acquired separately are capitalized at cost and these are shown as part of the "Other noncurrent assets" account in the consolidated statement of financial position. Following initial recognition, intangible assets are measured at cost less accumulated amortization and provisions for impairment losses, if any. The useful lives of intangible assets with finite life are assessed at the individual asset level. Intangible assets with finite life are amortized over their EUL. The periods and method of amortization for intangible assets with finite useful lives are reviewed annually or earlier where an indicator of impairment exists.

Costs incurred to acquire and bring the computer software (not an integral part of its related hardware) to its intended use are capitalized as part of intangible assets. These costs are amortized over their EUL ranging from 3 to 5 years. Costs directly associated with the development of identifiable computer software that generate expected future benefits to the Group are recognized as intangible assets. All other costs of developing and maintaining computer software programs are recognized as expense when incurred.

Gains or losses arising from the derecognition of an intangible asset are measured as the difference between the net disposal proceeds and the carrying amount of the asset and are recognized in the consolidated statement of income when the asset is derecognized.

Impairment of Nonfinancial Assets

This accounting policy applies primarily to the Group's property, plant and equipment, investment properties, investments in associates and jointly controlled entities and intangible assets.

Property, Plant and Equipment, Investment Properties and Intangible Assets

The Group assesses at each reporting date whether there is an indication that an asset may be impaired. If any such indication exists, or when an annual impairment testing for an asset is required, the group makes an estimate of the asset's recoverable amount. An asset's recoverable amount is the higher of an asset's or cash generating unit's fair value less cost to sell and its value in use and is determined for an individual asset, unless the asset does not generate cash inflows that largely independent of those from other assets or group of assets. Where the carrying amount of an asset exceeds its recoverable amount, the asset is considered impaired and is written down to its recoverable amount. In assessing value in use, the estimated future cash flows are discounted to their present value using a pre-tax discount rate that reflects current market assessments of the time value of money and the risks specific to the asset.

A previously recognized impairment loss is reversed only if there has been a change in the estimates used to determine the asset's recoverable amount since the last impairment loss was recognized. If that is the case, the carrying amount of the asset is increased to its recoverable amount. That increased amount cannot exceed the carrying amount that would have been determined, net of depreciation, depletion and amortization, had no impairment loss been recognized for the asset in prior years. Such reversal is recognized in the consolidated statement of income unless the asset is carried at revalued amount, in which case the reversal is treated as a revaluation increase.



For investments in associates and jointly controlled entities, after application of the equity method, the Group determines whether it is necessary to recognize any additional impairment loss with respect to the Group's net investment in the investee companies. The Group determines at each reporting date whether there is any objective evidence that the investment in associates or jointly controlled entities is impaired. If this is the case, the Group calculates the amount of impairment as being the difference between the fair value and the carrying value of the investee company and recognizes the difference in the consolidated statement of income.

Equity

Capital stock is measured at par value for all shares issued. When the Group issues more than one class of stock, a separate account is maintained for each class of stock and the number of shares issued.

When the shares are sold at a premium, the difference between the proceeds and the par value is credited to "Additional paid-in capital" account. When shares are issued for a consideration other than cash, the proceeds are measured by the fair value of the consideration received.

Direct cost incurred related to the equity issuance, such as underwriting, accounting and legal fees, printing costs and taxes are charged to "Additional paid-in capital" account.

Retained earnings represent accumulated earnings of the Group, and any other adjustments to it as required by other standards, less dividends declared. The individual accumulated earnings of the subsidiaries and associates are available for dividend declaration when these are declared as dividends by the subsidiaries as approved by their respective Board of Directors.

Retained earnings are further restricted for the payment of dividends to the extent of the cost of common shares held in treasury.

Dividends on common shares are deducted from retained earnings when declared and approved by the BOD or shareholders of the Parent Company. Dividends payable are recorded as liability until paid. Dividends for the year that are declared and approved after the reporting date, if any, are dealt with as an event after the reporting date and disclosed accordingly.

Redeemed shares represent own equity instruments which are reacquired and are subsequently retired by the Group. No gain or loss is recognized in the consolidated statement of income upon retirement of the own equity instruments. When the assets are retired, the capital stock account is reduced by its par value and the excess of cost over par value is debited to additional paid-in capital recognized when the shares were issued and to retained earnings for the remaining balance.

The Parent Company's retained earnings available for dividend declaration as of December 31, 2013 and 2012 amounted to ₱18,603.69 million and ₱8,481.08 million, respectively.

Business Combinations and Goodwill

PFRS 3 provides that if the initial accounting for a business combination can be determined only provisionally by the end of the period in which the combination is effected because either the fair values to be assigned to the acquiree's identifiable assets, liabilities or contingent liabilities or the cost of the combination can be determined only provisionally, the acquirer shall account for the combination using those provisional values. The acquirer shall recognize any adjustments to those provisional values as a result of completing the initial accounting within twelve months of the acquisition date as follows: (i) the carrying amount of the identifiable asset, liability or contingent liability that is recognized or adjusted as a result of completing the initial accounting shall be calculated as if its fair value at the acquisition date had been recognized from that date;



(ii) goodwill or any gain recognized shall be adjusted by an amount equal to the adjustment to the fair value at the acquisition date of the identifiable asset, liability or contingent liability being recognized or adjusted; and (iii) comparative information presented for the periods before the initial accounting for the combination is complete shall be presented as if the initial accounting has been completed from the acquisition date.

Business combinations are accounted for using the acquisition method. The cost of an acquisition is measured as the aggregate of the consideration transferred, measured at acquisition date fair value and the amount of any NCI in the acquiree. For each business combination, the acquirer measures the NCI in the acquiree either at fair value or at the proportionate share of the acquiree's identifiable net assets. Acquisition costs incurred are expensed and included in operating expenses. When the Group acquires a business, it assesses the financial assets and liabilities assumed for appropriate classification and designation in accordance with the contractual terms, economic circumstances and pertinent conditions as at the acquisition date. This includes the separation of embedded derivatives in host contracts by the acquiree.

If the business combination is achieved in stages, the acquisition date fair value of the acquirer's previously held equity interest in the acquiree is remeasured to fair value at the acquisition date through consolidated statement of income. Any contingent consideration to be transferred by the acquirer will be recognized at fair value at the acquisition date. Subsequent changes to the fair value of the contingent consideration, which is deemed to be an asset or liability, will be recognized in accordance with PAS 39 either in consolidated statement of income or as a change to OCI. If the contingent consideration is classified as equity, it should not be remeasured until it is finally settled within equity.

Goodwill is initially measured at cost being the excess of the aggregate of the consideration transferred and the amount recognized for non-controlling interest over the net identifiable assets acquired and liabilities assumed. If this consideration is lower than the fair value of the net assets of the subsidiary acquired, the difference is recognized in consolidated statement of income.

After initial recognition, goodwill is measured at cost less any accumulated impairment losses. For the purpose of impairment testing, goodwill acquired in a business combination is, from the acquisition date, allocated to each of the Group's cash-generating units that are expected to benefit from the combination, irrespective of whether other assets or liabilities of the acquiree are assigned to those units.

Where goodwill forms part of a cash-generating unit and part of the operation within that unit is disposed of, the goodwill associated with the operation disposed of is included in the carrying amount of the operation when determining the gain or loss on disposal of the operation. Goodwill disposed of in this circumstance is measured based on the relative values of the operation disposed of and the portion of the cash-generating unit retained.

Revenue and Cost Recognition

Revenue is recognized to the extent that it is probable that the economic benefits will flow to the Group and the revenue can be reliably measured. The following specific recognition criteria must also be met before revenue is recognized:

Mining

Revenue from mining is recognized upon acceptance of the goods delivered upon which the significant risks and rewards of ownership of the goods have passed to the buyer and the amount of revenue can be measured reliably. Revenue from local and export coal sales are denominated in Philippine Peso and US Dollar, respectively.



Cost of coal includes expenses, which include directly related to the production and sale of coal such as cost of fuel and lubricants, materials and supplies, depreciation and depletion and other related costs, are recognized when incurred.

Construction Contracts

Revenue from construction contracts is recognized using the percentage-of-completion method of accounting and is measured principally on the basis of the estimated completion of a physical proportion of the contract work. Contracts to manage, supervise, or coordinate the construction activity of others and those contracts wherein the materials and services are supplied by contract owners are recognized only to the extent of the contracted fee revenue. Revenue from cost plus contracts is recognized by reference to the recoverable costs incurred during the period plus the fee earned, measured by the proportion that costs incurred to date bear to the estimated total costs of the contract.

Contract costs include all direct materials and labor costs and those indirect costs related to contract performance. Expected losses on contracts are recognized immediately when it is probable that the total contract costs will exceed total contract revenue. The amount of such loss is determined irrespective of whether or not work has commenced on the contract; the stage of completion of contract activity; or the amount of profits expected to arise on other contracts, which are not treated as a single construction contract. Changes in contract performance, contract conditions and estimated profitability, including those arising from contract penalty provisions and final contract settlements that may result in revisions to estimated costs and gross margins are recognized in the year in which the changes are determined. Profit incentives are recognized as revenue when their realization is reasonably assured.

The asset "Costs and estimated earnings in excess of billings on uncompleted contracts" represents total costs incurred and estimated earnings recognized in excess of amounts billed. The liability "Billings in excess of costs and estimated earnings on uncompleted contracts" represents billings in excess of total costs incurred and estimated earnings recognized. Contract retentions are presented as part of "Trade receivables" under the "Receivables" account in the consolidated statement of financial position.

Electricity Sales

Revenue from sale of electricity is derived from its primary function of providing and selling electricity to customers of its generated and purchased electricity. Revenue derived from the generation and/or supply of electricity is recognized based on the actual delivery of electricity as agreed upon between parties.

Cost of energy includes expenses directly related to the production and sale of electricity such as cost of coal, fuel, depreciation and other related costs. Cost of coal and fuel are recognized at the time the related coal and fuel inventories are consumed for the production of electricity. Cost of energy also includes electricity purchased from the spot market and the related market fees. It is recognized as expense when the Group receives the electricity and simultaneously sells to its customers.

Real Estate Sales

Real estate sales are generally accounted for under the full accrual method. Under this method, the gain on sale is recognized when: (a) the collectibility of the sales price is reasonably assured; (b) the earnings process is virtually complete; and (c) the seller does not have a substantial continuing involvement with the subject properties. The collectibility of the sales price is considered reasonably assured when: (a) the buyers have actually confirmed their acceptance of



the related loan applications after the same have been delivered to and approved by either the banks or other financing institutions for externally-financed accounts; or (b) the full down payment comprising a substantial portion of the contract price is received and the capacity to pay and credit worthiness of buyers have been reasonably established for sales under the deferred cash payment arrangement.

If the above criteria is not met, the deposit method is applied until all the conditions for recording a sale are met. Pending recognition of sale, cash received from buyers are presented under the “Customers’ advances and deposits” account in the liabilities section of the consolidated statement of financial position.

Cost of real estate sales is recognized consistent with the revenue recognition method applied. Cost of subdivision land and condominium units sold before the completion of the development is determined on the basis of the acquisition cost of the land plus its full development costs, which include estimated costs for future development works, as determined by the Company’s in-house technical staff.

Merchandise Sales

Revenue from merchandise sales is recognized upon delivery of the goods to and acceptance by the buyer and when the risks and rewards are passed on to the buyers.

Dividend Income

Revenue is recognized when the Group’s right to receive payment is established, which is generally when shareholders approve the dividend.

Rental Income

Rental income arising from operating leases on investment properties and construction equipment is accounted for on a straight-line basis over the lease terms.

Interest Income

Revenue is recognized as interest accrues using the effective interest method.

Operating Expenses

Operating expenses are expenses that arise in the course of the ordinary operations of the Group. These usually take the form of an outflow or depletion of assets such as cash and cash equivalents, supplies, investment properties and property, plant and equipment. Expenses are recognized in the consolidated statement of income.

Borrowing Costs

Borrowing costs directly attributable to the acquisition, construction or production of an asset that necessarily takes a substantial period of time to get ready for its intended use or sale are capitalized as part of the cost of the respective assets. All other borrowing costs are expensed in the period they occur. Borrowing costs consist of interest that an entity incurs in connection with the borrowing of funds.

The interest capitalized is calculated using the Group’s weighted average cost of borrowings after adjusting for borrowings associated with specific developments. Where borrowings are associated with specific developments, the amounts capitalized is the gross interest incurred on those borrowings less any investment income arising on their temporary investment. Interest is capitalized from the commencement of the development work until the date of practical completion. The capitalization of finance costs is suspended if there are prolonged periods when



development activity is interrupted. Interest is also capitalized on the purchased cost of a site property acquired specially for development but only where activities necessary to prepare the asset for development are in progress.

Foreign Currency Translations and Transactions

The consolidated financial statements are presented in Philippine Peso. Each entity in the Group determines its own functional currency and items included in the consolidated financial statements of each entity are measured using that functional currency.

Transactions in foreign currencies are initially recorded in the functional currency rate at the date of the transaction. Monetary assets and liabilities denominated in foreign currencies are retranslated at the functional currency closing rate at the reporting date. All differences are taken to consolidated statement of income. Non-monetary items that are measured in terms of historical cost in foreign currency are translated using the exchange rates as at the dates of initial transactions. Non-monetary items measured at fair value in a foreign currency are translated using the exchange rates at the date when the fair value was determined.

The functional currency of the Group's subsidiary and associate, Toledo Mining Corporation and ENK Plc., are London Pounds and United States Dollar, respectively. As at reporting date, the assets and liabilities of foreign subsidiaries are translated into the presentation currency of the Parent Company (the Philippine Peso) at the closing rate as at the reporting date, and the consolidated statement of income accounts are translated at monthly weighted average exchange rate. The exchange differences arising on the translation are taken directly to a separate component of equity under "Cumulative translation adjustment" account.

Upon disposal of a foreign subsidiary, the deferred cumulative amount recognized in OCI relating to that particular foreign operation is recognized in the consolidated statement of income.

Commission Expense

The Group recognizes commission expense when services are rendered by the broker. The commission expense is recognized upon receipt of down payment from the buyer comprising a substantial portion of the contract price and the capacity to pay and credit worthiness of buyers have been reasonably established for sales under the deferred cash payment arrangement.

Pension Cost

The Group has a noncontributory defined benefit retirement plan.

The net defined benefit liability or asset is the aggregate of the present value of the defined benefit obligation at the end of the reporting period reduced by the fair value of plan assets (if any), adjusted for any effect of limiting a net defined benefit asset to the asset ceiling. The asset ceiling is the present value of any economic benefits available in the form of refunds from the plan or reductions in future contributions to the plan.

The cost of providing benefits under the defined benefit plans is actuarially determined using the projected unit credit method.

Defined benefit costs comprise the following:

- Service cost
- Net interest on the net defined benefit liability or asset
- Remeasurements of net defined benefit liability or asset



Service costs which include current service costs, past service costs and gains or losses on non-routine settlements are recognized as expense in profit or loss. Past service costs are recognized when plan amendment or curtailment occurs. These amounts are calculated periodically by independent qualified actuaries.

Net interest on the net defined benefit liability or asset is the change during the period in the net defined benefit liability or asset that arises from the passage of time which is determined by applying the discount rate based on government bonds to the net defined benefit liability or asset. Net interest on the net defined benefit liability or asset is recognized as expense or income in profit or loss.

Remeasurements comprising actuarial gains and losses, return on plan assets and any change in the effect of the asset ceiling (excluding net interest on defined benefit liability) are recognized immediately in other comprehensive income in the period in which they arise. Remeasurements are not reclassified to profit or loss in subsequent periods.

Plan assets are assets that are held by a long-term employee benefit fund or qualifying insurance policies. Plan assets are not available to the creditors of the Group, nor can they be paid directly to the Group. Fair value of plan assets is based on market price information. When no market price is available, the fair value of plan assets is estimated by discounting expected future cash flows using a discount rate that reflects both the risk associated with the plan assets and the maturity or expected disposal date of those assets (or, if they have no maturity, the expected period until the settlement of the related obligations). If the fair value of the plan assets is higher than the present value of the defined benefit obligation, the measurement of the resulting defined benefit asset is limited to the present value of economic benefits available in the form of refunds from the plan or reductions in future contributions to the plan.

The Group's right to be reimbursed of some or all of the expenditure required to settle a defined benefit obligation is recognized as a separate asset at fair value when and only when reimbursement is virtually certain.

Termination Benefit

Termination benefits are employee benefits provided in exchange for the termination of an employee's employment as a result of either an entity's decision to terminate an employee's employment before the normal retirement date or an employee's decision to accept an offer of benefits in exchange for the termination of employment.

A liability and expense for a termination benefit is recognized at the earlier of when the entity can no longer withdraw the offer of those benefits and when the entity recognizes related restructuring costs. Initial recognition and subsequent changes to termination benefits are measured in accordance with the nature of the employee benefit, as either post-employment benefits, short-term employee benefits, or other long-term employee benefits.

Employee Leave Entitlement

Employee entitlements to annual leave are recognized as a liability when they are accrued to the employees. The undiscounted liability for leave expected to be settled wholly before twelve months after the end of the annual reporting period is recognized for services rendered by employees up to the end of the reporting period.



Leases

The determination of whether an arrangement is, or contains, a lease is based on the substance of the arrangement at inception date whether the fulfillment of the arrangement is dependent on the use of a specific asset or assets or the arrangement conveys a right to use the asset. A reassessment is made after inception of the lease only if one of the following applies:

- (a) There is a change in contractual terms, other than a renewal or extension of the arrangement;
- (b) A renewal option is exercised or extension granted, unless the term of the renewal or extension was initially included in the lease term;
- (c) There is a change in the determination of whether fulfillment is dependent on a specified asset;
or
- (d) There is substantial change to the asset.

Where a reassessment is made, lease accounting shall commence or cease from the date when the change in circumstances gave rise to the reassessment for scenarios (a), (c), or (d) and at the date of renewal or extension period for scenario (b).

Group as a Lessee

Finance leases that transfer substantially all the benefits incidental to ownership of the leased item to the Group are capitalized at the commencement of the lease at fair value of the leased property or if lower, the present value of the minimum lease payments. Lease payments are apportioned between finance charges and reduction of the leased liability so as to achieve a constant rate of interest in the remaining balance of the liability. Finance charge are recognized in finance costs in the consolidated statements of income.

A leased asset is depreciated over the useful life of the asset. However, if there is no reasonable certainty that the earnings will obtain ownership by the end of the lease term, the asset is depreciated over the shorter of the EUL of the asset and the lease term.

Operating lease payments are recognized as an expense in the consolidated statement of income on a straight basis over the lease term.

Group as a Lessor

Leases where the Group retains substantially all the risks and benefits of ownership of the asset are classified as operating leases. Initial direct costs incurred in negotiating an operating lease are added to the carrying amount of the leased asset and recognized over the lease term on the same bases as rental income.

Income Taxes

Current Income Tax

Current income tax assets and liabilities for the current and prior periods are measured at the amount expected to be recovered from or paid to the taxation authorities. The tax rates and tax laws used to compute the amount are those that are enacted or substantively enacted at the reporting date.

Deferred Tax

Deferred tax is provided, using the liability method, on all temporary differences, with certain exceptions, at the reporting date between the tax bases of assets and liabilities and their carrying amounts for financial reporting purposes.



Deferred tax liabilities are recognized for all taxable temporary differences with certain exception. Deferred tax assets are recognized for all deductible temporary differences, carryforward benefit of unused tax credits from excess minimum corporate income tax (MCIT) over the regular corporate income tax (RCIT) and net operating loss carryover (NOLCO), to the extent that it is probable that taxable income will be available against which the deductible temporary differences and carryforward benefits of unused tax credits from MCIT and NOLCO can be utilized.

Deferred tax liabilities are not provided on nontaxable temporary differences associated with investments in domestic associates and investments in joint ventures.

The carrying amount of deferred tax assets is reviewed at each reporting date and reduced to the extent that it is no longer probable that sufficient taxable income will be available to allow all or part of the deferred tax assets to be utilized. Unrecognized deferred tax assets are reassessed at each reporting date and are recognized to the extent that it has become probable that future taxable income will allow all or part of the deferred tax assets to be recovered.

Deferred tax assets and liabilities are measured at the tax rate that is expected to apply to the period when the asset is realized or the liability is settled, based on tax rate and tax laws that have been enacted or substantially enacted at the financial reporting date. Movements in the deferred income tax assets and liabilities arising from changes in tax rates are charged against or credited to income for the period.

Deferred tax assets and deferred tax liabilities are offset if a legally enforceable right exists to set off current tax assets against current tax liabilities and the deferred tax assets relate to the same taxable entity and the same taxation authority.

For periods where the income tax holiday (ITH) is in effect, no deferred taxes are recognized in the consolidated financial statements as the ITH status of the subsidiary neither results in a deductible temporary difference or temporary taxable difference. However, for temporary differences that are expected to reverse beyond the ITH, deferred taxes are recognized.

Earnings Per Share

Basic earnings per share (EPS) is computed by dividing the net income for the year attributable to common shareholders (net income for the period less dividends on convertible redeemable preferred shares) by the weighted average number of common shares issued and outstanding during the year and adjusted to give retroactive effect to any stock dividends declared during the period.

Diluted EPS is computed by dividing the net income for the year attributable to common shareholders by the weighted average number of common shares outstanding during the year adjusted for the effects of dilutive convertible redeemable preferred shares. Diluted EPS assumes the conversion of the outstanding preferred shares. When the effect of the conversion of such preferred shares is anti-dilutive, no diluted EPS is presented.

Operating Segment

The Group's operating businesses are organized and managed separately according to the nature of the products and services provided, with each segment representing a strategic business unit that offers different products and serves different markets. The Group generally accounts for intersegment revenues and expenses at agreed transfer prices. Income and expenses from discontinued operations are reported separate from normal income and expenses down to the level of income after taxes. Financial information on operating segments is presented in Note 35 to the consolidated financial statements.



Provisions

General

Provisions are recognized only when the Group has: (a) a present obligation (legal or constructive) as a result of a past event; (b) it is probable that an outflow of resources embodying economic benefits will be required to settle the obligation; and (c) a reliable estimate can be made of the amount of the obligation. If the effect of the time value of money is material, provisions are determined by discounting the expected future cash flows at a pre-tax rate that reflects current market assessments of the time value of money and, where appropriate, the risks specific to the liability. Where discounting is used, the increase in the provision due to the passage of time is recognized as an interest expense. Provisions are reviewed at each reporting date and adjusted to reflect the current best estimate.

Provision for Decommissioning and Site Rehabilitation Costs

The Group records the present value of estimated costs of legal and constructive obligations required to restore operating locations in the period in which the obligation is incurred. The nature of these restoration activities includes dismantling and removing structures, rehabilitating mines and tailings dams, dismantling operating facilities, closure of plant and waste sites, and restoration, reclamation and re-vegetation of affected areas.

The obligation generally arises when the asset is installed or the ground environment is disturbed at the production location. When the liability is initially recognized, the present value of the estimated cost is capitalized by increasing the carrying amount of the related mining assets. Over time, the discounted liability is increased for the change in present value based on the discount rates that reflect current market assessments and the risks specific to the liability. The periodic unwinding of the discount is recognized in the consolidated statements of comprehensive income as a finance cost. Additional disturbances or changes in rehabilitation costs will be recognized as additions or charges to the corresponding assets and rehabilitation liability when they occur. For closed sites, changes to estimated costs are recognized immediately in the consolidated statement of income.

Contingencies

Contingent liabilities are not recognized in the consolidated financial statements. These are disclosed unless the possibility of an outflow of resources embodying economic benefits is remote. Contingent assets are not recognized but are disclosed in the consolidated financial statements when an inflow of economic benefits is probable.

Events After the Reporting Period

Post year-end events up to the date of the auditors' report that provide additional information about the Group's position at reporting date (adjusting events) are reflected in the consolidated financial statements. Any post year-end events that are not adjusting events are disclosed in the consolidated financial statements when material.

3. Significant Accounting Judgments and Estimates

The preparation of the consolidated financial statements in conformity with PFRS requires the Group to make estimates and assumptions that affect the reported amounts of assets, liabilities, income and expenses and disclosure of contingent assets and contingent liabilities. Future events may occur which will cause the assumptions used in arriving at the estimates to change. The effects of any change in estimates are reflected in the consolidated financial statements, as they become reasonably determinable.



Judgments and estimates are continually evaluated and are based on historical experience and other factors, including expectations of future events that are believed to be reasonable under the circumstances. Actual results could differ for such estimates.

Judgments

In the process of applying the Group's accounting policies, management has made the following judgments, apart from those involving estimations which have the most significant effect on the amounts recognized in the consolidated financial statements:

Real Estate Revenue Recognition

Selecting an appropriate revenue recognition method for a real estate sale transaction requires certain judgments based on buyer's commitment on sale which may be ascertained through the significance of the buyer's initial payments and completion of development. The buyers' commitment is evaluated based on collections, credit standing on buyers and location of property. Completion of project development is determined on engineer's judgment and estimates on the physical portion of contract work done and that development is beyond the preliminary stage.

Collectibility of the Sales Price

In determining whether the sales prices are collectible, the Group considers that initial and continuing investments by the buyer of about 15% would demonstrate the buyer's commitment to pay.

Impairment of AFS Financial Assets

The Group follows the guidance of PAS 39 in determining when an asset is impaired. This determination requires significant judgment. In making this judgment, the Group evaluates, among other factors, the duration and extent to which the fair value of an investment is less than its cost; the financial health of and near-term business outlook of the investee, including factors such as normal volatility in share price for quoted equity securities and industry and sector performance, changes in technology and operational and financing cash flow for unquoted equity securities.

Financial Assets not Quoted in an Active Market

The Group classifies financial assets by evaluating, among others, whether the asset is quoted or not in an active market. Included in the evaluation on whether a financial asset is quoted in an active market is the determination on whether quoted prices are readily and regularly available, and whether those prices represent actual and regularly occurring market transactions on an arm's length basis.

Exploration and Evaluation Expenditure

The application of the Group's accounting policy for exploration and evaluation expenditure requires judgment to determine whether future economic benefits are likely, from either future exploitation or sale, or whether activities have not reached a stage that permits a reasonable assessment of the existence of reserves.

Stripping Costs

The Group incurs waste removal costs (stripping costs) during the development and production phases of its surface mining operations. During the production phase, stripping costs (production stripping costs) can be incurred both in relation to the production of inventory in that period and the creation of improved access and mining flexibility in relation to ore to be mined in the future. The former are included as part of the costs of inventory, while the latter are capitalized as a



stripping activity asset, where certain criteria are met. Significant judgment is required to distinguish between development stripping and production stripping and to distinguish between the production stripping that relates to the extraction of inventory and what relates to the creation of a stripping activity asset.

Once the Group has identified its production stripping for each surface mining operation, it identifies the separate components of the coal bodies for each of its mining operations. An identifiable component is a specific volume of the coal body that is made more accessible by the stripping activity. Significant judgment is required to identify and define these components, and also to determine the expected volumes of waste to be stripped and coal body to be mined in each of these components. These assessments are undertaken for each individual mining operation based on the information available in the mine plan. The mine plans and, therefore, the identification of components, will vary between mines for a number of reasons. These include, but are not limited to, the type of commodity, the geological characteristics of the coal body, the geographical location and/or financial considerations.

Judgment is also required to identify a suitable production measure to be used to allocate production stripping costs between inventory and any stripping activity asset(s) for each component. The Group considers that the ratio of the expected volume of waste to be stripped for an expected volume of ore to be mined for a specific component of the coal body, is the most suitable production measure.

Furthermore, judgments and estimates are also used to apply the units of production method in determining the depreciable lives of the stripping activity asset.

Classification of Property as Investment Property or Real Estate Inventories

The Group determines whether a property is classified as investment property or inventory property as follows:

- Investment property comprises land and buildings (principally offices, commercial and retail property) which are not occupied substantially for use by, or in the operations of, the Group, nor for sale in the ordinary course of business, but are held primarily to earn rental income and capital appreciation.
- Inventory comprises property that is held for sale in the ordinary course of business. Principally, this is residential, commercial and industrial property that the Group develops and intends to sell before or on completion of construction.

Distinction between Investment Properties and Owner-Occupied Properties

The Group determines whether a property qualifies as an investment property. In making its judgment, the Group considers whether the property generates cash flows largely independent of the other assets held by an entity. Owner-occupied properties generate cash flows that are attributable not only to property but also to the other assets used in the production or supply process.

Some properties comprise a portion that is held to earn rentals or for capital appreciation and another portion that is held for use in the production or supply of goods or services or for administrative purposes. If these portions cannot be sold separately, the property is accounted for as an investment property only if an insignificant portion is held for use in the production or supply of goods or services or for administrative purposes. Judgment is applied in determining whether ancillary services are so significant that a property does not qualify as investment property. The Group considers each property separately in making its judgment.



Property Acquisitions or Business Combinations

The Group acquires subsidiaries that own real estate. At the time of acquisition, the Group considers whether the acquisition represents the acquisition of a business. The Group accounts for an acquisition as a business combination where an integrated set of activities is acquired in addition to the property. More specifically, consideration is made of the extent to which significant processes are acquired and, in particular, the extent of ancillary services provided by the subsidiary (e.g., maintenance, cleaning, security, bookkeeping, hotel services, etc.). The significance of any process is judged with reference to the guidance in PAS 40 on ancillary services.

When the acquisition of subsidiaries does not represent a business, it is accounted for as an acquisition of a group of assets and liabilities. The cost of the acquisition is allocated to the assets and liabilities acquired based upon their relative fair values, and no goodwill or deferred tax is recognized.

The following transactions represent acquisitions of business with reference to the guidance in PFRS 3. The Group considered the elements acquired in the context of a mining business which include the mineral interest and rights (inputs), the subcontracting activities (processes) by which the Group access assets to enjoy the benefits and nickel laterite ore and the capacity to provide returns to the owners (outputs).

Parent Company

In 2012, the Parent Company acquired existing shares of ENK Plc, a mining company with significant mining assets in the Philippines. ENK is a laterite development and production company focused on developing its Acoje project in the Philippines. The total acquisition cost amounted to ₱2.1 billion. In aggregate, the Parent Company owns 157.26 million shares which represent 60.00% ownership in ENK Plc. The remaining 40% is owned by D&A Income Ltd, an entity from United Kingdom. The investment in ENK is accounted for as an acquisition of a business.

DMCI Mining

On October 23, 2012, DMC acquired 17% stake of Daintree Resources Limited in TMC for GBP 3.4 million. In 2013, DMC increased its interest in TMC by acquiring additional shares through a mandatory cash offer to TMC's shareholders. As of December 31, 2013, DMC holds 49,148,335 shares and voting rights representing 98.09% of voting rights. DMC is a 100% owned subsidiary of the Parent Company. The investment in TMC is accounted for as an acquisition of a business.

On December 31, 2012, DMCI Mining purchased from TMC 775,000 issued common shares or 31% ownership in Nickeline Resources Holdings Inc. (NRHI). Total acquisition cost amounted to ₱268.93 million. The investment in NRHI is accounted for as an acquisition of a business.

Evaluation and Reassessment of Control

The Group has investees that are majority owned but are not controlled (see Note 11). The Group refers to the guidance in PFRS 10 when determining whether the Group controls an investee. Particularly, the Group controls an investee when it is exposed, or has rights, to variable returns from its involvement with the investee and has the ability to affect those returns through its power over the investee. The Group considers the purpose and design of the investee, its relevant activities and how decisions about those activities are made and whether the rights give it the current ability to direct the relevant activities.



The Group controls an investee if and only if it has all the following:

- a. power over the investee;
- b. exposure, or rights, to variable returns from its involvement with the investee; and
- c. the ability to use its power over the investee to affect the amount of the investor's returns.

The Group reviewed its existing arrangements with other investors over these majority owned entities and has determined that it does not control the entities because: (a) it only allows the investor to exercise significant influence or (b) parties to the arrangement exercise joint control as significant strategic and operating decisions relating to the relevant activities of the investees require the unanimous consent of both parties.

Operating Lease Commitments - Group as Lessee

The Group has entered into various leases for its occupied offices and mining and transportation equipment. The Group has determined that all significant risks and rewards of ownership are retained by the respective lessors on the offices and equipment it leases under operating leases.

Operating Lease Commitments - Group as Lessor

The Group has entered into property lease agreements on its investment property portfolio. The Group has determined that it retains all the significant risks and rewards of ownership of these properties as the Group considered, among others, the length of the lease term compared with the estimated life of the assets.

In determining whether a lease contract is cancellable or not, the Group considered, among others, the significance of the penalty including the economic consequence to the lessee.

Finance Lease Commitments - Group as Lessee

The Group has entered into finance leases on some of its construction equipment and service vehicle. The Group has determined, based on an evaluation of the terms and conditions of the arrangements, that the lessor transfers substantially all the risks and benefits incidental to ownership of the leased equipment to the Group thus, it recognized these leases as finance leases.

Management's Use of Estimates

The key assumptions concerning the future and other sources of estimation uncertainty at the reporting date that have a significant risk of causing a material adjustment to the carrying amounts of assets and liabilities within the next financial year are discussed below.

Revenue Recognition

The Group's revenue recognition policies require use of estimates and assumptions that may affect the reported amounts of revenue and receivables.

a.) Mining

The Group's sales arrangement with its customers includes reductions of invoice price to take into consideration charges for penalties and bonuses. These price adjustments depend on the estimated quality of the delivered coal. These estimates are based on final coal quality analysis on delivered coal using American Standards for Testing Materials (ASTM).

There is no assurance that the use of estimates may not result in material adjustments in future periods. Revenue from mining amounted to ₱12,838.47 million, ₱16,373.20 million and ₱18,682.23 million in 2013, 2012 and 2011, respectively.



b.) Construction contracts

The Group's revenue from construction contracts are recognized based on the percentage-of-completion, measured principally on the basis of the estimated completion of a physical proportion of the contract work and by reference to the actual cost incurred to date over the estimated total cost of the project.

There is no assurance that the use of estimates may not result in material adjustments in future periods. Revenue from construction contracts amounted to ₱14,112.68 million, ₱14,773.25 million and ₱10,277.24 million in 2013, 2012 and 2011, respectively.

c.) Real estate sales

Selecting an appropriate revenue recognition method for a particular real estate sale transaction requires certain judgments based on, among others:

- Buyer's commitment on the sale which may be ascertained through the significance of the buyer's initial investment; and
- Stage of completion of the project.

Collectibility of the Sales Price on Real Estate Sales

In determining whether the sales prices are collectible, the Group considers that initial and continuing investments by the buyer that would demonstrate the buyer's commitment to pay. The Group has set a certain percentage of collection over the total selling price in determining buyer's commitment on the sale. It is when the buyer's investment is considered adequate to meet the probability criteria that economic benefits will flow to the Group.

Evaluation of Net Realizable Value of Inventories and Land and Improvements

Inventories and land and improvements are valued at the lower of cost and NRV. This requires the Group to make an estimate of the inventories' and land and improvements' estimated selling price in the ordinary course of business, cost of completion and costs necessary to make a sale to determine the NRV. For real estate inventories and land and improvements, the Group adjusts the cost of its real estate inventories and land and improvements to net realizable value based on its assessment of the recoverability of the real estate inventories and land and improvements. In determining the recoverability of the inventories and land and improvements, management considers whether those inventories and land and improvements are damaged or if their selling prices have declined.

Likewise, management also considers whether the estimated costs of completion or the estimated costs to be incurred to make the sale have increased. In the event that NRV is lower than the cost, the decline is recognized as an expense. The amount and timing of recorded expenses for any period would differ if different judgments were made or different estimates were utilized.

Inventories carried at cost amounted to ₱21,405.48 million and ₱19,225.05 million as of December 31, 2013 and 2012, respectively. Inventories carried at NRV amounted to ₱1,766.35 million and ₱2,290.11 million as of December 31, 2013 and 2012, respectively (Note 9).



Allowance for Doubtful Accounts

The Group maintains an allowance for doubtful accounts at a level considered adequate to provide for potential uncollectible receivables. The level of this allowance is evaluated by the management on the basis of factors that affect the collectibility of the accounts. These factors include, but are not limited to, the debtors' ability to pay all amounts due according to the contractual terms of the receivables being evaluated, the length of relationship with the customer, the customer's payment behavior and known market factors. The Group reviews the age and status of receivables, and identifies accounts that are to be provided with allowances on a continuous basis. The Group provides full allowance for receivables that it deems uncollectible.

The amount and timing of recorded expenses for any period would differ if the Group made different judgments or utilized different estimates. An increase in the allowance for doubtful accounts on receivables would increase recorded operating expenses and decrease total assets.

Provision for doubtful accounts of the Group amounted to ₱443.65 million, ₱78.30 million and ₱15.18 million in 2013, 2012 and 2011, respectively (Notes 7 and 25). Receivables of the Group that were impaired and fully provided with allowance amounted to ₱545.82 million and ₱240.48 million as of December 31, 2013 and 2012, respectively (Note 7).

Stock Pile Inventory Quantities

The Group estimates the stock pile inventory of coal by conducting a topographic survey which is performed by in-house and third party surveyors. The survey is conducted on a monthly basis with a reconfirmatory survey at year end. The process of estimation involves a predefined formula which considers an acceptable margin of error of plus or minus 3%. Thus, an increase or decrease in the estimation threshold for any period would differ if the Group utilized different estimates and this would either increase or decrease the profit for the year. The coal inventory as of December 31, 2013 and 2012 amounted to ₱1,938.05 million and ₱2,346.40 million, respectively (Note 9).

NRV of Inventories

The Group reviews its inventory to assess NRV at least on a semi-annual basis. This requires the Group to make an estimate of the inventories' estimated selling price in the ordinary course of business and costs necessary to make a sale to determine the NRV. The amount and timing of recorded expenses for any period would differ if different judgments were made or different estimates were utilized. An increase in reserves for inventory write-down would increase recorded operating expenses and decrease current assets.

Inventories of the Group at NRV, net of allowance for inventory obsolescence amounting ₱57.41 million and ₱53.27 million as of December 31, 2013 and 2012, respectively, amounted to ₱23,171.83 million and ₱21,515.16 million as of December 31, 2013 and 2012, respectively (Note 9).

Estimating Decommissioning and Site Rehabilitation Costs

The Group is legally required to fulfill certain obligations under its ECC issued by DENR when it abandons depleted mine pits. These costs are accrued based on in-house estimate, which incorporates estimates of the amount of obligations and interest rates, if appropriate. The Group recognizes the present value of the liability for these obligations and capitalizes the present value of these costs as part of the balance of the related property, plant and equipment accounts, which are being depreciated, depleted and amortized on a straight line basis over the EUL of the related asset or the lease term. Assumptions used to compute the decommissioning and site rehabilitation costs are reviewed and updated annually.



The amount and timing of the recorded obligations for any period would differ if different judgments were made or different estimates were utilized. An increase in decommissioning and site rehabilitation costs would increase the recorded operating expenses and increase noncurrent liabilities.

As of December 31, 2013 and 2012, the provision for decommissioning and site rehabilitation amounted to ₱196.50 million and ₱62.45 million, respectively (Note 20).

Estimating Useful Lives of Investment Properties, Property, Plant and Equipment and Intangible Assets

The Group estimated the useful lives of its property, plant and equipment, investment properties and intangible asset based on the period over which the assets are expected to be available for use. The estimated useful lives of property, plant and equipment, investment properties and intangible assets are reviewed at least annually and are updated if expectations differ from previous estimates due to physical wear and tear and technical or commercial obsolescence on the use of these assets.

It is possible that future results of operations could be materially affected by changes in these estimates brought about by changes in factors mentioned above. A reduction in the estimated useful lives of property, plant and equipment, investment properties and intangible asset would increase depreciation, depletion and amortization expense and decrease noncurrent assets.

In 2013, management has determined that components of its Unit II of its power plant will have to be dismantled and repaired in the first quarter of 2014. These components have original remaining lives of 2-15 years in the books. Because of the planned activity, management has accelerated the depreciation of these components and recognized an additional depreciation of ₱1.11 billion in 2013.

The Group incurred a loss from property, plant and equipment writedown due to the replacement of generation units and retirement of mining equipment amounting to ₱443.35 million and ₱341.15 million in 2013 and 2012, respectively (see Note 13).

The carrying value of property, plant and equipment of the Group amounted to ₱31,271.25 million and ₱25,724.23 million as of December 31, 2013 and 2012, respectively (Note 13). The carrying value of investment properties of the Group amounted to ₱270.18 million and ₱276.45 million as of December 31, 2013 and 2012, respectively (Note 12). The carrying value of software cost of the Group amounted to ₱33.60 million and ₱49.95 million, respectively (Note 14).

Impairment of Nonfinancial Assets

The Group assesses the impairment of assets whenever events or changes in circumstances indicate that the carrying amount of an asset may not be recoverable. The factors that the Group considers important which could trigger an impairment review include the following:

- significant underperformance relative to expected historical or projected future operating results;
- significant changes in the manner of use of the acquired assets or the strategy for overall business; and
- significant negative industry or economic trends.



An impairment loss is recognized whenever the carrying amount of an asset exceeds its recoverable amount. The recoverable amount is the higher of an asset's net selling price and value in use. The net selling price is the amount obtainable from the sale of an asset in an arm's length transaction while value in use is the present value of estimated future cash flows expected to arise from the continuing use of an asset and from its disposal at the end of its useful life. Recoverable amounts are estimated for individual assets or, if it is not possible, for the cash-generating unit to which the asset belongs.

In determining the present value of estimated future cash flows expected to be generated from the continued use of the assets, the Group is required to make estimates and assumptions that can materially affect the consolidated financial statements.

As of December 31, 2013 and 2012, the balances of the Group's nonfinancial assets, net of accumulated depreciation, depletion and amortization and accumulated provisions for impairment losses follow:

	2013	2012
Property, plant and equipment (Note 13)	₱31,271,246	₱25,724,232
Investments in associates, jointly controlled entities and others (Note 11)	11,883,288	14,369,254
Investment properties (Note 12)	270,175	276,447
Software cost - net (Note 14)	33,598	49,945

Deferred Tax Assets

The Group reviews the carrying amounts of deferred taxes at each reporting date and reduces deferred tax assets to the extent that it is no longer probable that sufficient taxable income will be available to allow all or part of the deferred tax assets to be utilized. However, there is no assurance that the Group will generate sufficient taxable income to allow all or part of deferred tax assets to be utilized.

The net deferred tax assets amounted to ₱197.60 million and ₱23.22 million as of December 31, 2013 and 2012, respectively. The unrecognized deferred tax assets of the Group amounted to ₱171.06 million and ₱142.78 million as of December 31, 2013 and 2012, respectively (Note 29).

Estimating Pension Obligation and Other Retirement Benefits

The cost of defined benefit pension plans and other employee benefits as well as the present value of the pension obligation are determined using actuarial valuations. The actuarial valuation involves making various assumptions. These include the determination of the discount rates, future salary increases, mortality rates and future pension increases. Due to the complexity of the valuation, the underlying assumptions and its long-term nature, defined benefit obligations are highly sensitive to changes in these assumptions. All assumptions are reviewed at each reporting date. The pension liabilities as at December 31, 2013 and 2012 and January 1, 2012 amounted to ₱93.77 million, ₱86.35 million and ₱75.90 million, respectively (Note 23). Pension assets amounted to ₱796.72 million, ₱684.79 million and ₱518.02 million as of December 31, 2013 and 2012 and January 1, 2012, respectively.

In determining the appropriate discount rate, management considers the interest rates of government bonds that are denominated in the currency in which the benefits will be paid, with extrapolated maturities corresponding to the expected duration of the defined benefit liability. Future salary increases are based on expected future inflation rates and other relevant factors.



The mortality rate is based on publicly available mortality tables for the specific country and is modified accordingly with estimates of mortality improvements. Future salary increases and pension increases are based on expected future inflation rates.

Contingencies

The Group is currently involved in various legal proceedings. The estimate of the probable costs for the resolution of these claims has been developed in consultation with outside counsel handling the defense in these matters and is based upon an analysis of potential results. The Group currently does not believe these proceedings will have a material effect on the Group's financial position. It is possible, however, that future results of operations could be materially affected by changes in the estimates or in the effectiveness of the strategies relating to these proceedings (Note 37).

Fair Value of Financial Instruments

The Group carries certain financial assets and liabilities at fair value, which requires extensive use of accounting estimates and judgment. While significant components of fair value measurement were determined using verifiable objective evidence (i.e., foreign exchange rates, interest rates), the amount of changes in fair value would differ if the Group utilized different valuation methodology. Any changes in fair value of these financial assets and liabilities would affect directly the consolidated statements of income and changes in equity.

Financial assets carried at fair value as of December 31, 2013 and 2012 amounted to ₱73.15 million and ₱71.26 million, respectively (Note 36).

4. Cash and Cash Equivalents

This account consists of:

	2013	2012
Cash on hand and in banks	₱8,079,962	₱2,875,761
Cash equivalents	16,694,533	6,841,281
	₱24,774,495	₱9,717,042

Cash in banks earns interest at the respective bank deposit rates. Cash equivalents are short-term placements made for varying periods of up to three (3) months depending on the immediate cash requirements of the Group, and earn annual interest ranging from 0.02% to 4.63% and 0.50% to 4.63% in 2013 and 2012, respectively.

Total finance income earned on cash in banks and cash equivalents amounted to ₱311.42 million, ₱355.02 million and ₱416.91 million in 2013, 2012 and 2011, respectively (Note 26).

5. Financial Asset at FVPL

This account consist of peso-denominated investments in quoted equity securities of San Miguel Pure Foods Company, Inc. acquired in 2011 with yields ranging from 1.90% to 1.96% as of December 31, 2013 and 2012, respectively. The investment is acquired for the purpose of selling it in the near term.



Unrealized market gain recognized in 2013 and 2011 amounted to ₱1.89 million and ₱1.40 million, respectively. Unrealized market loss recognized in 2012 amounted to ₱0.14 million. Dividends earned amounting to ₱4.29 million, ₱5.68 million and ₱4.55 million in 2013, 2012 and 2011, respectively, are included in "Other income - net" account in the consolidated statements of income (Note 28).

6. Available-for-Sale Financial Assets

This account consists of:

	2013	2012
Quoted securities		
At beginning of year	₱57,914	₱59,271
Adjustments	(5,608)	-
Disposals	-	(1,357)
At end of year	52,306	57,914
Unrealized gain recognized in equity	6,894	28,910
	59,200	86,824
Unquoted securities - at cost		
Acquisition costs	27,980	27,980
Less allowance for probable loss	26,251	26,251
	1,729	1,729
	60,929	88,553
Less noncurrent AFS - net	950	-
	₱59,979	₱88,553

Quoted securities

The quoted equity investments include investments in golf and sports club shares. Movements in the unrealized gain follow:

	2013	2012
Balance at beginning of year	₱28,910	(₱1,090)
Unrecognized gains (losses) recognized in other comprehensive income	(22,016)	30,000
Balance at end of year	₱6,894	₱28,910

Unquoted securities

This account consists of investments in stock accounted for at cost. As of December 31, 2013 and 2012, details of this account follow:

	2013	2012
Montecito Properties, Inc.	₱-	₱220,214
Less: Disposals	-	220,214
Montecito Properties, Inc.	-	-
Others	27,980	27,980
	27,980	27,980
Less allowance for impairment losses	26,251	26,251
	₱1,729	₱1,729



The unquoted shares include investment in Montecito Properties, Inc. (Montecito), a 30% owned company carried at cost less provision for impairment losses. The Group does not have significant influence in this investment.

As of December 31, 2011, the Group has changed its intention and planned to hold the investment in Montecito for more than a year, thus, reclassified as noncurrent. Current portion of AFS financial assets are expected to be sold within twelve months after the date of the consolidated statement of financial position.

As of December 31, 2012, the Group disposed all investments in Montecito with carrying amount of ₱173.26 million resulting to a loss of ₱0.99 million.

As of December 31, 2012, the remaining unquoted securities include investment in Project Quest Corporation, Universal Rightfield Property Holdings, Inc., Celebrity Sports Plaza, Inc. and Unicorn First Properties Inc. with an aggregate cost of ₱26.25 million. These investments had been fully provided for with allowance for doubtful accounts as management assessed that commitments in these shares of stock are not recoverable.

In 2011, ₱6.67 million of the Group's investment was returned. Allowance for probable loss amounting ₱6.67 million has been reversed resulting to an income of the same amount recognized under "Other income - net" (Note 28).

7. Receivables

This account consists of:

	2013	2012
Trade:		
Real estate	₱10,746,650	₱7,831,097
Electricity sales	3,754,529	2,756,622
General construction (including retention receivables on uncompleted contracts of ₱2,507.21 million in 2013 and ₱852.42 million in 2012)	3,514,152	4,079,450
Mining	2,248,668	1,453,964
Merchandising and others	73,054	67,157
	20,337,053	16,188,290
Receivables from related parties (Note 21)	131,596	187,296
Advances to officers and employees	40,695	60,048
Other receivables	184,340	482,927
	20,693,684	16,918,561
Less allowance for doubtful accounts	545,817	240,477
	20,147,867	16,678,084
Less noncurrent receivables - net	5,186,785	5,242,743
	₱14,961,082	₱11,435,341



Receivables amounting ₱545.82 million and ₱240.48 million as of December 31, 2013 and 2012, respectively, were impaired and fully provided with allowance (Note 25). Reversals of allowance for doubtful accounts amounting ₱138.31 million and ₱9.55 million pertain to other receivables and receivables from electricity sales which were assessed to be collectible or were already collected in 2013 and 2012, respectively.

Movements in the allowance for impairment losses are as follows (amounts in thousands):

2013

	Trade Receivables					Total
	Real Estate	General Construction	Mining	Electricity Sales	Others	
At January 1	₱-	₱6,788	₱-	₱130,423	₱103,266	₱240,477
Provision during the year (Note 25)	-	-	29,743	384,289	29,618	443,650
Reversal (Note 25)	-	-	-	(8,174)	(130,136)	(138,310)
At December 31	₱-	₱6,788	₱29,743	₱506,538	₱2,748	₱545,817

2012

	Trade Receivables					Total
	Real Estate	General Construction	Mining	Electricity Sales	Others	
At January 1	₱-	₱6,788	₱-	₱53,524	₱111,420	₱171,732
Provision during the year (Note 25)	-	-	-	76,899	1,398	78,297
Reversal (Note 25)	-	-	-	-	(9,552)	(9,552)
At December 31	₱-	₱6,788	₱-	₱130,423	₱103,266	₱240,477

Trade Receivables

Real estate

Real estate receivables principally consist of amounts arising from sale of residential units and subdivision land for sale and development which are collectible within ten (10) years with interest rates ranging from 9.00% to 19.00%. The corresponding titles to the subdivision units sold under this arrangement are transferred to the buyers only upon full payment of the contract price.

The Group is liable to local commercial banks relative to the discounting of real estate receivables. The purchase agreements provide that the Group should substitute defaulted contracts to sell with other contracts to sell of equivalent value. The carrying value of real estate receivables discounted amounted to ₱1.06 billion and ₱5.57 billion as of December 31, 2013 and 2012, respectively (Note 19). The range of interest for this type of loan ranges from 5.25% to 5.75%. The installment contracts receivable on a without recourse basis are used as collateral for the bank loans obtained.

The Group retains the assigned receivables in the “real estate receivables” account and records the proceeds from sales as bank loans (Note 19).

The Group entered into an agreement with Banco de Oro (BDO) for the sale of receivables on a without recourse basis. Total carrying value of installment contracts receivable sold on a without recourse basis amounted to ₱1,520.00 million as of December 31, 2012 while there is no such transaction in 2013. Under a without recourse basis, the related installment contracts receivable were derecognized from the books.



General construction

General construction receivables principally consist of receivables from third-party construction projects. These are normally collected on a 30 to 60 day term. Retention receivable pertains to the part of the contract which the contract owner retains as security and shall be released after the period allotted as indicated in the contract for the discovery of defects and other non-compliance from the specifications indicated.

Mining

Receivable from mining pertains to receivables from the sale of coal and nickel ore both to domestic and international markets. These receivables are noninterest-bearing and generally have 30-45 days credit terms.

Electricity sales

Receivables from electricity sales are claims from power distribution companies for supply and distribution of contracted energy and are generally carried at original invoice amounts less discounts and rebates. These generally have 30-day credit terms.

Merchandising and others

Receivable from merchandise sales and others pertains to receivables from the sale of wires, services rendered and others to various local companies. These receivables are noninterest-bearing and generally have 30-60 days credit terms.

Advances to Officers and Employees

Receivables from employees pertain to salary and other loans granted to the Group's employees that are collectible through salary deduction. These are non-interest bearing and are due within one year.

Other Receivables

Other receivables include the Group's receivables from JV partners and condominium corporations. These receivables are noninterest-bearing and are generally collectible within one year from the reporting date.

Noncurrent Receivables

Noncurrent receivables relate to real estate receivables arising from the sale of residential units and subdivision land for sale and development which are collectible beyond one year and within ten (10) years.

8. **Costs and Estimated Earnings in Excess of Billings on Uncompleted Contracts**

The details of the costs, estimated earnings and billings on uncompleted contracts follow:

	2013	2012
Total costs incurred	₱31,801,766	₱20,455,981
Add estimated earnings recognized	3,678,885	2,908,093
	35,480,651	23,364,074
Less total billings (including unliquidated advances from contract owners of ₱4,191.6 million in 2013 and ₱3,518.82 million in 2012)	38,175,057	25,776,707
	(₱2,694,406)	(₱2,412,633)



The foregoing balances are reflected in the consolidated statements of financial position under the following accounts:

	2013	2012
Costs and estimated earnings in excess of billings on uncompleted contracts	₱986,359	₱919,932
Billings in excess of costs and estimated earnings on uncompleted contracts	(3,680,765)	(3,332,565)
	(₱2,694,406)	(₱2,412,633)

9. Inventories

This account consists of:

	2013	2012
At Cost:		
Real estate held for sale and development	₱17,877,412	₱15,510,158
Equipment parts, materials in transit and supplies	1,542,008	1,348,078
Coal inventory	1,938,052	2,346,396
Nickel ore	48,011	20,422
	21,405,483	19,225,054
At NRV:		
Equipment parts, materials in transit and supplies - net	1,766,350	2,290,107
	₱23,171,833	₱21,515,161

Costs of equipment parts, materials in transit and supplies carried at NRV amounted to ₱1,823.76 million and ₱2,343.40 million as of December 31, 2013 and 2012, respectively.

Borrowing costs capitalized in 2013 and 2012 amounted ₱672.58 million and ₱314.34 million, respectively. The capitalization rate used to determine the amount of borrowing costs eligible for capitalization in 2013 and 2012 is 6.44% and 6.82%, respectively.

There are no real estate inventories used as collateral or pledged as security to secure liabilities.

A summary of the movement in real estate held for sale and development is set out below:

	2013	2012
Opening balance at January 1	₱15,510,158	₱12,508,114
Construction/development cost incurred	5,789,287	5,126,788
Land acquired during the year	2,484,872	1,864,014
Borrowing costs capitalized	672,582	314,337
Inventory assignment from acquisition	99,020	-

(Forward)



	2013	2012
Transfers from investment property	P25,385	P-
Transfers to property and equipment	-	(223,519)
Recognized as cost of sales (Note 24)	(6,567,151)	(4,434,929)
Other adjustment/reclassifications	(136,741)	355,353
	P17,877,412	P15,510,158

10. Other Current Assets

This account consists of:

	2013	2012
Advances to suppliers, brokers, contractors and mine rights owners	P3,233,559	P3,099,566
Other short-term investments	1,200,000	-
Input Value Added Tax (VAT)	1,169,193	804,061
Creditable taxes withheld	726,573	720,142
Prepaid expenses	352,541	408,300
Refundable deposits (Note 36)	252,353	325,859
Others	224,673	120,437
	P7,158,892	P5,478,365

Advances to Suppliers, Brokers, Contractors and Mine Rights Owners

Advances to suppliers, brokers and contractors are recouped upon every progress billing payment depending on the percentage of accomplishment. Advances to mine rights owners are noninterest-bearing and are due and demandable.

Other Short-Term Investments

Other short-term investments are time deposits with maturity of more than three (3) months from the date of acquisition and earn annual interest ranging from 1.75% to 3.75% in 2013. Interest income earned in 2013 amounted to P13.73 million presented under "Finance income" account in the consolidated statements of income (Note 26).

Input VAT

Input VAT is fully recoverable and can be applied against output VAT.

Creditable Taxes Withheld

Creditable taxes withheld are attributable to taxes withheld by third parties arising from sales and services that will be applied to future taxes payable.

Prepaid Expenses

Prepaid expenses consist mainly of prepayments for taxes, commissions, rent and insurance.

Refundable Deposits

Refundable deposits pertain to bill deposits and guaranty deposits for utilities that will be recovered within one year.

Others

Others mainly include deposits for escrow funds, bill deposits and guaranty deposits which will be recovered within one year.



11. Investments in Associates, Jointly Controlled Entities and Others

The details of the Group's investments in associates, jointly controlled entity and others follow:

	2013	2012
Acquisition cost		
Balances at beginning of year	₱6,836,841	₱4,792,652
Additions	1,029,334	2,574,805
Disposals	(3,040,555)	(530,616)
Acquisition of control on former associate	(226,899)	-
Write-off	(125)	-
Balances at end of year	4,598,596	6,836,841
Accumulated impairment loss		
Balances at beginning and end of year	(7,828)	(7,828)
Accumulated equity in net earnings		
Balances at beginning of year	7,540,241	6,083,818
Equity in net earnings	1,802,251	2,317,551
Gain on deemed disposal of investment	3,171,327	-
Dividends earned	(5,221,015)	(861,128)
Write-off	(284)	-
Balances at end of year	7,292,520	7,540,241
	₱11,883,288	₱14,369,254

The details of the Group's equity in the net assets of its associates and jointly controlled entity and the corresponding percentages of ownership follow:

	Percentages of Ownership		Equity in Net Assets	
	2013	2012	2013	2012
Associates:				
DMCI-MPIC Water Co. Inc. (DMWC)	27.19%	44.59%	₱7,600,444	₱10,828,351
Private Infra Dev Corporation (PIDC)	33.00	33.00	927,044	677,445
Nickeline Resources Holdings, Inc. (NRHI)	58.00	31.00	245,387	268,933
Subic Water and Sewerage Company, Inc. (Subic Water)	40.00	40.00	235,634	183,269
Bachy Soletanche Philippines Corporation (Bachy)	49.00	49.00	43,060	43,060
TMM Management, Inc. (TMI)	40.00	-	1,872	-
Ulugan Resources Holdings, Inc. (URHI)	30.00	-	-	-
Ulugan Nickel Corporation (UNC)	58.00	-	-	-
Berong Nickel Corporation (BNC)	56.20	-	643,452	-
Nickel Laterite Resources, Inc. (NLRI)	20.00	-	322	-
Ipilan Nickel Corporation (INC)	52.00	-	132,587	-
ENK Plc (ENK)	-	60.00	-	2,125,469
Toledo Mining Corporation (TMC)	-	17.00	-	226,899
			9,829,802	14,353,426

(Forward)



	Percentages of Ownership		Equity in Net Assets	
	2013	2012	2013	2012
Jointly Controlled Entities:				
ENK Plc. (ENK)	60.00%	–%	₱2,038,166	₱–
DMCI-First Balfour Joint Venture (DMFB)	51.00	51.00	15,320	15,419
Eco Process & Equipment Philippines, Inc. (Eco Process)	–	50.00	–	409
Total			₱11,883,288	₱14,369,254

There have been no outstanding capital commitments in 2013 and 2012. All associates and jointly controlled entities are incorporated in the Philippines except for ENK which is incorporated in London, United Kingdom.

The following table summarizes the significant financial information of the associates and jointly controlled entity that are material to the Group:

	2013			
	DMWC	Subic Water	PIDC	ENK
Statement of financial position				
Current assets	₱10,785,242	₱391,403	₱2,298,886	₱690,472
Noncurrent assets	70,003,553	1,016,358	10,759,434	3,808,951
Current liabilities	15,034,952	172,609	1,306,118	93,042
Noncurrent liabilities	35,072,814	379,855	6,940,779	662,076
Equity	30,681,029	855,297	4,811,423	3,744,305
Statement of income				
Revenue	16,895,200	542,041	67,413	271,486
Costs and expenses	10,155,479	336,865	71,961	409,351
Net income (loss)	6,739,721	205,176	(4,548)	(137,865)
	2012			
	DMWC	Subic Water	PIDC	ENK
Statement of financial position				
Current assets	₱8,110,423	₱499,671	₱5,789,319	₱883,115
Noncurrent assets	65,836,667	853,363	6,174,022	4,041,841
Current liabilities	13,539,675	199,164	1,209,930	177,454
Noncurrent liabilities	34,111,034	383,409	6,937,440	668,629
Equity	26,296,381	770,461	3,815,971	4,078,873
Statement of income				
Revenue	15,882,765	600,232	103,364	290,619
Costs and expenses	9,988,123	408,676	73,394	1,085,112
Net income (loss)	5,894,642	191,556	29,970	(794,493)

The Group's dividend income from DMWC and Subic Water amounted to ₱5,191.21 million and ₱29.71 million, respectively, in 2013. Equity in net earnings during the year from DMWC and Subic Water amounted to ₱1,832.53 million and ₱82.07 million, respectively. Equity in net losses during the year from PIDC and ENK amounted to ₱1.50 million and ₱87.30 million, respectively.



The aggregate carrying amount of the Group's individually immaterial investments in associates and jointly controlled entities in 2013 amounted to ₱1,057.58 million and nil, respectively. Equity in net losses during the year from individually immaterial associates in 2013 amounted to ₱23.55 million.

DMWC

On November 27, 2008, through a Subscription Agreement by and among the Parent Company, MPIC and DMWC, the Parent Company and MPIC subscribed to 961,600,000 common shares and 1,923,200,000 common shares, respectively, of DMWC.

Simultaneous with the execution of the Subscription Agreement, the Parent Company, DMWC, MPIC and Maynilad entered into a Shareholders' Agreement outlining the relationship of the Parent Company and MPIC as shareholders of DMWC. In the same Shareholders' Agreement, which was immediately executory, the parties confirmed that each of the Parent Company and MPIC holds, on the date of said Shareholders' Agreement, equity interests in the form of shares and share entitlements in DMWC equal to 44.59% and 55.41%, respectively.

DMWC's decrease in authorized capital stock

As approved by DMWC's BOD on August 31, 2012, DMWC decreased its authorized capital stock from ₱5,854.80 million divided into 5,854.80 million common shares with par value of ₱1.00 to 4,664.80 million common shares with par value of ₱1.00. The decrease in DMWC's authorized capital stock was approved by the SEC on October 10, 2012. The main purpose of the decrease in authorized capital stock was to settle the outstanding subscriptions payable of existing shareholders which includes the Parent Company. The share of the Parent Company, as a result of the decrease in the authorized capital stock, amounted to ₱530.62 million which is accounted for as cancellation of the Parent Company's subscription payable of ₱379.71 million and a return of a portion of its investment amounting ₱150.91 million. The ₱150.91 million was applied against the liability to DMWC (Notes 38).

Marubeni Corporation – Nippon Koei Co. Ltd (MCNK JV Corporation) and DMWC Subscription Agreement

On December 28, 2012, MCNK subscribed 169,617,682 common shares of stock of DMWC for ₱169.6 million out of which it initially paid ₱42.4 million. On the same date, the BOD of DMWC approved a resolution to increase its authorized capital stock sufficient enough to cover the issuance of the subscription shares. On January 29, 2013, the SEC approved DMWC's increase in authorized capital stock and MCNK fully paid the remaining subscription price amounting ₱127.2 million on February 13, 2013.

MCNK is 90.0% owned by Marubeni Corporation, a company incorporated in Japan and 10% owned by MAPL Holdings B.V., a company incorporated in Netherlands.

On February 13, 2013, MCNK subscribed to an additional 508,853,045 common shares of DMWC with a par value for ₱1.00 per share for a total subscription price of ₱10,200.00 million. On the same date, DMWC issued these shares and MCNK fully paid these shares.

The above transactions resulted to the dilution of the Parent Company's interest in DMWC. The dilution of interest due to subscription and issuance of DMWC shares to MCNK resulted to a dilution gain amounting to ₱3,171.33 million which was recorded as "Gain on sale of investment" in the consolidated statements of income. The gain arises from the difference between the Parent Company's share in the cash received from MCNK's subscription and the effective reduction in the share in net asset of DMWC.



Partial sale of investment in DMWC to MPIC and MCNK

On February 13, 2013 the Parent Company sold 154,992,852 shares and 472,555,019 shares held to MPIC and MCNK amounting to ₱2,376.04 million and ₱6,650.60 million, respectively. The excess of the proceeds received over the carrying value of the investment disposed amounting to ₱5,986.08 million was recorded as “Gain on sale of investment” in the consolidated statements of income.

Rollforward of the cost of investment in DMWC follows:

	2013	2012
Acquisition cost		
Balances at beginning of year	₱3,430,983	₱3,961,600
Partial sale of investments	(3,040,555)	-
Cancellation of subscription payable	-	(379,708)
Return of capital	-	(150,909)
Balances at end of year	390,428	3,430,983
Accumulated equity in net earnings		
Balance at beginning of year	7,397,368	5,989,698
Equity in net earnings	1,832,530	2,263,798
Gain on deemed disposal of investment	3,171,327	-
Dividends received	(5,191,209)	(856,128)
Balances at end of year	7,210,016	7,397,368
	₱7,600,444	₱10,828,351

The above transactions resulted to the change in effective interest in DMWC from 44.59% as of December 31, 2012 to 27.19% as of December 31, 2013.

PIDC

PIDC is primarily engaged in the business of construction, development of various infrastructure projects such as roads, highways, toll roads, freeways, skyways, flyovers, viaducts and interchanges. On February 19, 2008, PIDC was awarded the contract for the financing, design, construction, operation and maintenance of the Tarlac-Pangasinan-La Union Expressway (TPLEX).

On June 2, 2011, PIDC entered into Omnibus Loan Security Agreement (the “Omnibus Agreement”) with Banco de Oro Unibank, Inc., Development Bank of the Philippines and Land Bank of the Philippines as Lenders, the Shareholders as the Third Party Mortgagors and Sponsors, BDO Capital and Investment Corporation and Development Bank of the Philippines as Lead Arrangers, BDO Unibank, Inc., Trust and Investments Group as Facility Agent, DSRA & Paying Agent and Collateral Agent.

Breakdown of the syndicated loan is as follows:

	Amount
Banco de Oro Unibank, Inc.	₱7,125,000,000
Development Bank of the Philippines	2,375,000,000
Land Bank of the Philippines	2,000,000,000
	₱11,500,000,000



The Omnibus Agreement was entered into to finance the Project which is to design, construct, operate, and maintain Phase 1 of the Tarlac-Pangasinan-La Union Toll Expressway under the Toll Concession Agreement dated August 28, 2008, between PIDC as Grantee and, the Republic of the Philippines, acting and by through the Department of Public Works and Highways and the Toll Regulatory Board, as Grantor.

Details of the loan follow:

- a. Interest: At a floating rate per annum equivalent to the five (5) - year Philippine Dealing System Treasury-Fixing (PDST-F) benchmark yield for treasury securities as published on the PDEX page of Bloomberg (or such successor electronic service provider) at approximately 11:30a.m. (Manila Time) on the banking day prior to each day of Borrowing and with respect to the fifth (5th) year from the date of initial Borrowing and each succeeding interest period thereafter, plus 3% per annum.
- b. Repayment: The principal amount shall be payable in twenty-eight (28) quarterly installments commencing on the thirty ninth (39th) month from the initial borrowing date, inclusive of a not more than a three (3) years grace period. Final repayment date is ten (10) years after initial borrowing. The loan may be prepaid voluntarily provided the conditions in the Omnibus Agreement are satisfied.

On September 3, 2009, the BOD approved the Parent Company's additional subscription of 1,449,684 common shares out of PIDC's increase in authorized capital stock of ₱3.50 billion. In 2010 and 2013, the Parent Company paid in full the subscriptions of shares amounting ₱244.67 million and ₱251.10 million, respectively increasing the investment from ₱677.44 million to ₱927.04 million.

Subic Water

On January 22, 1997, PDI subscribed to 3,262,320 shares at the par value of ₱10 per share for an aggregate value of ₱32.62 million in Subic Water, a joint venture company among Subic Bay Metropolitan Authority (SBMA), a government-owned corporation, Olongapo City Water District, and Cascal Services Limited (a company organized under the laws of England). The agreement executed by the parties on November 24, 1996 stipulated, among others, that PDI shall have an equity participation equivalent to 40% in Subic Water amounting ₱74.80 million (based on the initial subscribed and paid-in capital of ₱187.00 million). The balance of PDI's committed subscription to Subic Water of ₱38.18 million (net of additional subscriptions payment of ₱4.00 million in 1998) is expected to be paid on or before the second anniversary of the effectivity date. As of December 31, 2013 and 2012, such committed subscription remains unpaid.

The investment in Subic Water is accounted for as an investment in an associate.

ENK Plc

In 2012, the Parent Company acquired existing shares of ENK Plc, a mining company with significant mining assets in the Philippines. ENK is a nickel laterite development and production company focused on developing its Acoje and Zambales chromite projects in the Philippines. The total acquisition cost amounted to ₱2.1 billion. In aggregate, the Parent Company owns 157.26 million shares which represents 60% ownership in ENK Plc. The remaining 40% is owned by D&A Income Ltd (D&A), an entity from United Kingdom. The investment in ENK is accounted for as an acquisition of a business.



In 2012, the Parent Company and D&A executed a Shareholders' Agreement which clearly defines the roles of the shareholders as having economic interests over ENK. The Parent Company's 60% ownership interest in ENK only allows it to exercise significant influence because of limited participation in the governance of ENK. ENK is classified as an associate of the Group and accounted for using the equity method of accounting.

On January 22, 2013, the Parent Company has acquired majority seats in the Board of ENK. Upon adoption of PFRS 10 and PFRS 11 in 2013, the Parent Company reassessed its arrangement with D&A over ENK and has determined that it has joint control over ENK because even at 60% ownership and majority seats in the Board, the strategic and financial operating decisions relating to the economic activities of ENK require the unanimous consent of both parties.

TMC

On October 23, 2012, DMCI Mining Corporation (DMC) purchased from Daintree Resources Limited 8,480,250 common shares representing 17.01% ownership in TMC for GBP 3.4 million or ₱226.90 million. TMC is an investment holding company incorporated in England and Wales on May 29, 2007 and is engaged in ore and mineral mining and exploration. TMC has strategic interests in two privately owned nickel companies in the Philippines, Berong Nickel Corporation and Ipilán Nickel Corporation.

In 2013, DMC increased its interest in TMC by acquiring additional shares through a mandatory cash offer to TMC's shareholders. As of December 31, 2013, DMC holds 49,148,335 shares and voting rights representing 98.06% of voting rights.

Delisting of TMC's shares in the London Stock Exchange (AIM)

On December 12, 2013, TMC's shareholders passed the resolution to cancel the admission of trading of TMC's ordinary shares on the AIM (delisting). The last day of dealings in ordinary shares on AIM is on December 19, 2013 while the date of cancellation of admission to trading on AIM is on December 20, 2013.

Changes in the Board composition in TMC

On December 20, 2013, DMC has acquired majority seats in the Board of TMC.

For the year ended December 31, 2012, at 17.01% ownership, TMC was considered to be an associate under the previously existing PAS 28, and was accounted for using the equity method. With the additional subscription of 81.05% and upon adoption of PFRS 10, the Group assessed that it has control over TMC. The assets, liabilities and equity of TMC have been consolidated in the financial statements of the Group on December 20, 2013, the date control has been obtained (see Note 33).

Acquisition of TMC's associates

Upon consolidation of the net assets of TMC, the Group has obtained the following investments in associates:

- a. TMM Management, Inc. (TMI)
- b. Ulugan Resources Holdings, Inc. (URHI)
- c. Ulugan Nickel Corporation (UNC)
- d. Berong Nickel Corporation (BNC)
- e. Nickel Laterite Resources, Inc. (NLRI)
- f. Ipilán Nickel Corporation (INC)



The Group assessed that its interest over these entities only allows it to exercise significant influence.

NRHI

On December 31, 2012, DMC purchased from TMC 775,000 issued common shares in NRHI for a total acquisition cost of ₱268.93 million. After purchase of shares from TMC, ownership structure in NRHI consists of 60% interest of Ulugan Resources Holdings, Inc. (URHI), 31% by DMC and 9% by TMC.

In 2013, DMC acquired additional shares in TMC. As of December 20, 2013, DMC holds 98.06% of voting rights and majority seats in the Board of TMC. After reassessment of control in accordance with PFRS 10, the Group assessed that it has control over TMC. Net assets of TMC has been consolidated in the financial statements of the Group, including its investment in NRHI. The Group's effective interest in NRHI as at December 31, 2013 represent 58% ownership.

As at December 31, 2013 and 2012, NRHI is classified as an associate of the Group and accounted for using the equity method. The Group's 58% interest over NRHI only allows it to exercise significant influence.

DMFB

On January 18, 2008, DMCI has entered into a Joint Venture Agreement with First Balfour, Inc. with 51% interest. DMFB Joint Venture, an incorporated joint venture, was formed for the construction of the Light Rail Transit (LRT) Line 1 North Extension Project (the Project). The Project was started on June 7, 2008 and was completed on October 23, 2010.

DMCI's interest in DMFB Joint Venture is a joint arrangement accounted for as joint venture using the equity method where the carrying amount of the investment is adjusted to reflect the changes in the net assets of the joint venture since the acquisition date (see Note 2).

The joint venture had no contingent liabilities or capital commitments as at December 31, 2013 and 2012.

Joint Operations

On September 13, 2012, DMCI has entered into a Joint Venture Agreement with C.M. Pancho Construction, Inc. (C.M. Pancho) to form an unincorporated JV to jointly construct, execute and develop the Philippines Secondary National Road Development Project (SNRDP) Contract Package 1. The joint arrangement is accounted for as joint operations.

In 2013, DMCI entered into joint venture agreement with C.M Pancho and J.E. Manalo & Co., Inc. (JEMCO) to form an unincorporated JV to jointly construct, execute and develop the project, Philippines Secondary National Road Development Project (SNRDP) Contract Package 1: Road Rehabilitation, Buray Junction to Barangay Tinani, Paranas, Samar KM 827+144.400 - 843 +500 awarded by Millennium Challenge Account - Philippines (MCAP). The joint arrangement is accounted for as joint operations.



12. Investment Properties

The movements in this account follow (amounts in thousands):

	2013			
	Land	Buildings and Building Improvements	Condominium Units	Total
Cost				
At January 1	₱73,181	₱201,373	₱44,347	₱318,901
Additions	–	25,939	–	25,939
Transfer to inventory	(25,385)	–	–	(25,385)
At December 31	47,796	227,312	44,347	319,455
Accumulated Depreciation and Amortization				
At January 1	–	39,941	2,513	42,454
Depreciation and amortization (Note 24)	–	3,416	3,410	6,826
At December 31	–	43,357	5,923	49,280
Net Book Value	₱47,796	₱183,955	₱38,424	₱270,175

	2012			
	Land	Buildings and Building Improvements	Condominium Units	Total
Cost				
At January 1	₱73,181	₱62,176	₱44,347	₱179,704
Additions	–	139,197	–	139,197
At December 31	73,181	201,373	44,347	318,901
Accumulated Depreciation and Amortization				
At January 1	–	36,525	1,021	37,546
Depreciation and amortization (Note 24)	–	3,416	1,492	4,908
At December 31	–	39,941	2,513	42,454
Net Book Value	₱73,181	₱161,432	₱41,834	₱276,447

The aggregate fair value as of December 31, 2013 and 2012 amounted to ₱292.87 million and ₱284.29 million, respectively. The fair value of the investment properties has been determined based on valuations performed by an accredited independent appraiser.

The value of the investment properties was arrived at using the Market Data Approach. In this approach, the value of the investment properties is based on Level 3 inputs such as sales and listings of comparable property registered in the vicinity. The technique of this approach requires the establishment of comparable property by reducing reasonable comparative sales and listings to a common denominator. This is done by adjusting the differences between the subject property and those actual sales and listings regarded as comparable. The properties used as basis of comparison are situated within the immediate vicinity of the subject property.

There have been no outstanding capital commitments in 2013 and 2012.



Rental income from investment properties (included under 'Other income') amounted to ₱84.45 million, ₱274.17 million and ₱53.81 million in 2013, 2012 and 2011, respectively (Note 28). Direct operating expenses (included under 'Cost of sales and services' in the consolidated statements of income) arising from investment properties amounted to ₱6.83 million, ₱4.91 million and ₱6.31 million in 2013, 2012 and 2011, respectively (Note 24).

There are no investment properties as of December 31, 2013 and 2012 that are pledged as security against liabilities.



13. Property, Plant and Equipment

The movements in this account follow (amounts in thousands):

	2013									
	Land and Land Improvements	Power Plant, Buildings and Building Improvements	Construction Equipment, Machinery and Tools	Office Furniture, Fixtures and Equipment	Transportation Equipment	Conventional and Continuous Mining Properties and Equipment	Leasehold Improvements	Mine Properties	Construction in Progress	Total
Cost										
At January 1	₱1,558,027	₱18,973,630	₱5,301,420	₱374,259	₱350,272	₱15,228,638	₱142,198	₱-	₱5,602,712	₱47,531,156
Additions	32,949	408,508	1,245,152	46,481	43,627	657,798	23,493	133,189	7,819,623	10,410,820
Transfers from construction in progress	461,676	2,110,515	-	-	-	-	-	-	(2,572,191)	-
Transfers and retirements/disposals	-	-	(127,728)	(2,851)	(614)	(333,349)	-	-	-	(464,542)
Writedown and impairment loss	-	(564,277)	-	-	-	-	-	-	-	(564,277)
At December 31	2,052,652	20,928,376	6,418,844	417,889	393,285	15,553,087	165,691	133,189	10,850,144	56,913,157
Accumulated Depreciation, Depletion and Amortization										
At January 1	468,281	4,042,225	3,899,344	315,689	220,930	12,783,081	77,374	-	-	21,806,924
Depreciation, depletion and amortization (Notes 24 and 25)	9,026	2,195,353	617,710	99,972	46,800	1,577,156	19,989	-	-	4,566,006
Transfers and retirements/disposals	-	-	(106,241)	(156)	(552)	(503,142)	-	-	-	(610,091)
Writedown	-	(120,928)	-	-	-	-	-	-	-	(120,928)
At December 31	477,307	6,116,650	4,410,813	415,505	267,178	13,857,095	97,363	-	-	25,641,911
Net Book Value	₱1,575,345	₱14,811,726	₱2,008,031	₱2,384	₱126,107	₱1,695,992	₱68,328	₱133,189	₱10,850,144	₱31,271,246



2012

	Land and Land Improvements	Power Plant, Buildings and Building Improvements	Construction Equipment, Machinery and Tools	Office Furniture, Fixtures and Equipment	Transportation Equipment	Conventional and Continuous Mining Properties and Equipment	Leasehold Improvements	Mine Properties	Construction in Progress	Total
Cost										
At January 1	₱1,507,723	₱19,083,577	₱4,650,906	₱327,295	₱307,786	₱14,932,108	₱137,718	₱-	₱2,081,458	₱43,028,571
Additions	50,304	73,214	878,527	46,964	71,704	1,162,314	4,480	-	3,888,992	6,176,499
Transfers from inventory (Note 9)	-	-	-	-	-	-	-	-	223,519	223,519
Transfers and retirements and disposals	-	237,538	(228,013)	-	(29,218)	(865,784)	-	-	(591,257)	(1,476,734)
Writedown	-	(420,699)	-	-	-	-	-	-	-	(420,699)
At December 31	1,558,027	18,973,630	5,301,420	374,259	350,272	15,228,638	142,198	-	5,602,712	47,531,156
Accumulated Depreciation, Depletion and Amortization										
At January 1	459,255	3,107,996	3,598,169	266,483	208,108	11,909,813	61,144	-	-	19,610,968
Depreciation, depletion and amortization (Notes 24 and 25)	9,026	1,013,782	525,853	49,206	36,831	2,092,772	16,230	-	-	3,743,700
Transfers and retirements/disposals	-	-	(224,678)	-	(24,009)	(1,219,504)	-	-	-	(1,468,191)
Writedown	-	(79,553)	-	-	-	-	-	-	-	(79,553)
At December 31	468,281	4,042,225	3,899,344	315,689	220,930	12,783,081	77,374	-	-	21,806,924
Net Book Value	₱1,089,746	₱14,931,405	₱1,402,076	₱58,570	₱129,342	₱2,445,557	₱64,824	₱-	₱5,602,712	₱25,724,232



The construction in progress accounts mostly contains purchased mining equipment items that are in transit and various buildings and structures that are under construction as of December 31, 2013 and 2012. In 2013 and 2012, construction in progress includes capitalized rehabilitation costs for Units 1 and 2 of SCPC's power plant and construction of SLPGC's 2 x 150 megawatt (MW) coal-fired thermal power plant. The rehabilitation of Unit 1 of SCPC power plant was completed in January 2013 and the rehabilitation of Unit 2 of SCPC power plant is expected to be completed in the first quarter of 2014.

The capitalized borrowing cost included in the construction in progress account amounted to ₱101.38 million and ₱11.01 million on December 31, 2013 and 2012, respectively. The average capitalization rate is 3.36% and 3.50% in 2013 and 2012 (see Note 19).

Mine properties pertain to the expected decommissioning and site rehabilitation costs of Panian minesite and dismantling of mining machineries and conveyor belts at the end of its life (see Note 20).

In 2013, 2012 and 2011, the Group sold various equipment items at a net gain included under the consolidated statements of income caption "Other income - net" amounting ₱144.86 million, ₱127.50 million and ₱57.57 million, respectively (Note 28).

As security for timely payment, discharge, observance and performance of the loan provisions, the Company creates, establishes, and constitutes in favor of the Security Trustee, for the benefit of all secured parties, a first ranking real estate and chattel mortgage on present and future real assets and chattels owned by the Company as of December 31, 2013 and 2012 (Note 19).

SCPC incurred a loss from property, plant and equipment writedown due to the replacement of generation units amounting to ₱443.35 million and ₱341.15 million in 2013 and 2012, respectively (Note 28).

The construction of the coal-fired power plant commenced on the early part of the 2012. SLPGC expects to spend ₱17.70 billion to complete the power plant in the early part of 2015.

Depreciation, depletion and amortization expense on property, plant and equipment amounted to ₱4,566.01 million, ₱3,743.70 million and ₱3,496.75 million in 2013, 2012 and 2011, respectively (Notes 24 and 25).

The cost of fully depreciated assets that are still in use as of December 31, 2013 and 2012 amounted to ₱11,422.25 million and ₱7,674.24 million, respectively.

There are no temporarily idle property, plant and equipment in 2013 and 2012.

14. Other Noncurrent Assets

The details of other noncurrent assets follow:

	2013	2012
Deferred input VAT	₱1,091,094	₱293,536
Investment in sinking fund (Note 19)	517,603	508,041

(Forward)



	2013	2012
Security deposits (Note 36)	₱407,519	₱191,390
Exploration and evaluation asset	348,153	-
Deposit for future investment	149,108	145,330
5% input VAT withheld - net	164,526	124,438
Prepaid rent (Note 37)	89,906	100,115
Software cost - net	33,598	49,945
Prepaid tax	28,993	22,807
Others	132,248	7,248
	2,962,748	1,442,850
Less current portion of prepaid rent (Note 10)	4,545	5,103
	₱2,958,203	₱1,437,747

Deferred Input VAT

This pertains to VAT incurred from acquisition of capital assets mostly coming from the ongoing construction of coal-fired power plant of SLPGC.

Investment in Sinking Fund

In a special meeting of the BOD of SCPC held on March 9, 2010, the BOD of SCPC authorized SCPC to establish, maintain, and operate trust and investment management accounts with Banco de Oro Unibank, Inc., - Trust and Investment Group (BDO) as the Security Trustee. The Omnibus Agreement provided that the Security Trustee shall invest and reinvest the monies on deposit in Collateral Accounts (Note 19). All investments made shall be in the name of the Security Trustee and for the benefit of the Collateral Accounts. In May 2010, BDO made an initial investment in the Sinking Fund amounting ₱304.81 million. As of December 31, 2013 and 2012, the investment in sinking fund amounted to ₱517.60 million and ₱508.04 million, respectively.

Interest earned from the sinking fund amounted to ₱12.17 million, ₱17.21 million and ₱7.21 million in 2013, 2012 and 2011, respectively (Note 26).

Security Deposits

Security deposits represent payments to and held by the lessor as security for the faithful and timely performance by the Group of all its obligations and compliance with all provisions of the equipment rental agreement (Note 37). These deposits shall be returned by the lessor to the Group after deducting any unpaid rental, and/or any other amounts due to the lessor for any damage and expense incurred to put the vehicle in good working condition.

Exploration and Evaluation Asset

In 2013, Semirara incurred costs related to exploratory drilling and activities in Bobog minesite amounting to ₱348.15 million.

Deposits related to Definitive Agreement with a Third Party

On October 30, 2012, DMC entered into a definitive agreement with a third party for the assignment of shares and call options in the three holding companies. The assigned shares are held by an escrow agent and the ownership is subject to a condition that all pending cases faced by the third party, the holding companies and the development companies are resolved in their favor.

The purchase price due to the third party for the total shares is \$13.20 million. In accordance with the agreement, DMC deposited a portion of the purchase price which was devoted primarily to paying the certain agreed upon expenses, including those relating to ongoing litigation of



permitting issues faced by the third party, holding companies and development companies. The deposited amount is collectible from third party in case the outcomes of litigations are unfavorable.

The definitive agreement also sets a deadline, should the pending cases remain unresolved, allows the third party to recover the shares and the Company to recover whatever was advanced.

5% Input VAT withheld - net

As a result of the enactment of RA No. 9337 effective November 1, 2005, National Power Corporation (NPC) started withholding the required 5% input VAT on the VAT exempt coal sales. On March 7, 2007, SMC obtained a ruling from the Bureau of Internal Revenue (BIR) which stated that the sale of coal remains exempt from VAT. In 2007, SMC filed a total claim for refund of ₱190.50 million from the BIR representing VAT erroneously withheld by NPC from December 2005 to March 2007, which eventually was elevated to the Court of Tax Appeals (CTA). On October 13, 2009, CTA granted SMC's petition for a refund on erroneously withheld VAT initially on December 2005 sales amounting to ₱11.85 million. The Commissioner of BIR moved for reconsideration of the CTA's Decision. On November 21, 2009, SMC filed its comment thereon. On August 10, 2010, the CTA issued a Writ of Execution on its decision dated October 13, 2009 and was served to BIR on August 13, 2010.

In 2011, the CTA rendered a decision granting the SMC's petition for refund or issuance of tax credit certificate (TCC) in the total amount of ₱178.65 million. The Commissioner of BIR filed a motion for reconsideration which was denied in a Resolution executed by the CTA. The Commissioner of BIR filed for a Petition for Review with the CTA En Banc.

In 2012, CTA En Banc rendered a decision dismissing the petition for review for the lack of merit on ₱163.36 million refund.

In 2012, management has estimated that the refund will be recovered after ten (10) to fifteen (15) years. Consequently, the claim for tax refund was provided with provision for impairment losses amounting to ₱47.15 million (Note 25).

On January 30, 2013, the Supreme Court denied the BIR Commissioner's Petition for Review. Subsequently, the latter filed a Motion for Reconsideration with the Supreme Court.

On June 19, 2013, the Supreme Court denied such petition of Motion for Consideration with finality. On September 18, 2013, Entry of Judgment was issued by the Supreme Court in GR No. 203621. On January 21, 2014, a "Notice of Resolution" was received from the Court of Tax Appeals citing that "It is appearing that the Resolution of the Supreme Court dated January 30, 2013 has already become final and executory and Entry of Judgment was already issued by the Supreme Court on September 19, 2013, herein SMC is entitled as a matter of right to a writ of execution. It, therefore, becomes the ministerial duty of CTA to issue a writ of execution".

Because of the above developments, management reassessed the timeline of collection to be in 5 years (instead of 15 years). A re-estimation of the realizable value was made by the management using discounted cash flows with the assumption of collection in 5 years and discount rate of 2.91%. This resulted to a reversal of ₱61.55 million provision for impairment loss reflected as "Other income" in the consolidated statements of income (see Note 28).



Movements in allowance for impairment losses of the 5% input VAT withheld follows:

	2013	2012
At January 1	₱87,525	₱40,374
Provision (Note 25)	–	47,151
Reversal (Note 28)	(61,549)	–
At December 31	₱25,976	₱87,525

Prepaid Rent

The Group entered into a Land Lease Agreement (LLA) with PSALM for the lease of land in which the plant is situated for a period of twenty-five (25) years. The Group paid US\$3.19 million or its peso equivalent of ₱150.57 million as payment for the 25 years of rental (Note 37).

Long term portion of the prepaid rent amounted to ₱85.36 million and ₱95.01 million as of December 31, 2013 and 2012, respectively.

Capitalized development costs

In 2013, SCI has capitalized development expenditures amounting to ₱37.96 million which is included in “Others”. Development costs for goods, commodities, wares and merchandise including potter earthenware, stoneware, bricks, tiles, roofs and other merchandise produce from clay are recognized as an intangible asset.

Software Cost

Movements in software cost account follow:

	2013	2012
At Cost		
At January 1	₱131,188	₱114,172
Additions	20,379	17,016
At December 31	151,567	131,188
Accumulated Amortization		
At January 1	81,243	53,120
Amortization (Notes 24 and 25)	36,726	28,123
At December 31	117,969	81,243
Net Book Value	₱33,598	₱49,945

Prepaid tax

Prepaid tax pertains to the current portion of the advance payment of documentary stamp tax in relation to the availments of long term borrowings during the year.

15. Short-term Debt

This account consists of the following:

	2013	2012
Acceptances and trust receipts payable	₱63,740	₱60,575
Bank loans	2,055,556	572,396
	₱2,119,296	₱632,971



Acceptances and trust receipts payable

Acceptances and trust receipts are used by the Group to facilitate payment for importations of materials, fixed assets and other assets. These are noninterest-bearing and with maturity of less than one (1) year.

Bank loans

The Group's bank loans consist of unsecured peso-denominated short-term borrowings from local banks which bear annual interest ranging from 1.17% to 4.00% in 2013 and 1.04% to 2.00% in 2012, and are payable on monthly, quarterly and lump sum bases on various maturity dates within the next twelve (12) months after the reporting date.

The Group's agreements with local banks contain some or all of the following restrictions relating to, among others: purchase of issued and outstanding capital stock; disposal of encumbered properties; change in the ownership or management and nature of its business; dividend declaration and distribution; guarantees; incurrence of additional liabilities; and merger and consolidation.

As of December 31, 2013 and 2012, the Group is in compliance with the loan covenants required by the banks. Finance costs incurred on bank loans and short term borrowings amounted to ₱126.96 million and ₱50.80 million and ₱87.09 million in 2013, 2012 and 2011, respectively (Note 27).

16. Liabilities for Purchased Land

Liabilities for purchased land represent the balance of the Group's obligations to various real estate property sellers for the acquisition of certain parcels of land. The terms of the deeds of absolute sale covering the land acquisitions provided that such obligations are payable only after the following conditions, among others, have been complied with: (a) presentation by the property sellers of the original transfer certificates of title covering the purchased parcels of land; (b) submission of certificates of non-delinquency on real estate taxes; and (c) physical turnover of the acquired parcels of land to the Group.

The outstanding balance of liabilities for purchased land as of December 31, 2013 and 2012 follow:

	2013	2012
Current	₱885,088	₱929,379
Noncurrent	487,389	215,945
Balance at end of the year	₱1,372,477	₱1,145,324

In 2013, liabilities for purchased land with a nominal amount of ₱749.35 million were recorded at fair value at inception date amounting ₱737.59 million. These liabilities for purchased land are payable over a period of two (2) to four (4) years. The fair value is derived using discounted cash flow model using the discount rate ranging from 1.02% to 3.32% in 2013 based on applicable rates for similar types of liabilities.

	2013	2012
Balance at beginning of year	₱-	₱23,397
Accretion for the year (Note 27)	(9,174)	(23,397)
	(₱9,174)	₱-



Accretion amounting ₱9.17 million and ₱23.40 million are recorded as finance costs in 2013 and 2012, respectively (Note 27).

17. Accounts and Other Payables

This account consists of the following:

	2013	2012
Trade and other payables		
Suppliers and subcontractors (Note 20)	₱6,624,948	₱8,495,512
Others	574,878	511,776
Accrued costs and expenses	6,650,148	4,210,227
Output VAT payable	1,410,799	543,445
	15,260,773	13,760,960
Less noncurrent portion of trade and other payables (Note 20)	1,496,710	1,460,267
	₱13,764,063	₱12,300,693

Suppliers

Payable to suppliers include liabilities to various foreign and local suppliers for open account purchases of equipment and equipment parts and supplies. These are noninterest bearing and are normally settled on a 30-to 60-day credit terms.

Subcontractors

Subcontractors payable arise when the Group receives progress billing from its subcontractors for the construction cost of a certain project and is recouped against monthly billings. These subcontractors were selected by the contract owners to provide materials, labor and other services necessary for the completion of a project. These are non-interest bearing and are normally settled on 15-to-60 day terms.

Other Payables

Other payables include payable to nickel mine rights owner and marketing agents. These are noninterest-bearing and are normally settled within one (1) year.

Accrued Costs and Expenses

Accrued costs and expenses consist mainly of accrual of salaries, taxes and others. Further analysis is provided below:

	2013	2012
Accrued construction cost	₱4,775,876	₱2,578,564
Payable to Department of Energy (DOE) (Note 31)	877,948	1,007,849
Accruals:		
Accrued interest	202,092	95,024
Accrued salaries	77,408	156,845
Accrued professional fees	6,039	8,649
Withholding and others taxes	161,240	233,905
Shipping cost	89,536	-
Financial benefit payable	43,588	13,591

(Forward)



	2013	2012
Accrued rental	₱36,914	₱22,496
Dividends	4,459	12,102
Others	375,048	81,202
	₱6,650,148	₱4,210,227

Accrued construction cost

Accrued construction costs pertain to direct materials, labor, overhead and subcontractor costs for work accomplished by the suppliers and subcontractors but were not yet billed to DMCI. As of December 31, 2013 and 2012, accrued construction cost amounted to ₱4,775.88 million and ₱2,578.56 million, respectively.

Payable to DOE

Liability to the DOE and local government units represents the share of DOE and local government units in the gross revenue from SMC's coal production (including accrued interest on the outstanding balance) computed in accordance with the coal operating contract between SMC, DOE and the local government units dated July 11, 1977, as amended on January 16, 1981. The contract is for a maximum period of 35 years (inclusive of the developmental stage and renewals) up to July 2012.

Financial benefits payable

As mandated by the R.A. 9136 or the Electric Power Industry Reform Act (EPIRA) of 2001 and the Energy Regulations No. 1-94, issued by Department of Energy (DOE), the BOD authorized the Group on June 10, 2010 to enter and execute a Memorandum of Agreement with the DOE relative to or in connection with the establishment of Trust Accounts for the financial benefits to the host communities equal to ₱0.01 per kilowatt hour generated.

Others

Others include accruals for contracted services, utilities, supplies, advertising, commission and other administrative expenses.

18. Customers' Advances and Deposits

The customers' advances and deposits are due to the following:

	2013	2012
Real estate customers	₱4,619,704	₱3,315,565
Coal and nickel ore supply contracts	309,997	40,330
	₱4,929,701	₱3,355,895

Real Estate Customers

Customers' advances and deposits from real estate customers represent reservation fees and initial collections received from customers before the two parties enter into a sale transaction. These were payments from buyers which have not reached the minimum required percentage. When the level of required percentage for revenue recognition is reached by the buyer, sale is recognized and these deposits will be recognized as revenue and will be applied against the receivable balance.



Coal and Nickel Ore Supply Contracts

These deposits represent advances from customers of SMC and DMC. Coal deposits are applied against future coal deliveries which occur within one year from the dates the deposits were made while nickel ore will be applied to related receivables upon consummation of the sale transaction.

19. Long-term Debt

Long-term debt pertains to the following obligations:

	2013	2012
Bank loans	₱34,644,843	₱24,833,115
Less current portion of bank loans	3,386,257	6,642,262
Noncurrent portion	₱31,258,586	₱18,190,853



Details of the bank loans follow (amounts in millions):

Loan Type	Date of Availment	Outstanding Balances		Maturity	Interest Rate	Payment Terms	Covenants/Collaterals
		2013	2012				
Local bank loans							
<i>SMC</i>							
Loan 1	Various availments in 2010, 2011 and 2013	₱342	₱948	Various maturities in 2012, 2013 and 2015	Floating rate payable quarterly and in arrears, to be repriced every 90 days	Interest payable quarterly and in arrears, subject to quarterly setting and principal repayable in bullet at the end of three (3) years from drawdown date.	Proceeds of the loans were restricted for the purchase of mining equipment; Unsecured loan
Loan 2	July 2011	–	230	July 2013	Floating rate, to be repriced every 30 to 180 days	Interest shall be payable on the last day of the current interest period or the 90th day of said period whichever occurs earlier and full payment of principal at maturity.	Unsecured loans
Loan 3	Various availments in 2010, 2011 and 2013	2,743	2,557	Various maturities in 2012, 2013, 2014 and 2016	Floating rate to be repriced every 90 days	Interest payable in 90 days; not deducted from proceeds of loans and principal repayable in maturity.	Proceeds of the loan will be used to finance capital expenditures and general corporate purposes Financial Covenants: Current Ratio not less than 1:1 and Debt-Equity Ratio not to exceed 2:1; compliant
Loan 4	Various availments in 2011 and 2013	1,554	1,040	Various maturities in 2013, 2014, 2015 and 2016	Floating rate, aggregate of the margin (1.20%) and LIBOR, to be repriced every 90 to 180 days	Interest payable in arrears for the relevant interest period and principal repayable in semi-annual installments commencing on the 12 th month after the date of the Agreement until date of final maturity.	Proceeds of the loan were restricted for capital expenditure requirements and refinancing of existing debts Financial Covenants: Current Ratio not less than 1:1, Debt-Equity Ratio not exceeding 2:1, Debt-EBITDA Ratio not exceeding 3:1, compliant
Loan 5	October 2013	152	–	September 24, 2015	Floating rate	Interest and principal are payable on the date of maturity	Unsecured loans Current Ratio at least 1.0x; Debt-Equity Ratio at least 2.0x; compliant
Loan 6	January 2011	–	131	January 2013	Interest rate subject to review and resetting based on the prevailing market rate	Balloon payment of the principal at maturity	Unsecured loans

(Forward)



Loan Type	Date of Availment	Outstanding Balances		Maturity	Interest Rate	Payment Terms	Covenants/Collaterals
		2013	2012				
<i>SLPGC</i>							
Mortgage payable	February 4, 2012	₱5,675	₱547	February 4, 2022	PDST-F + Spread or BSP Overnight Rate, whichever is higher	The principal amount shall be paid in twenty-seven equal consecutive quarterly installments commencing on the fourteenth quarter from the initial borrowing date. Final repayment date is ten (10) years after initial borrowing.	67% of issued and outstanding shares of SLPGC owned by the Parent Company
<i>SCPC</i>							
Mortgage payable	May 20, 2010	5,342	6,857	May 20, 2017	PDST-F benchmark yield for 3-month treasury securities + 1.75%	Payable in twenty-five (25) equal consecutive quarterly installments commencing on May 20, 2011	Monies in the Collateral Accounts, supply receivables, proceeds of asset and business continuity insurance obtained by SCPC, project agreements, first-ranking mortgage on present and future real assets and first-ranking chattel mortgage
<i>Wire Rope</i>							
Loans payable	Various	2	–	October 22, 2015 and July 7, 2016	15.16% to 17.00%	Payable upon maturity of the loans.	None
<i>Beta Electric</i>							
Loans payable	Various	13	–	July 2015	8.68% to 10.89%	Payable in equal monthly installments starting May 2007 up to July 2015,	The loans are secured by a chattel mortgage for the whole amount of the Beta Electric's transportation equipment purchased using the proceeds of these loans.
<i>PDI</i>							
Fixed rate corporate notes	October 2012	14,791	5,865	Various maturities from 2016 to 2020	PDST-F Issue Date and ending three (3) months after such Issue Date, and every three (3) months thereafter	Payments shall be made in each tranche is equal to 1% every year from the issue date and the balance payable at maturity	Financial Covenants: Debt-Equity Ratio not exceeding 3.2 times, Current ratio is at least 1.75 times. The Group is in compliance with the above covenants as of December 31, 2013 and 2012.
<i>PDI</i>							
Agreement to purchase receivables (with recourse)	Various	4,031	6,658	Various	5%-8% p.a.	Payable in equal and continuous monthly payments not exceeding 120 days commencing one (1) month from date of execution.	Real estate receivables with carrying value of ₱1.06 billion and ₱1.70 billion in 2013 and 2012, respectively (Note 7).
		34,645	24,833				
Less: current portion		3,386	6,642				
Long-term debt net of current portion		₱31,259	₱18,191				



Local bank loans

SMC

As of December 31, 2013, there is no more available borrowing facility that can be drawn.

The maturities of long-term debt at nominal values as of December 31, 2013 and 2012 follow:

	2013	2012
Due in:		
2013	₱-	₱5,182,555
2014	2,146,129	2,625,603
2015	3,149,752	1,545,013
2016	5,111,266	1,611,596
2017	1,608,188	848,459
2018	841,652	81,238
2019	842,398	81,299
2020	843,144	81,359
2021	843,891	81,420
2022	422,226	40,732
	15,808,646	12,179,274
Less debt issuance cost	25,936	2,506
Net long-term debt	₱15,782,710	₱12,176,768

Mortgage payable

SLPGC

On February 4, 2012, SLPGC entered into an ₱11.50 billion Omnibus Agreement with Banco de Oro Unibank (BDO), Bank of the Philippine Island (BPI) and China Banking Corporation (CBC) as Lenders. As security for the timely payment of the loan and prompt observance of all the provision of the Omnibus Agreement, the 67% of issued and outstanding shares of SLPGC owned by Semirara were pledged on this loan. The proceeds of the loan will be used for the engineering, procurement and construction of 2x150 MW coal-fired thermal power plant.

Breakdown of the syndicated loan is as follows:

	Amount
BDO Unibank	₱6,000,000
BPI	3,000,000
CBC	2,500,000
	₱11,500,000

Details of the loan follow:

- a. Interest: At applicable interest rate (PDST-F + Spread or BSP Overnight Rate, whichever is higher). Such interest shall accrue from and including the first day of each interest period up to the last day of such interest period. The Facility Agent shall notify all the Lenders of any adjustment in an interest payment date at least three banking days prior to the adjusted interest payment date.
- b. Repayment: The principal amount shall be paid in twenty-seven equal consecutive quarterly installments commencing on the fourteenth quarter from the initial borrowing date. Final repayment date is ten (10) years after initial borrowing.



The first drawdown was made on May 24, 2012 amounting to ₱550.00 million. While in April and November of 2013, second and third drawdowns were made which amounted to ₱2.89 billion and ₱2.26 billion, respectively. As of December 31, 2013 and 2012, amortization of debt issuance cost recognized as part of “Property, plant and equipment” account in the consolidated statements of financial position amounted to ₱2.33 million and ₱0.24 million, respectively.

Rollforward of debt issuance cost follows:

	2013	2012
At January 1	₱2,506	₱-
Additions	25,757	2,750
Amortization	(2,327)	(244)
At December 31	₱25,936	₱2,506

Mortgage payable by SLPGC provide certain restrictions and requirements with respect to, among others, maintain and preserve its corporate existence, comply with all of its material obligations under the project agreements, maintain at each testing date a Debt-to-Equity ratio not exceeding two times, grant loans or make advances and disposal of major property. These restrictions and requirements were complied with by SLPGC as of December 31, 2013 and 2012.

Provision in the loan indicates that the borrower shall pay to the lenders, a commitment fee equivalent to one-half (1/2%) per annum of any portion of a scheduled drawdown amount that remains undrawn after the lapse of the relevant scheduled drawdown month. As of December 31, 2013 and 2012, SLPGC has paid commitment fee amounting to ₱6.99 million and ₱2.30 million, respectively and these were recognized under the “Finance costs” account in the consolidated statements of comprehensive income.

The amount of undrawn borrowing facilities that maybe available in the future amounts to ₱5.80 billion.

SCPC

On May 20, 2010, SCPC entered into a ₱9.60 billion Omnibus Loan Security Agreement (“Agreement”) with BDO, BPI and Philippine National Bank (PNB) as Lenders, SMC as Guarantor, BDO Capital and Investment Corporation as Lead Arranger and Sole

Bookrunner, BPI Capital Corporation and PNB Capital and Investment Corp. as Arrangers, and BDO Unibank, Inc., Trust and Investments Group as Security Trustee, Facility Agent and Paying Agent. The loan was fully drawn by SCPC on the same date.

Mortgage payable by SCPC was collateralized by all monies in the Collateral accounts, supply receivables, proceeds of any asset and business continuity insurance, project agreements and first-ranking mortgage on present and future real assets. Further, 67% of issued and outstanding shares in SCPC owned by SMC were also pledged on this loan.

Breakdown is as follows:

BDO Unibank	₱6,000,000
BPI	2,000,000
PNB	1,600,000
	₱9,600,000



The Agreement was entered into to finance the payments made to PSALM pursuant to the APA and LLA, and ongoing plant rehabilitation and capital expenditures.

Details of the loan follow:

- a. Interest: At a floating rate per annum equivalent to the three (3) months Philippine Dealing System Treasury-Fixing (PDST-F) benchmark yield for treasury securities as published on the PDEX page of Bloomberg (or such successor electronic service provider at approximately 11:30 a.m. (Manila Time) on the banking day immediately preceding the date of initial borrowing or start of each interest period, as applicable, plus a spread of 175 basis points.
- b. Repayment: The principal amount shall be payable in twenty-five equal consecutive quarterly installments commencing on the twelfth month from the initial borrowing date. Final repayment date is seven (7) years after initial borrowing.

Rollforward of the deferred issuance cost follows:

	2013	2012
At January 1	₱55,304	₱82,428
Amortization (Note 27)	(21,752)	(27,124)
At December 31	₱33,552	₱55,304

Amortization of debt issuance cost recognized under "Finance cost" account in the consolidated statements of comprehensive income amounted to ₱21.75 million, ₱27.12 million and ₱22.42 million for the years 2013, 2012 and 2011, respectively (see Note 27).

As of December 31, 2013, there is no more available borrowing facility that can be drawn.

Loans payable

Wire Rope

Loans payable represents unsecured loans from local banks bearing annual interest rates ranging from 17.00% to 18.14% and 15.16% to 17.00% in 2013 and 2012, respectively. Wire Rope availed additional loans amounting to ₱1.33 million and ₱0.90 million and made payments to the loans amounting to ₱0.85 million and ₱0.32 million, respectively.

Beta Electric

Long-term debt represents peso-denominated long-term borrowings from local banks which bear interest ranging from 8.68% to 10.89% and 8.68% to 10.78% per annum in 2013 and 2012, respectively, and are payable in equal monthly installments starting May 2007 up to July 2015. The loans are secured by a chattel mortgage for the whole amount of Beta Electric's transportation equipment purchased using the proceeds of these loans.

In 2013, Beta Electric obtained short-term loans from its local bank with an aggregate amount of ₱55.00 million which bear interest ranging from 5.50% to 5.75%. As of December 31, 2013, the outstanding balance from loans amounted to ₱13.00 million which is payable on January 2014.

Fixed rate corporate notes

PDI

In October 2012, PDI signed corporate notes facility agreement on the issuance of 7-year peso denominated notes in the aggregate amount of ₱10,000.00 million with local banks. Proceeds of the notes facility were used to fund land acquisition, general operations and project development and construction.



The notes were issued in three (3) tranches and payments were made in each tranche are as follows:

Quarter from Issue Date	Based on aggregate % of issue amount of each Series (Equally divided over the applicable quarters)
7 th to 10 th Quarter	2%
11 th to 14 th Quarter	4%
15 th to 18 th Quarter	5%
19 th to 27 th Quarter	12%
Final Maturity	77%
Total	100%

Tranche 1 of the ₱10,000.00 million Series C was issued on October 31, 2012 in the aggregate amount principal amount of ₱1,000.00 million. Tranche 2 (Series D) and 3 (Series E) were issued on April 10, 2013 and July 30, 2013 in the aggregate principal amount of ₱4,000.00 million and ₱5,000.00 million, respectively.

The note is issued in registered form in the minimum denominations of ₱100.00 million and multiples of ₱10.00 million each. Corporate notes shall bear interest three (3) months after date of issue and every three (3) months thereafter.

Tranche 1 (Series A) of ₱5,000.00 million corporate notes was issued on January 28, 2011, in the aggregate principal amount of ₱2,000.00 million while Tranche 2 (Series B) were issued on March 17, 2011, in the aggregate principal amount of ₱3,000.00 million. They were issued in registered form in the minimum denominations of ₱100.00 million and multiples of ₱10.00 million each.

Corporate notes shall bear interest from Tranche 1 and 2 PDST-F Issue Date and ending three (3) months after such Issue Date, and every three (3) months thereafter. The interest rate shall initially be the PDST-F benchmark yield for five-year treasury securities (Base Rate) on banking day immediately preceding an Issue Date plus the Margin (125 basis points) for each of the Tranche, gross of any applicable withholding taxes. Interest is payable quarterly.

Unamortized debt issuance costs included in fixed rate corporate notes as of 2013 and 2012 amounted to ₱109.50 million and ₱85.17 million, respectively.

The rollforward analysis of unamortized debt issuance cost follows:

	2013	2012
Balance at beginning of year	₱85,171	₱47,891
Availments	45,000	48,660
Amortization of debt issue cost	(20,676)	(11,380)
Balance at end of year	₱109,495	₱85,171

In 2013, interest expense incurred and capitalized interest related to long-term debt amounted to ₱1,172.71 million and ₱672.58 million, respectively. The average capitalization rates used are 6.44% and 6.88% of the average expenditures in 2013 and 2012, respectively.

The ₱10,000.00 million and ₱5,000.00 million corporate notes facility agreement requires PDI to ensure that debt-to-equity ratio will not exceed 3.2 times and 2.0 times, respectively, and current ratio is at least 1.75 times. As of December 31, 2013 and 2012, PDI is fully compliant with these requirements.



As of December 31, 2013 and 2012, corporate notes recognized are unsecured.

Agreement to purchase receivables

PDI entered into various purchase agreements with financial institutions whereby the subsidiaries assigned its receivables. The purchase agreements provide that the subsidiaries should substitute defaulted contracts to sell with other contracts to sell of equivalent value. The subsidiaries still retain the assigned receivables in the receivables account and record the proceeds from these sales as loans payable which amounted to ₱4,031.25 million and ₱6,658.00 million as of December 31, 2013 and 2012, respectively (Note 7). The agreements also provide the submission of condominium certificates of title and their related postdated checks issued by the buyers. These loans bear interest at prevailing market rates and are payable in various maturity dates. The average effective interest rate ranges from 5.25% to 5.75% and 5.00% to 6.50% in 2013 and 2012, respectively.

Working capital loan

The Group availed of various working capital loans including car financing and leasing.

Unused credit lines

The Group has unused credit lines with local banks amounting ₱5.80 billion and ₱3.67 billion as of December 31, 2013 and 2012, respectively.

20. Other Noncurrent Liabilities

The details of this account consist of:

	2013	2012
Noncurrent trade payables (Note 17)	₱1,496,710	₱1,460,267
Provision for decommissioning and site rehabilitation	196,504	62,448
Others	–	4,940
	₱1,693,214	₱1,527,655

The rollforward analysis of the provision for decommissioning and site rehabilitation account follows:

	2013	2012
At January 1	₱62,448	₱47,582
Addition	133,189	5,266
Accretion of interest (Note 27)	867	9,600
At December 31	₱196,504	₱62,448

Accounts payable trade

Noncurrent payables includes noninterest-bearing payable to suppliers and subcontractors and accrued expenses which are expected to be settled within 2 to 3 years from the reporting date and retention contract payment that is being withheld from the contractors as guaranty for any claims which are expected to be settled a year after the turn-over of projects.



Provision for decommissioning and site rehabilitation

Discount rates used by the Group to compute for the present value of liability for decommissioning and site rehabilitation cost are from 5.79% to 8.77% in 2012 and 3.63% to 4.63% in 2013.

Additions pertain to the effects of changes in estimates as to the extent and costs of rehabilitation activities, cost increases and changes in discount rates based on relative prevailing market rates.

21. Related Party Transactions

Related parties are considered to be related if one party has the ability, directly or indirectly, to control the other party or exercise significant influence over the other party in making the financial and operating decisions. Parties are also considered to be related if they are subject to common control or common significant influence. Related parties may be individuals or corporate entities.

Transactions entered into by the Group with related parties are at arm's length and have terms similar to the transactions entered into with third parties. In the regular course of business, the Group's significant transactions with related parties include the following:

	2013			
	Due from (Due to)	Amount / Volume*	Term	Conditions
Associates				
<i>Receivable from related parties</i>				
a. Sale of property, plant and equipment	₱107,016	₱107,016	1-30 days	Unsecured, no impairment
<i>Others</i>				
b. Advances to subcontractors, suppliers and contract owners	1,979	–	Noninterest - bearing	Unsecured, no impairment
b. Retention receivable	98,527	–	Noninterest - bearing	Unsecured, no impairment
b. Construction contracts	287,008	1,223,146	Noninterest - bearing	Unsecured, no impairment
b. Billings in excess of costs and estimated earnings on uncompleted contracts	(29,286)	–	Payable on demand, noninterest-bearing	Unsecured
Affiliates				
<i>Receivable from related parties</i>				
c. Rental income	19,208	7,380	1-30 days	Unsecured, no impairment
d. Mine exploration and hauling services	5,372	6,588	1-30 days	Unsecured, no impairment
<i>Payable to related parties</i>				
f. Supply of materials	(444)	5,659	Payable on demand, noninterest-bearing	Unsecured
d. Mine exploration and hauling services	(20,139)	554,092	Payable on demand, noninterest-bearing	Unsecured
c. Lease of office spaces	(6,303)	6,386	Payable on demand, noninterest-bearing	Unsecured
g. Other general and administrative expense	(623)	953	Payable on demand, noninterest-bearing	Unsecured
h. Aviation services	(1,540)	6,890	Payable on demand, noninterest-bearing	Unsecured
i. Purchases of office supplies and refreshments	(2,726)	5,659	Payable on demand, noninterest-bearing	Unsecured
j. Labor charges	(2,184)	–	Payable on demand, noninterest-bearing	Unsecured
e. Office and parking rental expenses	(33)	2,793	Payable on demand, noninterest-bearing	Unsecured



		2012			
		Due from (Due to)	Amount / Volume*	Term	Conditions
Associates					
<i>Others</i>					
b. Advances to subcontractors, suppliers and contract owners	₱12,870	₱-		1-30 days	Unsecured, no impairment
b. Retention receivables	104,900	-		1-30 days	Unsecured, no impairment
b. Construction contracts	170,020	653,300		1-30 days	Unsecured, no impairment
b. Billings in excess of costs and estimated earnings on uncompleted contracts	(57,600)	-		Payable on demand, noninterest-bearing	Unsecured
Affiliates					
<i>Receivable from related parties</i>					
c. Rental income	187,296	6,942		1-30 days	Unsecured, no impairment
<i>Payable to related parties</i>					
d. Mine exploration and hauling services	(55,893)	438,731		30 days; noninterest-bearing	Unsecured
f. Supply of materials	(3,532)	30,335		30 days; noninterest-bearing	Unsecured
e. Office and parking rental expenses	(1,790)	3,668		Payable on demand; noninterest-bearing	Unsecured

*Balances presented pertain to transactions between related parties during the year. Amounts are not reduced by subsequent collections/payments during the year.

- (a) In December 2013, DMC sold various property, plant and equipment on account to BNC, an associate of TMC, which will be used for its mining operations in Palawan.
- (b) In 2013 and 2012, DMCI is engaged in the construction of Tarlac - Pangasinan - La Union Toll Expressway (TPLEX) through PIDC an associate of the Group.

Related contract revenue recorded by DMCI on PIDC amounted to ₱1,223.15 million and ₱653.30 million in 2013 and 2012, respectively.

DMCI has outstanding receivables from PIDC amounting to ₱287.01 million and ₱170.02 million as of December 31, 2013 and 2012, respectively.

Retention receivable and advances to contract owners amounted to ₱98.53 million and ₱1.98 million as of December 31, 2013 and ₱104.90 million and ₱12.87 million as at December 31, 2012, respectively.

Unliquidated advances from contract owners amounted to ₱29.29 million and ₱57.60 million as at December 31, 2013 and 2012, respectively.

- (c) Receivable from DMC Urban Property Developers, Inc. (UPDI), an affiliate under common stockholder amounted to ₱19.21 million and ₱187.30 million as at December 31, 2013 and 2012, respectively.

In 2013, UPDI had transactions with SMC representing long-term lease on office space and other transactions rendered to SMC necessary for the coal operations.

- (d) DMC-Construction Equipment Resources, Inc. (DMC-CERI), an affiliate, under common stockholder, has transactions with SMC for services rendered relating to the SMC's coal operations. These services are for the confirmatory drilling for coal reserve evaluation of



identified potential areas, exploratory drilling of other minerals within Semirara Island, dewatering well drilling along cut-off wall of Panian mine and fresh water well drilling for industrial and domestic supply under an agreement.

DMC-CERI also provides to SMC marine vessels for use in the delivery of coal to its various customers. The coal freight billing is on a per metric ton basis plus demurrage charges when delay will be incurred in the loading and unloading of coal cargoes.

The outstanding receivable of DMC from DMC-CERI pertains to repairs and maintenance, fuel and materials and meal allowances of barge and tugboat crews incurred, which are initially paid by DMC in behalf of DMC-CERI. The outstanding receivable is included in "Receivable from related parties" under "Receivables" account in the consolidated statements of financial position.

- (e) Asia Industries Inc., an affiliate, under common stockholder, had transactions with the Group for the rental of office and parking spaces to which related expenses are included in "Operating expenses" in the consolidated statements of income. The outstanding balance to Asia Industries, Inc. is lodged under "Payable to related parties" in the consolidated statements of financial position.
- (f) M&S Company, Inc. (M&S), an affiliate under common control, provides various supplies and materials to DMC in cash on delivery basis. M&S also rents out various equipment used in DMC's operations. This is included in "Cost of sales and services" in the consolidated statements of income.
- (g) Dacon, a shareholder of the Parent Company, provided maintenance of the Group's accounting system, Navision, to which related expenses are included under "Others" of "Operating expenses" in the consolidated statements of income.
- (h) Royal Star Aviation Inc. transports SMC's visitors and employees from Manila to Semirara Island and vice versa and bills the related party for the utilization costs of the aircrafts. The related expenses are included in "Cost of sales and services" in the consolidated statements of income. The outstanding balance to Royal Star Aviation, Inc. is included in "Payable to related parties" in the consolidated statements of financial position.
- (i) Prominent Fruits, Inc. supplies various office supplies and refreshments to SMC. The outstanding balance to Prominent Fruits, Inc. is included under "Payable to related parties" in the consolidated statements of financial position.
- (j) Payable to Sirawai pertains to labor charges incurred by DMC, which are initially paid by Sirawai in behalf of DMC. The outstanding payable to Sirawai is recorded in "Payable to related parties" in the consolidated statements of financial position.

Terms and conditions of transactions with related parties

Outstanding balances as of December 31, 2013 and 2012, which are unsecured and interest free, are all due within one year. As of December 31, 2013 and 2012, the Parent Company has not made any provision for impairment loss relating to amounts owed by related parties. This assessment is undertaken each financial year through examining the financial position of the related party and the market in which the related party operates.



Compensation of Key Management Personnel

Key management personnel of the Group include all directors and senior management. The aggregate compensation and benefits of key management personnel of the Group follows:

	2013	2012	2011
Short-term employee benefits	₱77,157	₱98,216	₱153,980
Post-employment benefits (Note 23)	8,572	13,552	11,248
	₱85,729	₱111,768	₱165,228

There are no agreements between the Group and any of its directors and key officers providing for benefits upon termination of employment, except for such benefits to which they may be entitled under the Group's pension plan.

22. Equity

Capital Stock

As of December 31, 2013 and 2012, the Parent Company's capital stock consists of:

	2013	2012
Preferred stock - ₱1 par value cumulative and convertible		
Authorized - 100,000,000 shares		
Issued - 3,780 shares	₱4	₱4
Common stock - ₱1 par value		
Authorized - 5,900,000,000 shares		
Issued - 2,655,494,000 shares	2,655,494	2,655,494
	₱2,655,498	₱2,655,498

The preferred stock is redeemable, convertible, non-voting, non-participating and cumulative with par value of ₱1.00 per share. The preferred shareholders' right of converting the preferred shares to common shares expired in March 2002.

In 2011, the Parent Company retired 600 preferred shares. The difference between the redemption price amounting ₱0.60 million was charged against the additional paid-in capital account.

On December 18, 1995, the Parent Company launched its Initial Public Offering where a total of 1.13 billion common shares were offered at an offering price of ₱9.12 per share.

Additional paid in capital account as of December 31, 2013 and 2012 and January 1, 2012 amounted to ₱4.77 billion.



Below is the summary of the Parent Company's track record of registration of securities with the SEC as of December 31, 2013:

Year	Number of Shares Registered (in billions)	Number of holders of securities as of year end
December 31, 2011	2.66	714
Add/(Deduct) Movement	-	-
December 31, 2012	2.66	714
Add/(Deduct) Movement	-	(8)
December 31, 2013	2.66	706

Retained Earnings

In accordance with SEC Memorandum Circular No. 11 issued in December 2008, the Parent Company's retained earnings available for dividend declaration (after reconciling items) as of December 31, 2013 and 2012 amounted to ₱18.60 billion and ₱8.48 billion, respectively.

Under the tax code, publicly held corporations are allowed to accumulate retained earnings in excess of capital stock and are exempt from improperly accumulated earnings tax.

Dividend declaration

The Parent Company's BOD approved the declaration of cash dividends in favor of all its stockholders as follows:

	2013	2012	2011
April 11, 2013, ₱1.20 per share cash dividend to stockholders of record as of April 26, 2013, payable on or before May 10, 2013.	₱3,186,593	₱-	₱-
April 11, 2013, ₱1.00 per share special cash dividend to stockholders of record as of April 26, 2013, payable on or before May 10, 2013.	2,655,494	-	-
November 14, 2013, ₱1.20 per share special cash dividend to stockholders of record as of November 29, 2013, payable on or before December 13, 2013.	3,186,593	-	-
May 15, 2012, ₱1.20 per share cash dividend to stockholders of record as of June 11, 2012, payable on or before July 7, 2011.	-	3,186,593	-

(Forward)



	2013	2012	2011
May 31, 2011, ₱1.00 per share cash dividend to stockholders of record as of June 15, 2011 payable on or before May 11, 2012	₱-	₱-	₱2,655,494
	₱9,028,680	₱3,186,593	₱2,655,494

On various dates in 2013, 2012 and 2011, Semirara, Beta and Wire rope declared dividends amounting ₱4,283.70 million, ₱4,282.46 million and ₱3,607.40 million, respectively, of which dividends to non-controlling interest amounted to ₱1,870.65 million, ₱1,870.18 million and ₱1,575.71 million, respectively.

Appropriation of retained earnings

On December 29, 2011 the BOD authorized the Parent Company to appropriate ₱3,000.00 million of its retained earnings for capital expenditures and investments which are expected to be utilized from 2012 to 2014.

On December 28, 2012, the Parent Company's BOD has appropriated ₱1,600.00 million from its unrestricted retained earnings as of December 31, 2012. The appropriated amount will be utilized for the stock subscription in DMCI Mining which it can use to fund ongoing acquisition of shares of stocks in TMC. The acquisition was completed in 2013. As of December 31, 2013, DMCI Mining accumulated shares in TMC aggregated 98.09% of outstanding shares (Note 33).

On December 27, 2013, the Parent Company's BOD has approved the reversal of the appropriation made in 2012 amounting to ₱3,800.00 million pertaining to the stock subscription in DMCI Mining which was used to fund the acquisition of shares of stocks in TMC. The appropriation was reversed to unappropriated retained earnings. On the same date, the BOD of the Parent Company authorized the appropriation out of its retained earnings for capital expenditures and investments amounting to ₱1,300.00 million.

The unappropriated retained earnings include accumulated equity in undistributed net earnings of consolidated subsidiaries, associates and jointly controlled entities accounted for under equity method of ₱22,816.89 million and ₱20,530.81 million as of December 31, 2013 and 2012, respectively. These are not available for dividend declaration until declared by the subsidiaries, associates and the jointly controlled entities.

Capital Management

The primary objective of the Group's capital management strategy is to ensure that it maintains a strong credit rating and healthy capital ratios in order to support its business and maximize shareholder value.

The Group manages its capital structure and makes adjustments to it, in light of changes in economic conditions. To maintain or adjust the capital structure, the Group may adjust the dividend payment to shareholders or issue new shares. There were no changes made in the Group's capital management objectives, policies or processes. The Group considers total stockholders' equity as capital. Equity, which the Group considers as capital, pertains to the equity attributable to equity holders of the Group less unrealized gain or loss on AFS financial assets.

The Group is not subject to any externally imposed capital requirements.



23. Employee Benefits

Retirement Plans

The Group has a funded, noncontributory, defined benefit pension plan covering substantially all of its regular employees. Provisions for pension obligations are established for benefits payable in the form of retirement pensions. Benefits are dependent on years of service and the respective employee's final compensation. The Group updates the actuarial valuation every year by hiring the services of a third party professionally qualified actuary. The latest actuarial valuation reports of the retirement plans were made as of December 31, 2013.

The Retirement Plan Trustee, as appointed by the Group in the Trust Agreement executed between the Group and the duly appointed Retirement Plan Trustee, is responsible for the general administration of the Retirement Plan and the management of the Retirement Fund. The Retirement Plan Trustee may seek the advice of counsel and appoint an investment manager or managers to manage the Retirement Fund, an independent accountant to audit the Fund and an actuary to value the Retirement Fund.

Under the existing regulatory framework, Republic Act 7641, The Retirement Pay Law, requires a provision for retirement pay to qualified private sector employees in the absence of any retirement plan in the entity, provided however that the employee's retirement benefits under any collective bargaining and other agreements shall not be less than those provided under the law. The law does not require minimum funding of the plan.

The following table summarizes the components of net pension expense (included in "Salaries, wages and employee benefits" account) and pension income (included in "Other income - net" account) in the consolidated statements of income (see Notes 25 and 28):

Pension Expense

	2013	2012 (As restated)	2011 (As restated)
Current service cost	₱154,761	₱108,857	₱67,926
Effect of the asset limit - loss	23,181	18,522	976
Net interest income on benefit obligation and plan assets	(57,899)	(44,280)	1,900
Past service cost - curtailment	(15,997)	-	-
Total pension expense	₱104,046	₱83,099	₱70,802

Pension Income

	2013	2012 (As restated)	2011 (As restated)
Current service cost	₱1,893	₱1,673	₱28,588
Effect of the asset limit - loss	1,819	1,217	22,488
Net interest income on benefit obligation and plan assets	(4,141)	(2,998)	(52,808)
Total pension income	(₱429)	(₱108)	(₱1,732)



Movements in the fair value of plan assets of the Group follow:

	December 31, 2013	December 31, 2012 (As restated)	January 1, 2012 (As restated)
Balances at beginning of year	₱1,934,152	₱1,530,206	₱1,247,551
Interest income on plan assets	115,403	97,242	98,839
Remeasurement gains	102,771	308,872	108,410
Contributions	37,000	–	78,623
Benefits paid	(3,324)	(2,037)	(3,162)
Transfers from the plan	–	(131)	(55)
Balances at end of year	₱2,186,002	₱1,934,152	₱1,530,206

Changes in the present value of the defined benefit obligation follow:

	December 31, 2013	December 31, 2012 (As restated)	January 1, 2012 (As restated)
Balances at beginning of year	₱914,845	₱774,999	₱593,509
Interest expense on obligation	53,363	49,964	47,931
Current service cost	156,654	110,531	96,514
Past service cost - curtailment	(15,997)	–	–
Benefits paid - from plan assets	(3,324)	(2,037)	(3,162)
Benefits paid - direct payments	(6,858)	(1,929)	–
Remeasurement losses (gains) arising from:			
Financial assumptions	9,329	45,637	(19,287)
Demographic assumptions	(131,839)	–	(8,368)
Experience adjustments	110	(62,189)	67,917
Transfers from the plan	–	(131)	(55)
Balances at end of year	₱976,283	₱914,845	₱774,999

Below is the net pension asset for those entities within the Group with net pension asset position:

	December 31, 2013	December 31, 2012 (As restated)	January 1, 2012 (As restated)
Present value of funded defined benefit obligations	₱600,785	₱575,379	₱492,403
Fair value of plan assets	1,904,269	1,681,033	1,323,508
	(1,303,484)	(1,105,654)	(831,105)
Effect on asset ceiling	506,761	420,863	313,084
Net pension asset	(₱796,723)	(₱684,791)	(₱518,021)



Movements in the net pension asset follow:

	December 31, 2013	December 31, 2012 (As restated)	January 1, 2012 (As restated)
Net pension asset at beginning of year	(₱684,791)	(₱518,021)	(₱382,226)
Net pension income	16,016	26,730	26,306
Amounts recognized in other comprehensive income	(90,948)	(193,500)	(112,085)
Contributions	(37,000)	-	(50,016)
Net pension asset at end of year	(₱796,723)	(₱684,791)	(₱518,021)

Below is the net pension liability for those entities within the Group with net pension liability position:

	December 31, 2013	December 31, 2012 (As restated)	January 1, 2012 (As restated)
Present value of funded defined benefit obligations	₱375,498	₱339,467	₱282,596
Fair value of plan assets	281,733	253,118	206,697
Net pension liability	₱93,765	₱86,349	₱75,899

Movements in the net pension liability follow:

	December 31, 2013	December 31, 2012 (As restated)	January 1, 2012 (As restated)
Net pension liability at beginning of year	₱86,349	₱75,899	₱25,353
Net pension expense	87,600	56,261	42,764
Amounts recognized in other comprehensive income	(73,324)	(43,880)	36,390
Contributions	-	-	(28,608)
Benefits paid - direct payments	(6,860)	(1,931)	-
Net pension liability at end of year	₱93,765	₱86,349	₱75,899

The Group does not expect to contribute into the pension fund for the year ending 2014.



The major categories and corresponding fair values of plan assets by class of the Group's Plan as at the end of each reporting period are as follow:

	December 31, 2013	December 31, 2012 (As restated)	January 1, 2012 (As restated)
Cash and cash equivalents			
Cash in banks	₱6,686	₱7,204	₱48,590
Time deposits	59,868	552	3,408
	66,554	7,756	51,998
Investments in stocks			
Common shares	1,484,374	1,429,494	1,088,902
Preference shares	18,149	38,217	31,510
	1,502,523	1,467,711	1,120,412
Investment in government securities			
Fixed rate treasury notes (FXTNs)	460,737	371,928	267,826
Retail treasury bonds (RTBs)	19,835	14,183	7,574
	480,572	386,111	275,400
Investment in other securities and debt instruments			
AAA rated debt securities	103,507	14,908	21,604
Not rated debt securities	16,132	46,894	54,380
	119,639	61,802	75,984
Other receivables	17,048	11,010	6,897
Accrued trust fees and other payables	(334)	(238)	(485)
Fair value of plan assets	₱2,186,002	₱1,934,152	₱1,530,206

The investment in stocks is further categorized as follows:

	December 31, 2013	December 31, 2012 (As restated)	January 1, 2012 (As restated)
Common shares			
Quoted			
Holdings	₱1,457,305	₱1,403,762	₱1,074,381
Mining and oil	17,146	13,894	-
	1,474,451	1,417,656	1,074,381
Unquoted			
Service	9,923	11,838	14,521
	1,484,374	1,429,494	1,088,902
Preference shares			
Quoted			
Holdings	18,149	9,633	2,644
Industrial	-	28,584	28,866
	18,149	38,217	31,510
	₱1,502,523	₱1,467,711	₱1,120,412



Trust fee paid in 2013, 2012 and 2011 amounted to ₱1.15 million, ₱0.83 million and ₱1.44 million, respectively.

The composition of the fair value of the Fund includes:

- *Cash and cash equivalents* - include savings and time deposit with various banks and special deposit account with Bangko Sentral ng Pilipinas (BSP SDA).
- *Investment in stocks*- includes investment in common and preferred shares both traded and not traded in the Philippine Stock Exchange (PSE).
- *Investment in government securities* - include investment in Philippine Retail Treasury Bonds (RTBs) and Fixed Rate Treasury Notes (FXTNs).
- *Investments in other securities and debt instruments* - include investment in long-term debt notes and retail bonds.
- *Other receivables* - includes interest and dividends receivable generated from investments included in the plan.
- *Accrued trust fees and other payables* - pertain mainly to charges of trust or in the management of the plan.

In 2013 and 2012, the Group's investments in stocks include equity securities of related parties as follows:

	December 31		Total
	2013	2012	
Equity securities:			
Fair value	₱27,268	₱357,622	₱1,521,791
Unrealized gains or losses on equity securities	14,125	28,518	384,200

The fund holds investments in shares of stock of the Parent Company with fair market value of ₱1,468.67 million, ₱1,083.22 million and ₱1,414.97 million in 2013, 2012 and 2011, respectively.

The overall administration and management of the plan rest upon the Plan's BOT. The voting rights on the above securities rest to the BOT for funds directly held through the Group's officers and indirectly for those entered into through other trust agreements with the trustee bank authorized to administer the investment and reinvestments of the funds.

The cost of defined benefit pension plans and the present value of the pension obligation are determined using actuarial valuations. The actuarial valuation involves making various assumptions. The principal assumptions used in determining pension and post-employment medical benefit obligations for the defined benefit plans are shown below:

	2013	2012	2011
Discount rate	4.26% to 6.15%	4.69% to 6.15%	6.08% to 6.75%
Salary increase rate	3.00% to 10.00%	3.00% to 10.00%	3.00% to 10.00%



There are no unusual or significant risks to which the Plan exposes the Group. However, in the event a benefit claim arises under the Retirement Plan and the Retirement Fund is not sufficient to pay the benefit, the unfunded portion of the claim shall immediately be due and payable from the Group to the Retirement Fund.

There was no plan amendment, curtailment, or settlement recognized in the years ended December 31, 2013 and 2012.

Sensitivity analysis on the actuarial assumptions

Each sensitivity analysis on the significant actuarial assumptions was prepared by remeasuring the DBO at the reporting date after first adjusting one of the current assumptions according to the applicable sensitivity increment or decrement (based on changes in the relevant assumption that were reasonably possible at the valuation date) while all other assumptions remained unchanged. The sensitivities were expressed as the corresponding change in the DBO.

It should be noted that the changes assumed to be reasonably possible at the valuation date are open to subjectivity, and do not consider more complex scenarios in which changes other than those assumed may be deemed to be more reasonable.

	2013	
	Increase (decrease)	Plan
Discount rates	+100 basis points	(₱76,263)
	-100 basis points	92,720
Salary increases	+1.00%	82,998
	-1.00%	(70,641)

It should be noted that the changes assumed to be reasonably possible at the valuation date are open to subjectivity, and do not consider more complex scenarios in which changes other than those assumed may be deemed to be more reasonable.

Asset-liability matching strategies

Each year, an Asset-Liability Matching Strategy (ALM) is performed with the result being analyzed in terms of risk-and-return profiles. It is the policy of the Trustee that immediate and near-term retirement liabilities of the Group's Retirement Fund are adequately covered by its assets. As such, due considerations are given that portfolio maturities are matched in accordance with due benefit payments. The retirement fund's expected benefit payments are determined through the latest actuarial reports. The allocation of the Group's plan assets consists of 68.73% equity instruments, 21.98% debt instruments in government bonds, 3.04% in cash and cash equivalents and 6.24% to others such as receivables generated from interest and dividends.

Funding arrangements

The Group is not required to pre-fund the future defined benefits payable under the Retirement Plan before they become due. For this reason, the amount and timing of contributions to the Retirement Fund are at the Group's discretion. However, in the event a benefit claim arises and the Retirement Fund is insufficient to pay the claim, the shortfall will then be due and payable from the Group to the Retirement Fund.



Shown below is the maturity analysis of the undiscounted benefit payments:

	December 31, 2013
Less than 1 year	₱283,447
More than 1 year to 5 years	105,575
More than 5 years to 10 years	327,985
More than 10 years to 15 years	6,161
More than 15 years to 20 years	9,901
	₱733,069

24. Costs of Sales and Services

Details of cost of sales and services follow:

	2013	2012	2011
Cost of Sales			
Cost of real estate inventory	₱6,567,151	₱4,434,929	₱4,080,030
Materials and supplies	3,157,875	4,172,074	1,821,355
Fuel and lubricants	2,453,660	3,043,332	4,242,030
Depreciation and amortization (Notes 12, 13 and 14)	1,114,655	1,448,149	1,797,211
Outside services (Note 21)	740,963	967,163	1,410,563
Hauling, shiploading and handling costs (Note 21)	540,763	763,505	1,198,572
Direct labor	521,267	456,399	622,215
Production overhead	387,108	600,582	456,211
Others	12,698	130,778	75,534
	15,496,140	16,016,911	15,703,721
Cost of Services			
Materials and supplies	8,850,595	5,981,336	6,515,312
Outside services (Note 21)	4,359,274	6,498,218	2,751,187
Direct labor	1,582,222	1,327,040	1,638,495
Depreciation and amortization (Notes 12, 13 and 14)	1,515,350	1,554,596	1,097,976
Fuel and lubricants	1,050,377	2,110,596	997,184
Production overhead	988,879	649,682	1,171,005
Spot purchases	229,197	130,367	1,500,978
Hauling, shiploading and handling costs (Note 21)	-	214,913	6,955
Others	152,934	96,977	46,167
	18,728,828	18,563,725	15,725,259
	₱34,224,968	₱34,580,636	₱31,428,980



Depreciation, depletion and amortization included in the consolidated statement of income follow:

	2013	2012	2011
Included in:			
Mining	₱1,114,655	₱1,448,149	₱1,797,211
Energy sales	1,015,839	1,345,551	776,589
Construction contracts	499,511	209,045	321,387
Operating expenses (Note 25)	1,556,057	327,097	198,656
	₱4,186,062	₱3,329,842	₱3,093,843
Depreciation, depletion and amortization of:			
Property, plant and equipment (Note 13)	₱4,566,006	₱3,743,700	₱3,496,747
Other noncurrent assets (Note 14)	36,726	28,123	18,009
Investment properties (Note 12)	6,826	4,908	6,313
	₱4,609,558	₱3,776,731	₱3,521,069

Depreciation, depletion and amortization capitalized in ending inventories amounted to ₱423.50 million, ₱446.89 million and ₱427.23 million in 2013, 2012 and 2011, respectively.

Salaries, wages and employee benefits included in the consolidated statements of comprehensive income follow:

	2013	2012	2011
Presented under:			
Costs of construction contracts	₱1,256,569	₱1,129,094	₱1,136,608
Operating expenses (Note 25)	1,112,195	1,063,108	1,007,532
Costs of mining	502,289	450,999	608,734
	₱2,871,053	₱2,643,201	₱2,752,874

25. Operating Expenses

This account consists of:

	2013	2012	2011
Government share (Note 31)	₱1,304,961	₱1,557,950	₱1,497,356
Depreciation and amortization (Notes 3, 12, 13, 14 and 24)	1,556,057	327,097	198,656
Salaries, wages and employee benefits (Notes 23 and 24)	1,112,195	1,063,108	1,007,532
Outside services	837,816	792,487	211,478
Repairs and maintenance	739,224	238,995	94,728
Commission	737,447	386,810	503,946
Taxes and licenses	638,735	530,723	677,460

(Forward)



	2013	2012	2011
Provision for doubtful accounts (Note 7)	₱443,650	₱78,297	₱15,178
Advertising and marketing	309,730	366,357	337,092
Rent (Note 37)	115,773	28,619	104,834
Communication, light and water	114,410	80,440	75,686
Entertainment, amusement and recreation	73,560	69,697	62,395
Insurance	66,347	61,687	68,172
Transportation and travel	62,285	54,507	47,292
Supplies	55,748	108,757	46,954
Association dues	39,834	40,081	50,276
Probable losses on:			
Other noncurrent assets (Note 14)	-	47,151	-
Miscellaneous	383,560	114,542	240,574
	₱8,591,332	₱5,947,305	₱5,239,609

26. Finance Income

Finance income is derived from the following sources:

	2013	2012	2011
Interest on:			
Real estate installment receivables	₱321,457	₱475,792	₱666,258
Short-term placements (Notes 4 and 10)	205,840	277,342	328,309
Bank savings account (Note 4)	119,307	77,677	88,597
Investment from sinking fund (Note 14)	12,173	17,210	7,210
Accretion on unamortized discount on real estate receivables (Note 7)	-	1,444	7,160
Accretion on unamortized discount on security deposits (Note 10)	-	-	169
	₱658,777	₱849,465	₱1,097,703



27. Finance Costs

The finance costs are incurred from the following:

	2013	2012	2011
Long-term borrowings	₱770,573	₱1,075,984	₱1,103,810
Bank loans and short-term borrowings	126,962	50,799	87,091
Accretion on unamortized discount on liabilities on purchased land and provision for decommissioning and site rehabilitation (Notes 16 and 20)	10,041	32,997	40,381
Amortization of debt issuance cost (Note 19)	21,752	38,748	30,603
	₱929,328	₱1,198,528	₱1,261,885

28. Other Income - Net

This account consists of:

	2013	2012	2011
Forfeitures and cancellation of real estate contracts	₱419,379	₱157,579	₱160,145
Sales of Fly Ash	203,180	130,236	6,871
Despatch income	170,349	-	-
Gain on sale of property, plant and equipment - net (Note 13)	144,855	127,497	57,565
Reversal of allowance for doubtful accounts (Note 7)	138,310	9,552	7,892
Rental income (Note 12)	84,453	274,170	53,807
Gain on reversal of impairment (Notes 6 and 14)	61,549	-	6,670
Gain on bargain purchase (Note 33)	31,041	-	-
Guarantee fee income	19,150	-	-
Management fee (Note 21)	10,890	3,131	55,308
Recoveries from insurance claims	10,632	41,546	35,180
Dividend income (Note 5)	4,291	5,679	4,547
Pension income (Note 23)	430	54,481	37,707
Loss on writedown of property, plant and equipment (Note 13)	(443,349)	(341,146)	-
Foreign exchange gain (loss) - net	(356,121)	332,447	(46,567)
Others	18,927	(8,789)	53,748
	₱517,966	₱786,383	₱432,873

Despatch income

Despatch income pertains to shiploading services rendered by the DMC to its customers.

Despatch income is earned upon completion of loading of nickel ore to the vessel. Income earned from shiploading services are based on the difference between the allowed and actual laytime of



nickel ore to the respective vessels nominated by its customers multiplied by the prevailing daily international market rates. These rates are provided by the ship owners prior to the loading of nickel ore and determined when the vessel is nominated and accepted. The rates to be used shall be included in the customer's vessel nomination and shall be confirmed by the DMC through its marketing agent.

Loss on writedown of property, plant and equipment

The Group incurred a loss from property, plant and equipment writedown due to the replacement of generation units and retirement of mining equipment amounting to ₱443.35 million and ₱341.15 million in 2013 and 2012, respectively (Note 13).

Others

Others include income arising from penalty charges for delayed payments of contracts receivable-housing, holding fees, fee for change of ownership, transfer fees, restructuring fees, lease facilitation fees, income derived from selling excess electricity produced by SMC to neighboring communities and others.

29. Income Tax

The provision for income tax shown in the consolidated statements of comprehensive income consists of:

	2013	2012 (As restated)	2011 (As restated)
Final	₱57,807	₱59,303	₱78,761
Current	1,835,525	1,601,010	763,135
Deferred	211,318	(185,759)	501,655
	₱2,104,650	₱1,474,554	₱1,343,551

The components of net deferred tax assets as of December 31, 2013 and 2012 follow:

	2013	2012 (As restated)
Deferred tax assets on:		
Allowance for:		
Doubtful accounts	₱10,668	₱3,969
Inventory obsolescence	17,413	1,727
Probable losses	11,048	1,678
Pension liabilities	14,867	14,827
Unrealized foreign exchange loss	142,051	27
Provision for decommissioning and site rehabilitation	1,519	-
NOLCO	33	666
MCIT	-	83
	197,599	22,977
Deferred tax liabilities on:		
Others - net unrealized gain	-	241
	-	241
	₱197,599	₱23,218



The components of net deferred tax liabilities as of December 31, 2013 and 2012 follow:

	2013	2012 (As restated)
Deferred tax assets on:		
Pension liabilities	P10,332	P-
Allowance for:		
Doubtful accounts	21,421	21,421
Probable losses	7,648	7,648
Unamortized discount on payable to landowners	2,710	6,239
Unamortized discount on receivables	-	414
	42,111	35,722
Deferred tax liabilities on:		
Excess of book over tax income pertaining to construction contracts and real estate sales	(922,333)	(727,933)
Capitalized interest on real estate for sale and development deducted in advance	(220,815)	(137,384)
Unamortized transaction cost on loans payable	(32,770)	(25,551)
Pension liabilities	(12,292)	(7,246)
Unrealized marked to market gain	(945)	(378)
Others - net unrealized gain	(2,340)	-
	(1,191,495)	(898,492)
	(P1,149,384)	(P862,770)

The Group has the following deductible temporary differences, NOLCO and MCIT that are available for offset against future taxable income or tax payable for which deferred tax assets have not been recognized:

	2013	2012 (As restated)
Allowance for doubtful accounts	P467,431	P121,698
NOLCO	74,024	10,863
Pension liabilities	23,780	92,606
Allowance for impairment losses	1,970	145,793
MCIT	1,139	525
Unrealized forex losses	177	51,468
Unrealized forex gains	(991)	-
Provision for decommissioning and site rehabilitation	-	51,738
Organizational costs	-	20
	P567,530	P474,711

The deferred income tax effects of the above deductible temporary differences for which no deferred tax assets are recognized amounted to P171.06 million and P142.78 million as of December 31, 2013 and December 31, 2012, respectively. Deferred tax assets are recognized only to the extent that taxable income will be available against which the deferred tax assets can be used.



The reconciliation of the statutory income tax rate to the effective income tax rate follows:

	2013	2012 (As restated)	2011 (As restated)
Statutory income tax rate	30.00%	30.00%	30.00%
Adjustments for:			
Tax-exempt income	(11.27)	(11.21)	(12.60)
Gain on sale of investment subjected to final tax at a lower rate - net	(8.00)	-	-
Nontaxable equity in net earnings of associates and jointly controlled entities	(7.40)	(16.59)	(16.08)
Nondeductible expenses	5.08	8.65	8.77
Interest income subjected to final tax at a lower rate - net	(0.17)	(0.21)	(0.34)
Nondeductible interest expense	0.04	0.11	0.12
Changes in unrecognized deferred tax assets	0.38	(0.14)	0.03
Non -taxable dividend income	(0.02)	(0.05)	(0.01)
Effective income tax rate	8.64%	10.56%	9.89%

Board of Investments (BOI) Incentives

PDI - New Developer of Mass Housing Project

On various dates in 2013 and 2012, several projects of the Company are registered on a non-pioneer status by the BOI as these projects fall under the infrastructure (Mass Housing Projects) listing of the Investment Priorities Plan.

Under the terms of its registrations with BOI, the Company is entitled, among others, to the following incentives:

- a. Income tax holiday (ITH) for a period of three (3) to four (4) years;
- b. Employment of foreign officials may be allowed in supervisory, technical or advisory positions for five (5) years from date of registration; and
- c. Importation of consigned equipment for a period of ten (10) years from date of registration, subject to the posting of re-export bond.

SMC - Expanding Producer of Coal

On September 26, 2008, BOI issued in favor of SMC a Certificate of Registration as an Expanding Producer of Coal in accordance with the provisions of the Omnibus Investments Code of 1987. Pursuant thereto, SMC shall be entitled to the following incentives, among others:

- a. ITH for six (6) years from September 2008 or actual start of commercial operations, whichever is earlier, but in no case earlier than the date of registration. For purposes of availment of ITH, a base figure of 2,710,091 metric tons (MT) representing SMC's average sales volume for the past three (3) years prior to the expansion shall be used.

SMC shall initially be granted a four (4) year - ITH. The additional two (2) year ITH shall be granted upon submission of completed or on-going projects in compliance with its Corporate Social Responsibility (CSR), which shall be submitted before the lapse of its initial four (4) year - ITH. SMC's ITH of 6 years is expected to lapse in September 2014. SMC has a pending application with BOI for another extension, the period of which is still to be determined.



- b. Employment of foreign nationals. This may be allowed in supervisory, technical or advisory positions for five (5) years from the date of registration. The president, general manager and treasurer of foreign-owned registered companies or their equivalent shall not be subject to the foregoing limitations.

Date of filing: Application shall be filed with the BOI Incentives Department before assumption to duty of newly hired foreign nationals and at least one (1) month before expiration of existing employment for renewal of visa.

- c. Simplification of Customs procedures for the importation of equipment, spare parts, raw materials and supplies.

On August 19, 2009, BOI granted SMC's request for a reduced base figure from 2,710,091 MT to 1,900,000 MT representing the average sales volume for the past eight (8) years (2000 to 2007) prior to registration with BOI.

SMC availed of tax incentive in the form of ITH on its income under registered activities amounting to ₱1.48 billion, ₱1.47 billion and ₱1.35 billion in 2013, 2012 and 2011, respectively.

SCPC - New Operator of the 600-MW Calaca Coal-Fired Power Plant

On April 19, 2010, SCPC was registered with the BOI as New Operator of the 600-MW Calaca Coal-Fired Power Plant on a Non-Pioneer Status in accordance with the provisions of the Omnibus Investments Code of 1987. Pursuant thereto, SCPC shall be entitled to the following incentives, among others:

- a. SCPC shall enjoy income tax holiday for four (4) years from April 2011 or actual start of commercial operations, whichever is earlier, but in no case earlier than the date of registration. Other incentives with no specific number of years of entitlement maybe enjoyed for a maximum period of ten (10) years from the start of commercial operation and/or date of registration. The ITH incentives shall be limited to the revenue generated from the sales of electricity of the 600 MW Batangas Coal-Fired Power Plant.
- b. For the first five (5) years from the date of registration, SCPC shall be allowed an additional deduction from taxable income of 50% of the wages corresponding to the increment in the number of direct labor for skilled and unskilled workers in the year of availment as against the previous year if the project meets the prescribed ratio of capital equipment to the number of workers set by the BOI of \$10,000 to one worker and provided that this incentive shall not be availed of simultaneously with the ITH.
- c. Employment of foreign nationals. This may be allowed in supervisory, technical or advisory positions for five (5) years from the date of registration. The president, general manager and treasurer of foreign-owned registered companies or their equivalent shall not be subject to the foregoing limitations.
- d. Importation of consigned equipment for a period of ten (10) years from the date of registration, subject to the posting of re-export bond.

On January 7, 2011, BOI approved SCPC's request for an earlier application of the ITH to be effective January 1, 2010.

On December 17, 2013, BOI approved SCPC's request for the extension for one (1) year of the ITH for the period January 1 to December 31, 2014.



SCPC availed of tax incentive in the form of ITH on its income under registered activities amounting to ₱5.02 billion and ₱2.53 billion in 2013 and 2012, respectively.

SLPGC - New Operator of 300-MW Batangas Coal Fired Power Plant

On June 21, 2012, the application for registration of SLPGC as new operator of 300 MW (Phase 1) Batangas Coal Fired Power Plant on a Non-Pioneer Status under the Omnibus Investments Code of 1987 (Executive Order No. 226) was approved. Pursuant thereto, SLPGC shall be entitled to the following incentives, among others:

- a. ITH for four (4) years from January 2015 or actual start of commercial operations, whichever is earlier but in no case earlier than the date of registration;
- b. For the first five (5) years from date of registration, the enterprise shall be allowed an additional deduction from taxable income of fifty percent (50%) of the wages corresponding to the increment in number of direct labor for skilled and unskilled workers in the year of availments as against the previous year if the project meets the prescribed ratio of capital equipment to the number of workers set by the Board and provided that this incentive shall not be availed of simultaneously with the ITH;
- c. Importation of consigned equipment for a period of ten (10) years from date of registration, subject to posting of re-export bond;
- d. Employment of foreign nationals. This may be allowed in supervisory, technical or advisory positions for five (5) years from date of registration; and
- e. Simplification of customs procedures for the importation of equipment, spare parts, raw materials and supplies.

DMCI Masbate - New Operator of a 24.4 MW Diesel Power Plant in Mobo, Masbate

On September 23, 2010, the BOI approved the registration of DMCI Masbate as New Operator of a 24.4 MW Diesel Power Plant in Mobo, Masbate on a Pioneer status under the Omnibus Investment Code of 1987. As a registered entity, DMCI Masbate is entitled to certain fiscal and non-fiscal incentives which include, among others, an income tax holiday (ITH) on the registered operations of the entity. Other incentives with no specific number of years of entitlement may be enjoyed for a maximum of ten (10) years from the start of commercial operation/date of registration.

DMCI Masbate availed of tax incentive in the form of ITH on its income under registered activities amounting to ₱65.46 million and ₱36.10 million in 2013 and 2012, respectively.



30. Earnings Per Share

The following table presents information necessary to calculate basic earnings per share on net income attributable to equity holders of the Parent Company (in thousands except basic earnings per share):

Basic/diluted earnings per share

	2013	2012 (As restated)	2011 (As restated)
Net income attributable to equity holders of Parent Company	₱18,937,380	₱9,735,834	₱9,562,954
Divided by weighted average number of common shares	2,655,494	2,655,494	2,655,494
Basic earnings per share	₱7.13	₱3.67	₱3.60

There were no dilutive potential ordinary shares. Accordingly, no diluted earnings per share is presented in 2013, 2012 and 2011.

31. Coal Operating Contract with DOE

On July 11, 1977, the Government, through its former Energy Development Board, awarded a 35-year COC to a consortium led by Vulcan Industrial & Mineral Exploration Corporation and Sulu Sea Oil Development Corporation that subsequently assigned said COC to SMC on April 7, 1980. On July 27, 1977, Presidential Decree (PD) 972 was amended by PD 1174: (a) increasing coal operators' maximum cost recovery from an amount not exceeding 70% to 90% of the gross proceeds from production, and (b) increasing the amount of a special allowance for Philippine corporations from an amount not exceeding 20% to 30% of the balance of the gross income, after deducting all operating expenses. As a result, SMC's COC was subsequently amended on January 16, 1981 reflecting said changes.

On June 8, 1983, the Ministry of Energy (now DOE), issued a new COC to SMC, incorporating the foregoing assignment and amendments. The COC gives SMC the exclusive right to conduct exploration, development and coal mining operations on Semirara Island until July 13, 2012. On May 13, 2008, the DOE granted SMC's request for an extension of its COC for another 15-year or until July 14, 2027.

On November 12, 2009, the COC was amended further, expanding its contract area to include portions of Caluya and Sibay islands, Antique, covering an additional area of 5,500 hectares and 300 hectares, respectively.

On April 29, 2013, the DOE issued a new COC to SMC, which grants it the exclusive right to conduct exploration, development and coal mining operations in the municipality of Bulalacao, province of Oriental Mindoro, up to a maximum of 36 years from its effective date. The COC covers two coal-bearing parcels of land covering areas of 2,000 and 5,000 hectares, respectively.

On June 7, 2013, the DOE issued a new COC to SMC, which grants it the exclusive right to conduct exploration, development and coal mining operations in the municipalities of Maitum and Kiamba, province of Sarangani, up to a maximum of 36 years from its effective date. The COC covers a coal-bearing parcel of land covering area of 5,000 hectares.



In return for the mining rights granted to SMC, the Government is entitled to receive annual royalty payments consisting of the balance of the gross income after deducting operating expenses, operator's fee and special allowance. SMC's provision for DOE's share under this contract and to the different LGU in the province of Antique, under the provisions of the Local Government Code of 1991, amounted to ₱1.30 billion, ₱1.56 billion and ₱1.50 billion in 2013, 2012 and 2011, respectively, included under "Operating expenses" in the consolidated statements of income (see Note 25). The liabilities, amounting to ₱0.88 billion and ₱1.01 billion as of December 31, 2013 and 2012 are included under the "Accounts and other payables" account in the consolidated statements of financial position (see Note 17).

The DOE, through the Energy Resources Development Bureau, approved the exclusion of coal produced and used solely by SMC to feed its power plant in determining the amount due to DOE.

32. Material Partly-Owned Subsidiary

The financial information of the Group's subsidiary with material non-controlling interest (NCI) is provided below. This information is based on amounts before intercompany eliminations.

Semirara Mining Corporation and Subsidiaries

	2013	2012
Statement of financial position		
Current assets	₱14,800,206	₱11,711,754
Noncurrent assets	29,927,185	24,483,577
Total assets	44,727,391	36,195,331
Current liabilities	9,990,894	12,171,753
Noncurrent liabilities	14,608,985	7,153,247
Total liabilities	24,599,879	19,325,000
Equity	₱20,127,512	₱16,870,331
Statement of comprehensive income		
Revenue	₱27,331,160	₱24,150,248
Cost of sales	14,110,496	14,643,941
Gross profit	13,220,664	9,506,307
Operating expenses	(5,264,518)	(3,398,375)
Other income (expenses)	(554,393)	290,312
Income before income tax	7,401,753	6,398,244
Provision for (benefit from) income tax	(117,838)	39,604
Net income	7,519,591	6,358,640
Other comprehensive income	12,589	(16,393)
Total comprehensive income	₱7,532,180	₱6,342,247
Cash flow information		
Operating	₱12,654,664	₱6,934,202
Investing	(8,877,860)	(6,235,677)
Financing	498,470	(5,106,300)
Effect of exchange rate changes on cash and cash equivalents	9,643	(63,074)
Net increase (decrease) in cash and cash equivalents	₱4,284,917	(₱4,470,849)



The accumulated balances of material noncontrolling interest as at December 31, 2013 and 2012 amounted to ₱7,363.54 million and ₱8,790.17 million, respectively. Dividends paid to noncontrolling interests amounted to ₱1,867.32 million and ₱1,867.23 million, respectively.

33. Business Combination

On October 23, 2012, DMCI Mining Corporation (DMC), a wholly owned subsidiary of the Group, purchased from Daintree Resources Limited 8,480,250 common shares or 17.01% ownership in TMC for GBP 3.4 million or ₱226.90 million. TMC is an investment holding company incorporated in England and Wales on May 29, 2007 and is engaged in ore and mineral mining and exploration. TMC has strategic interests in privately owned nickel companies in the Philippines, Berong Nickel Corporation, Ipilán Nickel Corporation and Ulugan Nickel Corporation.

In 2013, DMC increased its interest in TMC by acquiring additional shares through a mandatory cash offer to TMC's shareholders. As of December 31, 2013, DMC holds 49,148,335 shares and voting rights representing 98.06% of voting rights. The acquisition of majority interest in TMC strengthens the Group's strategic objective to be a nickel mining corporation.

On December 20, 2013, DMC acquired majority seats in the Board of TMC.

As at December 31, 2013, the Group assessed that its investment in TMC be accounted for as investment in subsidiary in accordance with the guidance set out by PFRS 10. The assets, liabilities and equity of TMC have been consolidated in the financial statements of the Group on December 20, 2013, the date when control is obtained.

In its 2013 financial statements, the initial accounting for business combination was not yet completed because the valuation of TMC's mining rights was not yet finalized.

The following table summarizes the amounts of the provisional assets acquired and liabilities assumed recognized at the acquisition date (in thousand British Pounds):

	Fair value recognized on acquisition date
Assets	
Cash and cash equivalents	£391
Trade and other receivables	67
Other current assets	25
Furniture and equipment	6
Noncurrent receivables	13,711
Investment in associates	10,676
Other noncurrent assets	41
	24,917
Liabilities	
Trade and other payables	561
Accrued expenses	241
	802
Fair value of net assets acquired	£24,115



The Group assessed that the carrying values of the assets acquired and liabilities assumed approximates fair values for the purpose of provisional accounting.

Excess of provisional fair values of net identifiable assets over the consideration paid on the business combination of TMC follows in thousands:

Fair value of net assets acquired	£24,115
Less amount of consideration paid for the acquisition	23,688
Excess of fair value of identifiable net assets over the consideration, in London Pound	£427
Excess of fair value of identifiable net assets over the consideration, as converted to Philippine Peso	₱31,041

Excess of fair value of net identifiable assets over the consideration paid is recorded under “Other income” account in the consolidated statements of income.

TMC has no contributed profits or loss from the date of acquisition to December 31, 2013. If the acquisition had taken place at the beginning of the year, net income before tax would have decreased by ₱263.61 million because of the losses incurred by TMC.

34. Cumulative Translation Adjustment

Cumulative translation adjustment represents exchange differences arising from the translation of financial statements of the foreign subsidiary, TMC, whose functional currency is the British Pounds.

35. Operating Segments

Business Segment Information

For management purposes, the Group is organized into six (6) major business units that are largely organized and managed separately according to industry.

Construction - engaged in various construction component businesses such as production and trading of concrete products, handling steel fabrication and electrical and foundation works.

Coal mining - engaged in the exploration, mining and development of coal resources on Semirara Island in Caluya, Antique.

Nickel mining - engaged primarily in mining and selling nickel ore from existing stockpile in Benguet and Acoje mines in Zambales.

Real estate - focused in mid-income residential development carried under the brand name DMCI Homes.

Power - engaged in the business of a generation company which designs, constructs, invest in, and operate power plants.



Water - includes share in net earnings from associates, DMWC and Subic Water, which are engaged in water services for the west portion of Metro Manila and Olongapo City and Subic Bay Freeport, respectively.

No operating segments have been aggregated to form the above reportable operating segments. Management monitors the operating results of its business units separately for the purpose of making decisions about resource allocation and performance assessment. Segment performance is evaluated based on revenue, earnings before interest, income taxes and depreciation and amortization (EBITDA) and operating profit or loss, and is measured consistently in the consolidated financial statements.

The Group has no significant customer which contributes 10.00% or more to the revenues of the Group.

Group financing (including finance costs and finance income) and income taxes are also managed per operating segments. Transfer prices between operating segments are on an arm's length basis in a manner similar to transactions with third parties.

Business Segments

The following tables present revenue, net income (loss) and depreciation, depletion and amortization information regarding business segments for the years ended December 31, 2013, 2012 and 2011 and property, plant and equipment additions, total assets and total liabilities for the business segments as of December 31, 2013, 2012 and 2011:



Year ended December 31, 2013 (Amounts in Thousands)

	Construction and Others*	Coal Mining	Nickel Mining	Real Estate Development	Power	Water	Parent Company	Total
Revenue	₱14,359,502	₱12,573,569	₱264,897	₱12,165,988	₱16,606,674	₱-	₱-	₱55,970,630
Other income (expense) – net	1,877	(385,609)	416,216	606,300	(244,585)	1,914,601	9,168,830	11,477,630
	14,361,379	12,187,960	681,113	12,772,288	16,362,089	1,914,601	9,168,830	67,448,260
Cost of sales and services (before depreciation and amortization)	11,597,315	7,550,216	338,924	6,670,706	5,437,802	-	-	31,594,963
General and administrative expense (before depreciation and amortization)	450,590	1,672,319	93,190	2,237,856	2,473,961	-	107,359	7,035,275
	12,047,905	9,222,535	432,114	8,908,562	7,911,763	-	107,359	38,630,238
EBITDA	2,313,474	2,965,425	248,999	3,863,726	8,450,326	1,914,601	9,061,471	28,818,022
Other income (expenses)								
Finance income (cost) (Notes 26 and 27)	35,109	(150,739)	1,288	(145,369)	(219,481)	-	208,641	(270,551)
Depreciation and amortization (Notes 24 and 25)	(577,946)	(1,142,675)	(81,118)	(160,590)	(2,221,526)	-	(2,207)	(4,186,062)
Pretax income	1,770,637	1,672,011	169,169	3,557,767	6,009,319	1,914,601	9,267,905	24,361,409
Provision (benefit) for income tax (Note 29)	461,018	(131,452)	-	902,833	28,307	-	843,944	2,104,650
Net income	₱1,309,619	₱1,803,463	₱169,169	₱2,654,934	₱5,981,012	₱1,914,601	₱8,423,961	₱22,256,759
Net income attributable to non-controlling interest	₱34,822	₱781,215	₱-	₱-	₱2,503,342	₱-	₱-	₱3,319,379
Net income attributable to equity holders	₱1,274,797	₱1,022,248	₱169,169	₱2,654,934	₱3,477,670	₱1,914,601	₱8,423,961	₱18,937,380
Segment Assets								
Cash	₱3,315,307	₱1,709,481	₱352,028	₱6,727,312	₱3,179,089	₱-	₱9,491,278	₱24,774,495
Receivables	3,811,385	1,929,919	1,165,819	10,762,269	2,428,414	-	50,061	20,147,867
Inventories	530,789	3,603,821	55,790	17,872,724	1,108,709	-	-	23,171,833
Investment in associates and joint venture	107,226	-	1,023,621	235,634	-	-	10,516,807	11,883,288
Property, plant and equipment	2,296,659	3,446,655	63,686	820,516	24,639,566	-	4,164	31,271,246
Others	4,852,130	1,528,605	647,333	1,631,457	2,534,778	-	1,307,727	12,502,030
	₱14,913,496	₱12,218,481	₱3,308,277	₱38,049,912	₱33,890,556	₱-	₱21,370,037	₱123,750,759
Segment Liabilities								
Customers' advances and deposits	₱5	₱287,308	₱22,689	₱4,619,699	₱-	₱-	₱-	₱4,929,701
Loans payable	104,656	6,445,779	-	18,821,755	11,391,949	-	-	36,764,139
Others	10,927,570	3,281,752	185,118	3,762,901	3,523,194	-	173,307	21,853,842
	₱11,032,231	₱10,014,839	₱207,807	₱27,204,355	₱14,915,143	₱-	₱173,307	₱63,547,682
Other disclosures								
Acquisition of land for future development	₱-	₱-	₱-	₱2,484,872	₱-	₱-	₱-	₱2,484,872
Property, plant and equipment additions (Note 13)	₱1,216,842	₱8,547,904	₱13,945	₱227,445	₱404,050	₱-	₱634	₱10,410,820

*Revenue from construction segment includes sales and service revenue from WRCP.



Year ended December 31, 2012, As Restated (Amounts in Thousands)

	Construction and Others*	Coal Mining	Nickel Mining	Real Estate Development	Power	Water	Parent Company	Total
Revenue	₱15,067,559	₱14,450,155	₱1,923,045	₱9,219,331	₱11,079,789	₱-	₱-	₱51,739,879
Other income (expense) - net	62,653	565,466	(36,319)	373,416	(171,004)	2,339,717	(29,995)	3,103,934
	15,130,212	15,015,621	1,886,726	9,592,747	10,908,785	2,339,717	(29,995)	54,843,813
Cost of sales and services (before depreciation and amortization)	12,990,637	8,502,696	1,335,252	4,434,929	4,314,377	-	-	31,577,891
General and administrative expense (before depreciation and amortization)	277,008	1,967,757	13,854	1,791,977	1,508,413	-	61,199	5,620,208
	13,267,645	10,470,453	1,349,106	6,226,906	5,822,790	-	61,199	37,198,099
EBITDA	1,862,567	4,545,168	537,620	3,365,841	5,085,995	2,339,717	(91,194)	17,645,714
Other income (expenses)								
Finance income (cost) (Notes 26 and 27)	65,588	(109,492)	3,705	(163,293)	(321,509)	-	175,938	(349,063)
Depreciation and amortization (Notes 24 and 25)	(269,356)	(1,345,556)	(127,259)	(168,163)	(1,417,468)	-	(2,040)	(3,329,842)
Pretax income	1,658,799	3,090,120	414,066	3,034,385	3,347,018	2,339,717	82,704	13,966,809
Provision for income tax (Note 29)	382,456	1,439	73,268	928,998	39,589	-	48,804	1,474,554
Net income	₱1,276,343	₱3,088,681	₱340,798	₱2,105,387	₱3,307,429	₱2,339,717	₱33,900	₱12,492,255
Net income attributable to non-controlling interest	₱1,032	₱1,349,069	₱-	₱-	₱1,406,320	₱-	₱-	₱2,756,421
Net income attributable to equity holders	₱1,275,311	₱1,739,612	₱340,798	₱2,105,387	₱1,901,109	₱2,339,717	₱33,900	₱9,735,834
Segment Assets								
Cash	₱2,193,876	₱410,165	₱186,275	₱2,936,722	₱246,054	₱-	₱3,743,950	₱9,717,042
Receivables	4,995,432	1,271,154	184,131	7,444,717	2,630,486	-	152,164	16,678,084
Inventories	219,345	4,486,951	34,546	15,505,470	1,197,900	-	70,949	21,515,161
Investment in associates and joint venture	124,878	-	495,832	115,141	-	-	13,633,403	14,369,254
Property, plant and equipment	1,567,812	3,318,370	248,472	728,753	19,853,793	-	7,032	25,724,232
Others	2,983,482	1,760,785	649,969	2,238,549	1,224,942	-	122,586	8,980,313
	₱12,084,825	₱11,247,425	₱1,799,225	₱28,969,352	₱25,153,175	₱-	₱17,730,084	₱96,984,086
Segment Liabilities								
Customers' advances and deposits	₱-	₱17,645	₱22,685	₱3,315,565	₱-	₱-	₱-	₱3,355,895
Loans payable	25,601	4,913,558	131,360	12,522,481	7,811,362	-	61,724	25,466,086
Others	8,253,009	4,145,032	458,103	3,438,412	2,999,720	-	111,737	19,406,013
	₱8,278,610	₱9,076,235	₱612,148	₱19,276,458	₱10,811,082	₱-	₱173,461	₱48,227,994
Other disclosures								
Acquisition of land for future development	₱-	₱-	₱-	₱1,864,014	₱-	₱-	₱-	₱1,864,014
Property, plant and equipment additions (Note 13)	₱706,489	₱5,036,611	₱111,540	₱233,805	₱83,947	₱-	₱4,107	₱6,176,499

*Revenue from construction segment includes sales revenue from WRCP.



Year ended December 31, 2011, As Restated (Amounts in Thousands)

	Construction and Others*	Coal Mining	Nickel Mining	Real Estate Development	Power	Water	Parent Company	Total
Revenue	₱10,448,670	₱16,230,531	₱2,451,697	₱8,251,128	₱10,420,559	₱-	₱-	₱47,802,585
Other income (expense) - net	43,544	73,894	23,030	264,402	22,488	2,195,061	(3,993)	2,618,426
	10,492,214	16,304,425	2,474,727	8,515,530	10,443,047	2,195,061	(3,993)	50,421,011
Cost of sales and services (before depreciation and amortization)	8,440,977	8,563,516	1,206,001	4,080,030	6,243,269	-	-	28,533,793
General and administrative expense (before depreciation and amortization)	242,018	1,847,738	89,682	1,734,535	1,016,761	-	110,219	5,040,953
	8,682,995	10,411,254	1,295,683	5,814,565	7,260,030	-	110,219	33,574,746
EBITDA	1,809,219	5,893,171	1,179,044	2,700,965	3,183,017	2,195,061	(114,212)	16,846,265
Other income (expenses)								
Finance income (cost) (Notes 26 and 27)	63,665	10,634	(1,852)	(73,801)	(318,222)	-	155,394	(164,182)
Depreciation and amortization (Notes 24 and 25)	(359,361)	(1,720,687)	(99,232)	(71,369)	(841,118)	-	(2,076)	(3,093,843)
Pretax income	1,513,523	4,183,118	1,077,960	2,555,795	2,023,677	2,195,061	39,106	13,588,240
Provision (benefit) for income tax (Note 29)	363,867	(16,153)	160,826	761,062	34,438	-	39,511	1,343,551
Net income	₱1,149,656	₱4,199,271	₱917,134	₱1,794,733	₱1,989,239	₱2,195,061	(₱405)	₱12,244,689
Net income attributable to non-controlling interest	₱51,623	₱1,819,585	₱-	₱-	₱810,527	₱-	₱-	₱2,681,735
Net income attributable to equity holders	₱1,098,033	₱2,379,686	₱917,134	₱1,794,733	₱1,178,712	₱2,195,061	(₱405)	₱9,562,954
Segment Assets								
Cash	₱3,864,940	₱3,752,018	₱891,151	₱2,874,883	₱1,474,432	₱-	₱2,192,424	₱15,049,848
Receivables	2,439,852	1,059,972	80,921	5,012,655	2,225,904	-	4,162	10,823,466
Inventories	186,256	2,997,851	128,624	12,503,426	1,668,518	-	-	17,484,675
Investment in associates and joint venture	69,941	-	-	39,222	-	-	10,759,479	10,868,642
Property, plant and equipment	1,227,398	3,706,971	260,316	657,338	17,562,225	-	3,355	23,417,603
Others	2,268,732	1,043,525	221,318	2,253,681	1,119,162	-	78,669	6,985,087
	₱10,057,119	₱12,560,337	₱1,582,330	₱23,341,205	₱24,050,241	₱-	₱13,038,089	₱84,629,321
Segment Liabilities								
Customers' advances and deposits	₱1,455,311	₱18,481	₱93,833	₱2,042,961	₱-	₱-	₱-	₱3,610,586
Loans payable	84,284	4,719,695	140,288	8,970,788	9,152,807	-	-	23,067,862
Finance lease payable	12,351	-	-	-	-	-	-	12,351
Others	5,142,948	4,674,113	354,750	3,355,689	2,650,963	-	691,394	16,869,857
	₱6,694,894	₱9,412,289	₱588,871	₱14,369,438	₱11,803,770	₱-	₱691,394	₱43,560,656
Other disclosures								
Acquisition of land for future development	₱-	₱-	₱-	₱1,438,978	₱376,605	₱-	₱-	₱1,815,583
Property, plant and equipment additions (Note 13)	₱635,117	₱2,065,988	₱188,037	₱300,356	₱347,790	₱-	₱2,053	₱3,539,341

*Revenue from construction segment includes sales revenue from WRCP.



The Group's management reporting and controlling systems use accounting policies that are the same as those described in Note 2 in the summary of significant accounting policies under PFRS.

The Group measures the performance of its operating segments through a measure of segment profit or loss which is referred to as "EBITDA" in the management and reporting system.

EBITDA is the measure of segment profit (loss) used in segment reporting and comprises gross profit, selling and general administrative expenses, research and non-capitalized development costs, other operating income (expense), net, as well as other financial income (expense), net.

Intersegment revenue is generally recorded at values that approximate third-party selling prices.

Segment assets principally comprise all assets. The industrial business segments' assets exclude income tax assets, assets from defined benefit plans and certain financial assets.

Segment liabilities principally comprise all liabilities. The industrial business segments' liabilities exclude income tax liabilities, liabilities from defined benefit plans and certain financial liabilities.

Geographic Information

Analysis of sales and revenue by geographical location

The financial information about the operations of the coal mining as of December 31, 2013, 2012 and 2011 reviewed by the management follows:

Customer Location	2013	2012	2011
Revenue			
Local	₱5,287,388	₱7,440,134	₱9,041,168
Export	7,286,181	7,010,021	7,189,363
	₱12,573,569	₱14,450,155	₱16,230,531

Substantially all revenue from external customers are from open cut mining and sales of thermal coal. Local and export classification above is based on the geographic location of the customer. Customers on the export sales are significantly from China.

Sales to power company amounted to ₱8.47 billion, ₱3.18 billion and ₱7.01 billion for the years ended December 31, 2013, 2012 and 2011, respectively. All these revenue were from the Coal mining segment.

36. Financial Risk Management Objectives and Policies

The Group's principal financial instruments comprise interest-bearing loans and borrowings. The main purpose of these financial instruments is to raise financing for its operations and capital expenditures. The Group has various other financial assets and liabilities, such as receivables and payables which arise directly from its operations.



The main risks arising from the use of financial instruments are liquidity risk, market risk and credit risk. The Group's BOD reviews and approves policies for managing each of these risks and they are summarized below.

a. Liquidity Risk

Liquidity risk is the risk that an entity will encounter difficulty in meeting obligations associated with financial liabilities. The Group seeks to manage its liquidity profile to be able to service its maturing debts and to finance capital requirements. The Group maintains a level of cash and cash equivalents deemed sufficient to finance operations.

A significant part of the Group's financial assets that are held to meet the cash outflows include cash equivalents and accounts receivables. Although accounts receivables are contractually collectible on a short-term basis, the Group expects continuous cash inflows through continuous production and sale of coal and power generation. In addition, although the Group's short-term deposits are collectible at a short notice, the deposit base is stable over the long term as deposit rollovers and new deposits can offset cash outflows.

Moreover, the Group considers the following as mitigating factors for liquidity risk:

- It has available lines of credit that it can access to answer anticipated shortfall in sales and collection of receivables resulting from timing differences in programmed inflows and outflows.
- It has very diverse funding sources.
- It has internal control processes and contingency plans for managing liquidity risk. Cash flow reports and forecasts are reviewed on a weekly basis in order to quickly address liquidity concerns. Outstanding trade receivables are closely monitored to avoid past due collectibles.
- The Group regularly evaluates its projected and actual cash flows. It also continuously assesses conditions in the financial markets for opportunities to pursue fund-raising activities. Fund-raising activities may include bank loans and capital market issues both on-shore and off-shore which is included in the Group's corporate planning for liquidity management.

The following table summarizes the maturity profile of the Group's financial assets and liabilities as of December 31, 2013 and 2012, based on contractual undiscounted cash flows. The table also analyses the maturity profile of the Group's financial assets in order to provide a complete view of the Group's contractual commitments (amounts in thousands).

	2013					Total
	On Demand	Within 1 year	1-2 years	2-3 years	3-4 years	
Loans and Receivable						
Cash and cash equivalents	₱24,774,495	₱-	₱-	₱-	₱-	₱24,774,495
Receivables						
Trade:						
Real estate	6,884,163	849,257	774,769	626,425	1,612,036	10,746,650
General construction	1,068,705	2,438,659	-	-	-	3,507,364
Mining	2,218,925	-	-	-	-	2,218,925
Electricity sales	3,247,991	-	-	-	-	3,247,991
Merchandising and others	73,054	-	-	-	-	73,054
Receivables from related parties	131,596	-	-	-	-	131,596
Other receivables	181,592	-	-	-	-	181,592
Security deposits	-	407,519	-	-	-	407,519

(Forward)



2013						
	On Demand	Within 1 year	1-2 years	2-3 years	3-4 years	Total
Refundable deposits	₱-	₱252,353	₱-	₱-	₱-	₱252,353
	38,580,521	3,947,788	774,769	626,425	1,612,036	45,541,539
AFS financial assets						
Quoted securities	-	59,200	-	-	-	59,200
Unquoted securities	-	779	950	-	-	1,729
	-	59,979	950	-	-	60,929
Financial assets at FVPL	-	73,150	-	-	-	73,150
Total undiscounted financial assets	38,580,521	4,080,917	775,719	626,425	1,612,036	45,675,618
Other Financial Liabilities						
Short-term debt	-	2,119,296	-	-	-	2,119,296
Accounts and other payables	12,192,024	-	1,496,710	-	-	13,688,734
Payable to related parties	33,992	-	-	-	-	33,992
Liabilities for purchased land	884,182	210,505	86,907	91,180	98,797	1,371,571
Long-term debt	-	2,471,003	3,274,282	5,225,224	6,212,268	17,182,777
Total undiscounted financial liabilities	13,110,237	4,800,804	4,857,899	5,316,404	6,311,065	34,396,370
Liquidity gap	₱25,470,323	(₱719,887)	(₱4,082,180)	(₱4,689,979)	(₱4,699,029)	₱11,279,248
2012						
	On Demand	Within 1 year	1-2 years	2-3 years	3-4 years	Total
Loans and Receivable						
Cash and cash equivalents	₱9,717,042	₱-	₱-	₱-	₱-	₱9,717,042
Receivables						
Trade:						
Real estate	4,492,306	733,280	457,235	391,443	1,756,833	7,831,097
General construction	3,212,704	859,958	-	-	-	4,072,662
Mining	1,453,964	-	-	-	-	1,453,964
Electricity sales	2,626,199	-	-	-	-	2,626,199
Merchandising and others	67,157	-	-	-	-	67,157
Receivable from related parties	187,296	-	-	-	-	187,296
Other receivables	379,661	-	-	-	-	379,661
Security deposits	-	191,390	-	-	-	191,390
Refundable deposits	-	325,859	-	-	-	325,859
	22,136,329	2,110,487	457,235	391,443	1,756,833	26,852,327
AFS financial assets						
Quoted securities	-	86,824	-	-	-	86,824
Unquoted securities	-	1,729	-	-	-	1,729
	-	88,553	-	-	-	88,553
Financial assets at FVPL	-	71,260	-	-	-	71,260
Total undiscounted financial assets	22,136,329	2,270,300	457,235	391,443	1,756,833	27,012,140
Other Financial Liabilities						
Short-term debt	-	632,971	-	-	-	632,971
Accounts payable and other payables	11,523,343	-	1,460,267	-	-	12,983,610
Payable to related parties	61,215	-	-	-	-	61,215
Liabilities for purchased land	928,473	145,935	38,246	1,695	30,070	1,144,419
Long-term debt	5,347,231	2,155,048	3,467,700	2,892,769	5,372,632	19,235,380
Total undiscounted financial liabilities	17,860,262	2,933,954	4,966,213	2,894,464	5,402,702	34,057,595
Liquidity gap	₱4,276,067	(₱663,654)	(₱4,508,978)	(₱2,503,021)	(₱3,645,869)	(₱7,045,455)

b. *Market Risk*

Market risk is the risk of loss to future earnings, to fair values or to future cash flows that may result from changes in the price of a financial instrument. The value of a financial instrument may change as a result of changes in equity prices, market prices, interest rates and foreign currency exchange rates.



The sensitivity analyses have been prepared on the following bases:

- Equity price risk - movements in equity indices
- Market price risk - movements in one-year historical coal prices
- Interest rate risk - market interest rate on unsecured bank loans
- Foreign currency risk - yearly movement in the foreign exchange rates

The assumption used in calculating the sensitivity analyses of the relevant income statement item is the effect of the assumed changes in respective market risks. This is based on the financial assets and financial liabilities held at December 31, 2013 and 2012.

Equity Price Risk

The Group's equity price risk exposure at year-end relates to financial assets whose values will fluctuate as a result of changes in market prices, principally, equity securities classified as AFS financial assets.

Quoted securities are subject to price risk due to changes in market values of instruments arising either from factors specific to individual instruments or their issuers or factors affecting all instruments traded in the market. The Group's market risk policy requires it to manage such risks by setting and monitoring objectives and constraints on investments; diversification plan; and limits on investment in each industry or sector.

The analyses below are performed for reasonably possible movements in the Philippine Stock Exchange (PSE) index for quoted shares and other sources for golf and club shares with all other variables held constant, showing the impact on equity:

	Change in variable		Effect on equity (Other comprehensive income)	
	2013	2012	2013	2012
PSE	0.49%	32.20%	4,469,443	4,636,228
	-0.49%	-32.20%	(4,469,443)	(4,636,228)
Others	23.82%	158.31%	2,754,958	122,610,961
	-23.82%	-158.31%	(2,754,958)	(122,610,961)

The sensitivity analyses shown above are based on the assumption that the movement in PSE composite index and other quoted equity securities will be most likely be limited to an upward or downward fluctuation of 0.49% and 23.82% in 2013, and 32.20% and 158.31% in 2012.

The Group, used as basis of these assumptions, the annual percentage change in PSE composite index and annual percentage change of quoted prices as obtained from published quotes of golf and club shares.

The impact of sensitivity of equity prices on the Group's equity already excludes the impact on transactions affecting the Company's consolidated statements of income.

Commodity Price Risk

Price risk is the risk that the fair value or future cash flows of a financial instrument will fluctuate because of changes in market prices (other than those arising from interest rate risk or currency risk), whether those changes are caused by factors specific to the individual financial instrument or its issuer, or factors affecting all similar financial instruments traded in the market.



The price that the Group can charge for its coal is directly and indirectly related to the price of coal in the world coal market. In addition, as the Group is not subject to domestic competition in the Philippines, the pricing of all of its coal sales is linked to the price of imported coal. World thermal coal prices are affected by numerous factors outside the Group's control, including the demand from customers which is influenced by their overall performance and demand for electricity. Prices are also affected by changes in the world supply of coal and may be affected by the price of alternative fuel supplies, availability of shipping vessels as well as shipping costs. As the coal price is reset on a periodic basis under coal supply agreements, this may increase its exposure to short-term coal price volatility.

There can be no assurance that world coal prices will be sustained or that domestic and international competitors will not seek to replace the Group in its relationship with its key customers by offering higher quality, better prices or larger guaranteed supply volumes, any of which would have a materially adverse effect on the Group's profits.

To mitigate this risk, the Group continues to improve the quality of its coal and diversify its market from power industry, cement industry, other local industries and export market. This will allow flexibility in the distribution of coal to its target customers in such manner that minimum target average price of its coal sales across all its customers will still be achieved (i.e. domestic compared to local). Also, in order to mitigate any negative impact resulting from price changes, it is the Group's policy to set minimum contracted volume for customers with long term supply contracts for each given period (within the duration of the contract) and pricing is negotiated on a monthly basis to even out the impact of any fluctuation in coal prices, thus, protecting its target margin.

The excess volumes are allocated to spot sales which may command different price than those contracted already since the latter shall follow pricing formula per contract. Nevertheless, on certain cases temporary adjustments on coal prices with reference to customers following a certain pricing formula are requested in order to recover at least the cost of coal if the resulting price is abnormally low vis-à-vis cost of production (i.e. abnormal rise in cost of fuel, foreign exchange).

Below are the details of the Group's coal sales to the domestic market and to the export market (as a percentage of total coal sales volume):

	2013	2012
Domestic market	55.43%	55.83%
Export market	44.57	44.17

The following table shows the effect on income before income tax should the change in the prices of coal occur based on the inventory of the Group as of December 31, 2013 and 2012 with all other variables held constant. The change in coal prices used in the simulation assumes fluctuation from the lowest and highest price based on 1-year historical price movements in 2013 and 2012.

Change in coal price	<u>Effect on income before income tax</u>	
	2013	2012
<i>Based on ending coal inventory</i>		
Increase by 42% in 2013 and 30% in 2012	₱1,022,494	₱1,053,009
Decrease by 42% in 2013 and 30% in 2012	(1,022,494)	(1,053,009)

(Forward)



Change in coal price	Effect on income before income tax	
	2013	2012
<i>Based on coal sales volume</i>		
Increase by 42% in 2013 and 30% in 2012	₱5,643,685	₱4,335,047
Decrease by 42% in 2013 and 30% in 2012	(5,643,685)	(4,335,047)

Interest Rate Risk

Interest rate risk is the risk that the fair value or future cash flows of a financial instrument will fluctuate because of changes in market interest rates. The Group's exposure to market risk for changes in interest rates relates primarily to the Group's long-term debt obligations. The Group's policy is to manage its interest cost using a mix of fixed and variable rate debt.

The following table demonstrates the sensitivity of the Group's profit before tax and equity to a reasonably possible change in interest rates, with all variables held constant, through the impact on floating rate borrowings.

	2013		
	Change in basis points	Effect on income before income tax	
		Effect on equity	
Dollar floating rate borrowings	+100 bps	(2,126,831)	(1,488,782)
	-100 bps	2,126,831	1,488,782
Peso floating rate borrowings	+100 bps	110,284	77,199
	-100 bps	110,284	77,199
	2012		
	Change in basis points	Effect on income before income tax	
		Effect on equity	
Dollar floating rate borrowings	+100	(1,960)	(1,372)
	-100	1,960	1,372
Peso floating rate borrowings	+100	(70,252)	(49,177)
	-100	70,252	49,177

The sensitivity analyses shown above are based on the assumption that the interest movements will be more likely be limited to hundred basis points upward or downward fluctuation in both 2013 and 2012. The forecasted movements in percentages of interest rates used were derived based on the Group's historical changes in the market interest rates on unsecured bank loans.

Foreign Currency Risk

Foreign currency risk is the risk that the future cash flows of a financial instrument will fluctuate because of changes in foreign exchange rates. The Group's currency risks arise mainly from cash and cash equivalents, receivables, accounts and other payable, short-term loans and long-term loans of the Group which are denominated in a currency other than the Group's functional currency. The effect on the Group's consolidated statements of income is computed based on the carrying value of the floating rate receivables as at December 31, 2013 and 2012.



The Group does not have any foreign currency hedging arrangements.

The following tables demonstrates the sensitivity to a reasonably possible change in foreign exchange rates, with all variables held constant, of the Company's profit before tax (due to changes in the fair value of monetary assets and liabilities).

	Increase (decrease) in foreign currency rate		Effect on income before income tax (in PHP)	
	2013	2012	2013	2012
US Dollar ¹	+2.02%	+0.49%	(P108,362)	(P18,465)
	-2.02%	-0.49%	108,362	18,465
Japanese Yen ²	+0.61%	+14.89%	(697)	(3)
	-0.61%	-14.89%	697	3
UK Pounds ³	+4.52%	+7.10%	386	550
	-4.52%	-7.10%	(386)	(550)
E.M.U. Euro ⁴	+10.58%	+5.45%	(5,426)	68
	-10.58%	-5.45%	5,426	68
SG Dollar ⁵	+1.88%	—	(391)	—
	-1.88%	—	391	—

1 The exchange rates used were P44.40 to \$1 and P41.05 to \$1 for the year ended December 31, 2013 and 2012, respectively.

2 The exchange rates used were P0.42 to ¥1 and P0.48 to ¥1 for the year ended December 31, 2013 and 2012, respectively.

3 The exchange rates used were P72.90 to £1 and P66.32 to £1 for the year ended December 31, 2013 and 2012, respectively.

4 The exchange rates used were P60.82 to €1 and P54.53 to €1 for the year ended December 31, 2013 and 2012, respectively.

5 The exchange rates used were P35.00 to 1 SG \$ for the year ended December 31, 2013.

Information on the Group's foreign currency-denominated monetary assets and liabilities and their Philippine peso equivalents as of December 31, 2013 and 2012 follows:

	2013					Equivalent in PHP
	U.S. Dollar	Japanese Yen	UK Pounds	E.M.U Euro	SG Dollar	
Financial assets						
Cash and cash equivalents	\$33,406	¥2,740	£117	€23	\$—	P1,494,161
Receivables	16,002	—	—	—	—	710,420
	49,408	2,740	117	23	—	2,204,581
Financial liabilities						
Accounts payable and accrued expenses	(31,443)	(273,932)	—	(866)	(595)	(1,585,534)
Short-term loans	(31,129)	—	—	—	—	(1,381,986)
Long-term loans	(107,911)	—	—	—	—	(4,790,698)
	(170,483)	(273,932)	—	(866)	(595)	(7,758,218)
	(\$121,075)	(¥273,932)	£117	(€843)	(\$595)	(P5,553,637)

	2012					Equivalent in PHP
	U.S. Dollar	Japanese Yen	UK Pounds	E.M.U Euro	SG Dollar	
Financial assets						
Cash and cash equivalents	\$33,406	¥2,740	£117	€23	\$—	P1,494,161
Receivables	16,002	—	—	—	—	710,420
	49,408	2,740	117	23	—	2,204,581

(Forward)



	2012					Equivalent in
	U.S. Dollar	Japanese Yen	UK Pounds	E.M.U Euro	SG Dollar	PHP
Financial liabilities						
Accounts payable and accrued expenses	(\$31,443)	(¥273,932)	£–	(€866)	(\$595)	(₱1,585,534)
Short-term loans	(31,129)	–	–	–	–	(1,381,986)
Long-term loans	(107,911)	–	–	–	–	(4,790,698)
	(170,483)	(273,932)	–	(866)	(595)	(7,758,218)
	(\$121,075)	(¥273,932)	£117	(€843)	(\$595)	(₱5,553,636)

c. *Credit Risk*

Credit risk is the risk that one party to a financial instrument will cause a financial loss for the other party by failing to discharge an obligation. The Group's maximum exposure to credit risk for the components of the statement of financial position at December 31, 2013 and 2012 is the carrying amounts except for real estate receivables. The Group's exposure to credit risk arises from default of the counterparties which include certain financial institutions, real estate buyers, subcontractors, suppliers and various electric companies. Credit risk management involves dealing only with recognized, creditworthy third parties. It is the Group's policy that all counterparties who wish to trade on credit terms are subject to credit verification procedures. The Treasury Department's policy sets a credit limit for each counterparty. In addition, receivable balances are monitored on an ongoing basis. The Group's financial assets are not subject to collateral and other credit enhancement except for real estate receivables and mining receivables from export sales. As of December 31, 2013 and 2012, the Group's exposure to bad debts is not significant.

Real estate contracts

Credit risk is managed primarily through credit reviews and an analysis of receivables on a continuous basis. The Group also undertakes supplemental credit review procedures for certain installment payment structures. The Group's stringent customer requirements and policies in place contributes to lower customer default. Customer payments are facilitated through various collection modes including the use of postdated checks. The credit risk for real estate receivable is also mitigated as the Group has the right to cancel the sales contract and takes possession of the subject house without need for any court action in case of default in payments by the buyer. This risk is further mitigated because the corresponding title to the subdivision units sold under this arrangement is transferred to the buyers only upon full payment of the contract price. The fair value of collateral for installment contracts receivables amounted to ₱12,643.92 million and ₱7,970.00 million in 2013 and 2012, respectively. This resulted to a net exposure of ₱82.23 million and ₱93.00 million in 2013 and 2012, respectively.

Electricity sales

The Group earns substantially all of its revenue from bilateral contracts and WESM and from various electric companies. WESM and the various electric companies are committed to pay for the energy generated by the power plant facilities.

Under the current regulatory regime, the generation rate charged by the Group to WESM is not regulated but is determined in accordance with the WESM Price Determination Methodology (PDM) approved by the Energy Regulatory Commission (ERC) and are complete pass-through charges to WESM. PDM is intended to provide the specific computational formula that will enable the market participants to verify the correctness of the charges being imposed. Likewise, the generation rate charged by the Group to various electric companies is not subject to regulations and are complete pass-through charges to various electric companies.



Mining

The Group evaluates the financial condition of the local customers before deliveries are made to them. On the other hand, export sales are covered by sight letters of credit issued by foreign banks subject to the Group's approval, hence, mitigating the risk on collection.

The Group generally offers 80% of coal delivered payable within thirty (30) days upon receipt of billing and the remaining 20% payable within 15 days after receipt of final billing based on final analysis of coal delivered.

Construction contracts

The credit risk for construction receivables is mitigated by the fact that the Group can resort to carry out its contractor's lien over the project with varying degrees of effectiveness depending on the jurisprudence applicable on location of the project. A contractor's lien is the legal right of the Group to takeover the projects-in-progress and have priority in the settlement of contractor's receivables and claims on the projects-in-progress and have priority in the settlement of contractor's receivables and claims on the projects in progress is usually higher than receivables from and future commitments with the project owners. Trade and retention receivables from project owners are normally high standard because of the creditworthiness of project owners and collection remedy of contractor's lien accorded contractor in certain cases.

With respect to the credit risk arising from the other financial assets of the Group, which comprise cash and cash equivalents, the Group's exposure to credit risk arises from default of the counterparty, with a maximum exposure equal to the carrying amount of these instruments. The Group transacts only with institutions or banks that have proven track record in financial soundness.

Given the Group's diverse base of counterparties, it is not exposed to large concentrations of credit risk.

As of December 31, 2013 and 2012, the credit quality per class of financial assets that were neither past due nor impaired is as follows:

	2013				
	Neither past due nor impaired			Past due or Individually Impaired	Total
	Grade A	Grade B	Grade C		
Cash in bank and cash equivalents	P24,747,312	P-	P-	P-	P24,747,312
Available-for-sale financial assets					
Quoted	59,200	-	-	-	59,200
Unquoted	1,729	-	-	-	1,729
Receivables					
Trade					
Real estate	7,779,769	1,002,013	767,043	1,197,825	10,746,650
General construction	3,057,886	-	-	456,266	3,514,152
Mining	1,863,328	355,597	-	29,743	2,248,668
Electricity sales	3,247,991	-	-	506,538	3,754,529
Merchandising	73,054	-	-	-	73,054
Receivable from related parties	131,596	-	-	-	131,596
Other receivables	127,019	27,804	-	29,517	184,340

(Forward)



2013					
	Neither past due nor impaired			Past due or Individually	Total
	Grade A	Grade B	Grade C	Impaired	
Security deposits	P407,519	P-	P-	P-	P407,519
Refundable deposits	250,714	1,639	-	-	252,353
Total	41,747,117	1,387,053	767,043	2,219,889	46,121,102
Allowance for:					
General construction	-	-	-	6,788	6,788
Mining	-	-	-	29,743	29,743
Electricity sales	-	-	-	506,538	506,538
Others	-	-	-	2,748	2,748
Total allowance	-	-	-	545,817	545,817
Net amount	P41,747,117	P1,387,053	P767,043	P1,674,072	P45,575,285

2012					
	Neither past due nor impaired			Past due or Individually	Total
	Grade A	Grade B	Grade C	Impaired	
Cash in bank and cash equivalents	P9,697,951	P-	P-	P-	P9,697,951
Available-for-sale financial assets					
Quoted	86,824	-	-	-	86,824
Unquoted	1,729	-	-	-	1,729
Receivables					
Trade					
Real estate	5,669,127	730,168	558,945	872,857	7,831,097
General construction	3,557,668	-	-	521,782	4,079,450
Mining	1,224,039	229,925	-	-	1,453,964
Electricity sales	2,626,199	-	-	130,423	2,756,622
Merchandising	67,157	-	-	-	67,157
Receivable from related parties	187,296	-	-	-	187,296
Other receivables	306,821	72,840	-	103,266	482,927
Security deposits	191,390	-	-	-	191,390
Refundable deposits	323,742	2,117	-	-	325,859
Total	23,939,943	1,035,050	558,945	1,628,328	27,162,266
Allowance for:					
General construction	-	-	-	6,788	6,788
Electricity sales	-	-	-	130,423	130,423
Others	-	-	-	103,266	103,266
Total allowance	-	-	-	240,477	240,477
Net amount	P23,939,943	P1,035,050	P558,945	P1,387,851	P26,921,789

Cash and Cash Equivalents

Cash and cash equivalents are short-term placements and working cash fund placed, invested or deposited in foreign and local banks belonging to top ten (10) banks in the Philippines in terms of resources and profitability. These financial assets are classified as Grade A due to the counterparties' low probability of insolvency.

AFS Financial Assets

The Group's AFS financial assets are classified as Grade B because these assets are susceptible to untoward consequences due to the current financial positions of counterparties.



Receivables

Included under Grade A are accounts considered to be of high value and are covered with coal supply, power supply, and construction contracts. The counterparties have a very remote likelihood of default and have consistently exhibited good paying habits. Grade B accounts are active accounts with minimal to regular instances of payment default, due to collection issues. These accounts are typically not impaired as the counterparties generally respond to credit actions and update their payments accordingly. The Group determines financial assets as impaired when probability of recoverability is remote and in consideration of lapse in period which the asset is expected to be recovered.

For real estate receivables, advances to officers and employees and other receivables, Grade A are classified as financial assets with high credit worthiness and probability of default is minimal. While receivables under Grade B and C have favorable and acceptable risk attributes, respectively, with average credit worthiness.

Receivable from related parties are considered Grade A due to the Group's positive collection experience.

Receivables are aged and analyzed on a continuous basis to minimize credit risk associated with these receivables. Receivable balances are monitored on an ongoing basis to ensure timely execution of necessary intervention efforts, such as raising the case to the Group's legal department. Regular monitoring of receivables resulted to manageable exposure to bad debts.

Security and Refundable Deposits

Security and refundable deposits are classified as Grade A since these are to be refunded by the lessor and utility companies at the end of lease term and holding period, respectively, as stipulated in the agreements.

As of December 31, 2013 and 2012, the aging analysis of the Group's financial assets presented per class follows:

	2013					Impaired Assets	Total
	Past due but not impaired						
	<30 days	30-60 days	61-90 days	91-120 days	>120 days		
Receivables							
Trade							
Real estate	₱942,336	₱3,443	₱4,105	₱247,941	₱-	₱-	₱1,197,825
General							
construction	434,836	-	2,981	-	11,661	6,788	456,266
Electricity sales	-	-	-	-	-	506,538	506,538
Mining	-	-	-	-	-	29,743	29,743
Other receivables	29,517	-	-	-	-	-	29,517
	₱1,406,689	₱3,443	₱7,086	₱247,941	₱11,661	₱543,069	₱2,219,889

	2012					Impaired Assets	Total
	Past due but not impaired						
	<30 days	30-60 days	61-90 days	91-120 days	>120 days		
Receivables							
Trade							
Real estate	₱686,682	₱2,509	₱2,991	₱180,675	₱-	₱-	₱872,857
General							
construction	505,877	-	3,460	-	5,657	6,788	521,782
Electricity sales	-	-	-	-	-	130,423	130,423
Other receivables	-	-	-	-	-	103,266	103,266
	₱1,192,559	₱2,509	₱6,451	₱180,675	₱5,657	₱240,477	₱1,628,328



The repossessed lots and residential houses are transferred back to inventory under the account Real estate for sale and held for development and are held for sale in the ordinary course of business. The total of these inventories is ₱700.77 million and ₱204.57 million in 2013 and 2012, respectively. The Group performs certain repair activities on the said repossessed assets in order to put their condition at a marketable state. Costs incurred in bringing the repossessed assets to its marketable state are included in their carrying amounts.

The Group did not accrue any interest income on impaired financial assets.

Fair Value of Financial Instruments

The table below presents a comparison by category of carrying amounts and estimated fair values of all the Group's financial instruments as of December 31, 2013 and 2012:

	2013		2012	
	Carrying Value	Fair Value	Carrying Value	Fair Value
Loans and Receivables				
Cash and cash equivalents				
Cash on hand and in banks	₱8,079,962	₱8,079,962	₱2,875,761	₱2,875,761
Cash equivalents	16,694,533	16,694,533	6,841,281	6,841,281
Receivables - net				
Trade				
Real estate	10,746,650	13,719,814	7,831,097	10,927,246
General construction	3,507,364	3,507,364	4,072,662	4,072,662
Coal mining	2,218,925	2,218,925	1,453,964	1,453,964
Electricity sales	3,247,991	3,247,991	2,626,199	2,626,199
Merchandising and others	73,054	73,054	67,157	67,157
Receivable from related parties	131,596	131,596	187,296	187,296
Other receivables	181,592	181,592	379,661	379,661
Security deposits	407,519	407,519	191,390	191,390
Refundable deposits	252,353	252,353	325,859	325,859
	45,541,539	48,514,703	26,852,327	29,948,476
AFS investments				
Quoted securities	59,200	59,200	86,824	86,824
Unquoted securities	1,729	1,729	1,729	1,729
	60,929	60,929	88,553	88,553
Financial asset at FVPL	73,150	73,150	71,260	71,260
	₱45,675,618	₱48,648,782	₱27,012,140	₱30,108,289
Other Financial Liabilities				
Accounts and other payables	₱13,688,734	₱13,688,734	₱12,983,610	₱12,983,610
Liabilities for purchased land	1,372,477	1,286,856	1,145,324	1,097,633
Payable to related parties	33,992	33,992	61,215	61,215
Short-term and long-term debt - including current portion	36,764,139	36,764,139	24,833,115	24,833,115
Other noncurrent liabilities	1,693,214	1,693,214	1,527,655	1,527,655
	₱53,552,556	₱53,466,935	₱40,550,919	₱40,503,228

Financial assets

The fair values of cash and short-term receivables approximate their carrying amounts as of reporting dates due to the short-term nature of the transactions.

The fair values of installment contracts receivable, loans payable and liabilities for purchased land are based on the discounted value of future cash flows using the applicable rates for similar types of loans and receivables. The discount rates used for installment contracts receivable range from 9.51% to 14.65% in 2013 and 13.29% to 16.5% in 2012.

The fair values of financial assets at FVPL are based on quoted market rates.



Refundable deposits are carried at cost since these are mostly deposits to a utility company as a consequence of its subscription to the electricity services of the said utility company needed for the Group's residential units.

Security deposits other than those pertaining to operating leases and unquoted AFS financial assets - In the absence of a reliable basis of determining fair values due to the unpredictable nature of future cash flows and the lack of suitable methods in arriving at a reliable fair value, these security deposits are carried at cost less impairment allowance, if any.

Financial liabilities

The fair values of accounts and other payables and accrued expenses and payables to related parties approximate their carrying amounts as of reporting dates due to the short-term nature of the transactions.

The discount rates used for loans payable range from 5.25% to 5.75% in 2013 and 5% to 6.5% in 2012. Liabilities for purchased land were discounted at 2.48% to 5.28% in 2013 and 3.28% to 3.62% in 2012.

The carrying values approximated the fair values because of recent and regular repricing of interest rates based on current market conditions. As of December 31, 2013 and 2012, interest rate ranges from 1% to 3% and 1.03% to 4%, respectively.

Estimated fair value of long-term fixed rate loans and liabilities for purchased land are based on the discounted value of future cash flows using the applicable rates for similar types of loans with maturities consistent with those remaining for the liability being valued. For floating rate loans, the carrying value approximates the fair value because of recent and regular repricing (quarterly) based on market conditions.

Fair Value Hierarchy

The Group uses the following hierarchy for determining and disclosing the fair value of financial instruments by valuation technique:

- Level 1: quoted (unadjusted) prices in active markets for identical assets or liabilities
- Level 2: other techniques for which all inputs which have a significant effect on the recorded fair value are observable, either directly or indirectly
- Level 3: techniques which use inputs which have a significant effect on the recorded fair value that are not based on observable market data.

Fair values of real estate receivables, long-term debt, liabilities for purchased land and investment properties are based on level 3 inputs while that of available for sale financial assets and financial assets through profit or loss are from level 1 inputs.

Carrying values of financial instruments, except for long-term debt and liabilities for purchased land, approximate the fair values due to relatively short term nature of the transactions.

Installment contracts receivable, loans payable and liabilities for purchased land

The fair values of installment contracts receivable, loans payable and liabilities for purchased land are based on the discounted value of future cash flows using the applicable rates for similar types of loans and receivables. The discount rates used for installment contracts receivable range from 9.51% to 14.65% in 2013 and 13.29% to 16.5% in 2012.



The discount rates used for loans payable range from 5.25% to 5.75% in 2013 and 5% to 6.5% in 2012. Liabilities for purchased land were discounted at 2.48% to 5.28% in 2013 and 3.28% to 3.62% in 2012.

Financial asset at FVPL

The fair values are based on quoted market prices.

Long-term debt

The carrying values approximated the fair values because of recent and regular repricing of interest rates based on current market conditions. As of December 31, 2013 and 2012, interest rate ranges from 1% to 3% and 1.03% to 4%, respectively.

37. Contingencies and Commitments

Contingencies

Provision for probable legal claims

The Group is contingently liable for lawsuits or claims filed by third parties which are either pending decision by the courts or are under negotiation, the outcomes of which are not presently determinable. In the opinion of management and its legal counsel, the eventual liability under these lawsuits or claims, if any, will not have a material effect on the consolidated financial statements. The information usually required by PAS 37, *Provisions, Contingent Liabilities and Contingent Assets*, is not disclosed on the grounds that it can be expected to prejudice the outcome of these lawsuits, claims and assessments.

Provision for billing disputes

On October 20, 2010, SCPC filed a Petition for dispute resolution (“Petition”) before the Energy Regulatory Commission (ERC) against NPC and PSALM involving over-nominations made by NPC during the billing periods January to June 2010 beyond the 169,000 kW Manila Electric Company (MERALCO) allocation of SCPC, as provided under the Schedule W of the APA.

In its Petition, SCPC sought to recover the cost of energy (a) sourced by SCPC from WESM in order to meet NPC’s nominations beyond the 169,000 kW MERALCO contracted demand, or (b) procured by NPC from the WESM representing energy nominated by NPC in excess of the 169,000 kW limit set in Schedule W, cost of which was charged by PSALM against SCPC. In relation to this, NPC withheld the payments of MERALCO and remitted to SCPC the collections, net of the cost of the outsourced energy.

SCPC has likewise sought to recover interest on the withheld MERALCO payments collected by PSALM that is unpaid to SCPC as of due date, to be charged at the rate of 11% computed from the date of the SCPC’s extrajudicial demand until full payment by PSALM.

During the preliminary conference scheduled on November 25, 2010, the ERC’s hearing officer directed the parties to explore the possibility of settling the dispute amicably. As the parties failed to arrive at a compromise during the prescribed period, hearings resumed with the conduct of preliminary conference on February 23, 2011, without prejudice to the result of any further discussions between the parties for amicable settlement. The ERC set the next hearing for the presentation of witnesses on March 22 and 23, 2011.



In 2010, SCPC made a provision for the total amount withheld by NPC, which amounted to ₱383.29 million. Though a provision has already been made, SCPC has not waived its right to collect the said amount in case the outcome of the dispute resolution would be a favorable settlement for SCPC. The provision will be reversed and an income would be recognized in the "Other income" account upon collection of the said receivable.

On July 6, 2011, the ERC rendered its Decision in favor of SCPC and directed the parties, among others to submit the reconciled computation of the over-nominations and other MERALCO payments withheld by PSALM during the periods January 2010 to June 2010, and for PSALM to return to SCPC the amount computed and reconciled, including the interests thereon a rate of 6% per annum. PSALM filed a Motion for Reconsideration on the Decision which is denied by ERC in an order dated February 13, 2012 due to the lack of merit.

On April 24, 2012, SCPC and PSALM each filed their Compliance submitting the reconciled computations of the over-nominations and other MERALCO payments withheld by PSALM, as agreed upon by the parties, in the principal amount of ₱476 million.

On December 4, 2013, SCPC filed a Motion for Issuance of Writ of Execution praying for the issuance of a Writ of Execution directing PSALM to remit the Principal Amount, including interest of 6% per annum computed from August 4, 2010 until the date of actual payment, as well as the value added tax collected by PSALM from Meralco, pursuant to the ERC's Decision dated July 6, 2011 and Order dated February 13, 2012.

On December 18, 2013, PSALM filed its Comment to SCPC's Motion for Issuance of Writ of Execution essentially arguing that the Commission on Audit must first verify and confirm, through the proper proceeding, the claim against PSALM before PSALM can remit the Principal Amount pursuant to the ERC's judgment.

As of December 31, 2013, decision of Supreme Court regarding the case is still pending resolution.

PSALM's Petition for Review before the Court of Appeals and Supreme Court of the Philippines
Meanwhile, PSALM filed a Petition for Review with Prayer for Temporary Restraining Order and/or Preliminary Injunction with the Court of Appeals on March 30, 2012, questioning the ERC's decision dated July 6, 2011 and Order dated February 13, 2012. On September 4, 2012, the Court of Appeals rendered a Decision, denying PSALM's petition and affirming the related Decision and Order previously issued.

PSALM subsequently filed a Motion for Reconsideration dated September 26, 2012 and seeking the reconsideration of the Decision dated September 4, 2012. SCPC filed its Opposition to PSALM's Motion for Reconsideration on November 5, 2012. Subsequently, the Court of Appeals issued a Resolution denying the Motion for Reconsideration filed by PSALM on November 27, 2012.

On December 27, 2012, PSALM filed a Petition for Review on Certiorari with Prayer for Issuance of Temporary Restraining Order and/or Preliminary Injunction with the Supreme Court.

Subsequently the Supreme Court issued a Resolution dated January 21, 2013 requiring SCPC to file a Comment to PSALM's Petition. Thus, on March 25, 2013, SCPC filed its Comment.



PSALM filed a Motion for Extension to file reply on July 25, 2013, requesting for an additional period of ten (10) days from July 25, 2013, or until August 4, 2013, within which to file its Reply. PSALM subsequently filed its Reply on August 2, 2013.

In a Resolution dated September 30, 2013, the Supreme Court granted PSALM's Motion for Extension to File Reply and noted the filing of PSALM's Reply.

PSALM's Petition has not yet been resolved as of December 31, 2013.

Equipment Rental Agreement

On various dates in 2009 and 2008, SMC entered into Equipment Rental Agreement (the Agreement) with Banco de Oro Rental, Inc. (the Lessor) for the rental of various equipment for a period of twenty (20) months starting on various dates. The Agreement requires for the payment of a fixed monthly rental. The Agreement also requires SMC to pay security deposit which shall be held by the lessor as security for the faithful and timely performance by SMC of all its obligations. Upon termination of the Agreement, the lessor shall return to SMC the security deposit after deducting any unpaid rental and/or other amounts due to lessor. The equipment are, at all times, shall be and remain the sole and exclusive equipment of the lessor, and no title shall pass to SMC.

As of December 31, 2013, the Agreement with the Lessor is terminated.

Lease Commitments

Operating Lease - As Lessor

The Group entered into lease agreements with third parties covering its investment property portfolio (Note 12). The lease agreements provide for a fixed monthly rental with an escalation of 3% to 7% annually and is renewable under the terms and condition agreed with the lessees.

As of December 31, 2013 and 2012, future minimum lease receivables under the aforementioned operating lease (in thousands) are as follows:

	2013	2012
Within one year	₱19,972	₱9,320
After one year but not more than five years	67,154	6,591
More than five years	79,986	798
	₱167,112	₱16,709

Operating Lease - As Lessee

The Group has a noncancellable lease agreement with a various lessors covering office premises, for seven (7) years with escalation rate ranging from 5.00% to 10.00%. The leases are renewable under such terms and conditions that are agreed upon by the contracting parties.

As of December 31, 2013 and 2012, future minimum lease payments under the above mentioned operating lease (in thousands) are as follows:

	2013	2012
Within one year	₱36,107	₱21,304
After one year but not more than five years	51,123	65,846
	₱87,230	₱87,150



Also as discussed in Note 13, the Group entered into a Land Lease Agreement with PSALM for the lease of land in which the plant is situated, for a period of 25 years, renewable for another 25 years with the mutual agreement of both parties. In 2009, the Group paid US\$3.19 million or its peso equivalent ₱150.57 million as payment for the 25 years of rental.

Provisions of the LLA include that the Group has the option to buy the Option Assets upon issuance of an Option Existence Notice (OEN) by the lessor. Optioned assets are parcels of land that form part of the leased premises which the lessor offers for the sale to the lease.

The Group was also required to deliver and submit to the lessor a performance security amounting to ₱34.83 million in the form of Stand-by Letter of Credits. The Performance Security shall be maintained by the Group in full force and effect continuously without any interruption until the Performance Security expiration date. The Performance Security initially must be effective for the period of one year from the date of issue, to be replaced prior to expiration every year thereafter and shall at all times remain valid.

In the event that the lessor issues an OEN and SCPC buys the option assets in consideration for the grant of the option, the land purchase price should be equivalent to the highest of the following and / or amounts: (i) assessment of the Provincial Assessors of Batangas Province; (ii) the assessment of the Municipal or City Assessor having jurisdiction over the particular portion of the leased premises; (iii) the zonal valuation of Bureau of Internal Revenue or, (iv) 21.00 per square meter (dollar). Valuation basis for 1 to 3 shall be based on the receipt of PSALM of the option to exercise notice. The exchange rate to be used should be the Philippine Dealing Exchange rate at the date of receipt of PSALM of the OEN.

The exchange rate to be used should be the Philippine Dealing Exchange rate at the date of receipt of PSALM of the option to exercise notice.

On July 12, 2010, PSALM issued an OEN and granted SCPC the “Option” to purchase the Optioned Assets that form part of the leased premises. SCPC availed of the “Option” and paid the Option Price amounting US\$0.32 million or a peso equivalent of ₱14.72 million exercisable within one year from the issuance of the OEN.

On April 28, 2011, SCPC sent a letter to PSALM requesting for the assignment of the option to purchase a lot with an area of 82,740 sqm in favor of its Parent Company. On May 5, 2011, PSALM approved the assignment. On June 1, 2011, SCPC exercised the land lease option at a purchase price of ₱292.62 million.

On June 1, 2011, SMC and SCPC exercised its option to purchase the Option Asset and subsequently entered into a Deed of Absolute Sale with PSALM for the total consideration of ₱376.61 million.

On October 12, 2011, SCPC reiterated its proposal to purchase the remainder of the Leased Premises not identified as Optioned Assets. One of the salient features of the proposal included the execution of Contract to Sell (CTS) between SCPC and PSALM.

On February 13, 2012, PSALM held off the approval of the proposal to purchase the portion of Calaca Leased Premises not identified as Optioned Assets, subject to further studies. On the same date, PSALM Board has approved SCPC’s request to sub-lease a portion of the Calaca Leased Premises to SLPGC for the purpose of constructing and operating a power plant.



On February 24, 2012, SCPC sent a letter to PSALM for its proposal to handle the titling of Calaca Land.

As of the December 31, 2013, PSALM is pending for any response in connection therewith.

Finance Lease - As Lessee

During 2011, the Group has entered into finance lease agreements for some of its service vehicles and equipment used in its construction activities. The said leased assets are capitalized and depreciated over their estimated useful lives of four (4) years (Note 13). In 2011, finance lease facilities amounting ₱12.35 million was approved at 6.50% interest. In 2012, the Group pre-terminated the finance lease obligation and exercised the option to acquire the service vehicles and equipment used in construction activities.

As of December 31, 2011, the future minimum lease payments under finance lease and the present value of the net minimum lease payments follows:

Within one year	₱8,366
After one (1) year but not more than five (5) years	4,663
<hr/> Total minimum lease payments	<hr/> 13,029
Less finance charges	678
<hr/> Present value of minimum lease payment	<hr/> <hr/> ₱12,351

Contingencies

The Group is contingently liable for lawsuits or claims filed by third parties (substantially labor related and civil cases) that are either pending decision by the courts or are under negotiation, the outcomes of which are not presently determinable. In the opinion of management and its legal counsels, the eventual liability under these lawsuits or claims, if any, will not have a material or adverse effect on the Group's financial position and results of operations. The information usually required by PAS 37, is not disclosed on the grounds that it can be expected to prejudice the outcome of these lawsuits, claims or assessments. No provisions were made during the year.

Capital Commitments

For the year 2011, the Group has capital commitments on acquisition of mining equipment amounting ₱841.07 million in relation to its income tax holiday registration with the BOI. The Group has no capital commitments in 2013 and 2012.

38. Note to Consolidated Statements of Cash Flows

On October 10, 2012, the subscription payable to DMWC amounting ₱379.71 million was cancelled as a result of reduction of DMWC's authorized capital stock. On the same date, the Parent Company has fully settled its due to DMWC amounting ₱234.58 million. The amount from the return of capital amounting ₱150.91 million was applied against a portion of the liability (Note 11).



39. Other Matters

a. EPIRA

In June 2001, the Congress of the Philippines approved and passed into law R.A. No. 9136, otherwise known as the EPIRA, providing the mandate and the framework to introduce competition in the electricity market. EPIRA also provides for the privatization of the assets of NPC, including its generation and transmission assets, as well as its contract with Independent Power Producers (IPPs). EPIRA provides that competition in the retail supply of electricity and open access to the transmission and distribution systems would occur within three years from EPIRA's effective date. Prior to June 2002, concerned government agencies were to establish WESM, ensure the unbundling of transmission and distribution wheeling rates and remove existing cross subsidies provided by industrial and commercial users to residential customers. The WESM was officially launched on June 23, 2006 and began commercial operations for Luzon. The ERC has already implemented a cross subsidy removal scheme. The inter-regional grid cross subsidy was fully phased-out in June 2002. ERC has already approved unbundled rates for Transmission Company (TRANSCO) and majority of the distribution utilities.

Under EPIRA, NPC's generation assets are to be sold through transparent, competitive public bidding, while all transmission assets are to be transferred to TRANSCO, initially a government-owned entity that was eventually being privatized. The privatization of these NPC assets has been delayed and is considerably behind the schedule set by the DOE. EPIRA also created PSALM, which is to accept transfers of all assets and assume all outstanding obligations of NPC, including its obligations to IPPs. One of PSALM's responsibilities is to manage these contracts with IPPs after NPC's privatization. PSALM is also responsible for privatizing at least 70% of the transferred generating assets and IPP contracts within three years from the effective date of EPIRA.

In August 2005, the ERC issued a resolution reiterating the statutory mandate under the EPIRA law for the generation and distribution companies, which are not publicly listed, to make an initial public offering (IPO) of at least 15% of their common shares. Provided, however, that generation companies, distribution utilities or their respective holding companies that are already listed in the Philippine Stock Exchange (PSE) are deemed in compliance. SCPC was already compliant with this requirement given that the Parent Company is a publicly listed company.

WESM

With the objective of providing competitive price of electricity, the EPIRA authorized DOE to constitute an independent entity to be represented equitably by electric power industry participants and to administer and operate WESM. WESM will provide a mechanism for identifying and setting the price of actual variations from the quantities transacted under contracts between sellers and purchasers of electricity.

In addition, the DOE was tasked to formulate the detailed rules for WESM which include the determination of electricity price in the market. The price determination methodology will consider accepted economic principles and should provide a level playing field to all electric power industry participants. The price determination methodology was subject to the approval of the ERC.



In this regard, the DOE created Philippine Electricity Market Corporation (PEMC) to act as the market operator governing the operation of WESM. On June 26, 2006, WESM became operational in the Luzon grid and adopts the model of a “gross pool, net settlement” electricity market.

b. Power Supply Agreement with Manila Electric Company (MERALCO)

On December 20, 2011, SCPC entered into a new power supply agreement with MERALCO, a distributor of electric power, which took effect in December 26, 2011 and shall have a term of seven (7) years, which may be extended by the parties for another three (3) years.

SCPC will be providing MERALCO with an initial contracted capacity of 210 MW and will be increased to 420 MW upon the commercial operation of the plant’s Unit 1.

On March 12, 2012, MERALCO filed an application for the *Approval of the Power Supply Agreement (PSA) between MERALCO and SCPC, with a Prayer for Provisional Authority*, docketed as ERC Case No. 2011-037 RC.

In the said application, MERALCO alleged and presented on the following: a.) the salient provisions of the PSA; b.) payment structure under the PSA; c.) the impact of the approval of the proposed generation rates on MERALCO’s customers; and d.) the relevance and urgent need for the implementation of the PSA.

On December 17, 2012, the Commission (ERC) issued a Decision approving with modification of the ERC Case No. 2012-037 RC.

c. Clean Air Act

On November 25, 2000, the Implementing Rules and Regulations (IRR) of the Philippine Clean Air Act (PCAA) took effect. The IRR contains provisions that have an impact on the industry as a whole and on SCPC in particular, that need to be complied with within 44 months (or until July 2004) from the effectivity date, subject to the approval by DENR. The power plant of SCPC uses thermal coal and uses a facility to test and monitor gas emissions to conform with Ambient and Source Emissions Standards and other provisions of the Clean Air Act and its IRR. Based on SCPC’s initial assessment of its power plant’s existing facilities, SCPC believes that it is in full compliance with the applicable provisions of the IRR of the PCAA.

d. Contract for the Fly Ash of the Power Plant

On October 20, 1987, NPC and Pozzolanic Australia Pty, Ltd. (“Pozzolanic”) executed the Contract for the Purchase of Fly Ash of the Power Plant (the “Pozzolanic Contract”). Under the Pozzolanic Contract, Pozzolanic was given the right to sell, store, process, remove or otherwise dispose of all fly ash produced at the first unit of the Power Plant. It was also granted the first option to purchase fly ash, under similar terms and conditions, from the second unit of the Power Plant that NPC may construct. It may also exercise the exclusive right of first refusal to purchase fly ash from any new coal-fired power plants which will be put up by NPC.



The Pozzolan Contract is effective for a period of five consecutive five-year terms from its signing, or a period of 25 years from October 20, 1987 or until 2012, subject to cancellation by NPC upon default or any breach of contract by Pozzolan. At the end of each five-year term, the parties will agree to assess and evaluate the Pozzolan Contract, and if necessary, revise, alter, modify the same upon their mutual consent.

The Philippine Government has determined the provision of the Pozzolan Contract which grants Pozzolan the exclusive right of first refusal to purchase fly ash from the second unit of the Power Plant and from any coal-fired power plant put up by NPC after the execution of the Pozzolan Contract as invalid. This is the subject of a case filed by Pozzolan and pending before the regional trial court of Quezon City as of December 31, 2011.

On April 30, 2012, the Group and Pozzolan sealed its new contract valid and effective for a period of fifteen (15) years beginning February 1, 2012. Pozzolan, as agreed, shall purchase One Hundred (100 %) percent of fly ashes produced or generated by the Power Plant.

e. Temporary Restraining Order on MERALCO

On December 23, 2013, the Supreme Court (SC) issued a temporary restraining order (TRO) to MERALCO enjoining it from increasing the generation rates it charges to its consumers arising from the increased generation costs from its suppliers for the supply month of November 2013. The said TRO also enjoined the Energy Regulatory Commission (ERC) from implementing its December 9, 2013 Order authorizing MERALCO to stagger the collection of its increased generation costs for the supply month of November 2013. The TRO was for a period of 60 days from December 23, 2013 to February 21, 2014.

On January 10, 2014, the SC impleaded MERALCO's suppliers of generation costs, including PEMC, the operator of the wholesale electricity supply market (WESM), as parties-respondents in the cases.

On February 18, 2014, the SC extended the TRO for another 60 days up to April 22, 2014.

As a result of the TRO, MERALCO has not been able to fully bill its consumers for the generation costs for the supply month of November 2013; and in turn, it has not been able to fully pay its suppliers of generation costs, including PEMC.

On March 11, 2014, the ERC released its ERC Order (Case No 2014-021MC, dated March 3, 2014) voiding the Luzon WESM prices during the November and December 2013 supply months and declaring the imposition of regulated prices in lieu thereof. PEMC was hereby directed within 7 days from receipt of the Order to calculate these regulated prices and implement the same in the revised WESM bills of the concerned distribution utilities in Luzon for the November and December 2013 supply months for their immediate settlement, except for MERALCO whose November 2013 WESM bill shall be maintained in compliance with the TRO issued by the SC.

Pending PEMC's actions and/or recalculation of the WESM prices for the November and December 2013 supply months in accordance with the ERC Order, and its effect on each generation company that trade in the WESM, the Group estimated its exposure to the said ERC order. Please see judgments and estimates in Note 3.



f. Transfer of Rights

On December 4, 2007, the BOD of DMCI Masbate authorized the transfer to DMCI Masbate, all rights, interests, and obligations over applications, permits, registrations, certifications, endorsements and approvals which DMCI Masbate may have applied with and secured from the Department of Energy, BOI, Bureau of Customs, and other agencies of government, and those from private entities and financial institutions relative to the power project in Masbate, such as but not limited to the Coal Supply Agreement (CSA) executed with SMC dated September 4, 2007, and BOI executed last September 17, 2007.

g. Power Supply Agreement with Masbate Electric Cooperative, Inc. (MASELCO)

On May 4, 2007, MASELCO and DMCI Masbate entered into a Power Supply Agreement (PSA) wherein DMCI Masbate shall deliver a guaranteed dependable capacity of 13,000 kW which MASELCO may dispatch for its load and ancillary services requirements.

The PSA has a term commencing on the date of its execution and expiring on the last day of the fifteenth (15th) year of the commercial operations period as provided therein, unless extended or earlier terminated. The commercial operations period shall commence not later than eighteen (18) months from effective date. MASELCO shall only pay for actual energy delivered, not on a take or pay basis, except in extraordinary circumstances as provided in the PSA. In exceptional circumstances, payments shall be based on a pre-defined net expected energy rate.

h. Subsidy Agreement between National Power Corporation (NPC), Masbate Electric Cooperative (MASELCO) and DMCI Masbate Power Corporation

In 2008, DMCI Masbate, National Power Corporation (NPC) and MASELCO have signed the Subsidy Agreement which governs the availment by the Company of the Missionary Electrification Subsidy (ME Subsidy) as New Power Provider (NPP) in the province of Masbate.

The agreement shall take effect from the time of execution until expiration of the PSA or termination of the Subsidy Agreement, as provided under Section 8 of the Subsidy Agreement, whichever comes earlier.

The ME Subsidy shall be computed as the difference between the True Cost of Generation computed under the PSA and the Socially Acceptable Generation Rate (SAGR) paid by Maselco. The amount of the ME Subsidy shall be taken from the Universal Charge-Missionary Electrification (UC-ME) fund being maintained by NPC.

i. Reinstated and Amended Subsidy Agreement between National Power Corporation, Masbate Electric Cooperative and DMCI Masbate Power Corporation

On October 27, 2010, in line with the Transitory Agreement with MASELCO, DMCI Masbate, NPC and MASELCO signed the Reinstated and Amended Subsidy Agreement. This agreement will entitle DMCI Masbate to avail of the ME Subsidy while the Transitory Agreement is effective. Moreover, this agreement includes an additional provision pertaining to Financing of Power Station and an amendment of a provision pertaining to Payment of Subsidy Fee and True-Up Adjustments.



j. Amended Power Supply Agreement and Transitory Supply Agreement

In June 8, 2010, an Application was filed with ERC for the approval of the PSA, as amended by the Reinstated and Amendment to the Power Supply Agreement and Transitory Supply Agreement (TSA), and Supplement to the Transitory Agreement as well as the New Power Provider-True Cost Generation Rate (“NPP-TCGR”). The ERC, in its Order of July 12, 2010, provisionally approved the Application filed by MASELCO and DMCI Masbate, and subsequently, issued another Order on July 4, 2011, extending the provisional authority granted until revoked or made permanent.

Meanwhile, upon MASELCO’s request, DMCI Masbate constructed two (2) satellite power plants: a 1 x 2MW diesel-fired gensets and 1 x 1 MW diesel-fired gensets in the Municipality of Aroroy and another 2 X 1 MW diesel-fired gensets and 1 x 2 diesel-fired gensets in the Municipality of Cataingan. The construction of such power plants significantly improved and stabilized the power supply in the province of Masbate.

In view of the aforementioned improvements and developments, the existing tariff rates as contained in the PSA and its Supplements as approved by the ERC no longer reflect the true and actual cost of power generation in the Province. Thus, realizing the need to adjust the existing tariff schedule to reflect the actual costs of the power generated during the remaining term of the PSA, MASELCO and DMCI Masbate entered into a Memorandum of Agreement (“MOA”) on August 3, 2011, incorporating therein the revised rate formula computation and a provision for prompt payment discount.

On January 28, 2013, ERC issued a Decision for the approval with modification of the application for the Power Supply Agreement (PSA) and the supplemental Memorandum of Agreement (MOA) both filed by MASELCO and DMPC.

On June 3, 2013, ERC issued an Order authorizing DMCI Masbate to recover from the Universal Charge for Missionary Electrification (UC-ME) the amount of ₱75.16 million, representing the difference between the final and provisionally approved rates, in three (3) monthly payments of ₱25.05 million (plus the applicable VAT) starting its June 2013 billing period.

k. ERC Approval of 3rd - 6th Deferred Accounting Adjustment (DAA) for Generation Rate Adjustment Mechanism (GRAM) and Incremental Currency Exchange Rate Adjustment (ICERA)

On January 31, 2011, ERC issued an Order authorizing the National Power Corporation-Small Power Utilities Group (NPC-SPUG) to recover the DAA for 3rd GRAM amounting to ₱0.9492/kWh starting the January 2011 billing period. Furthermore, the Commission thru its decision dated August 1, 2011 hereby authorized to recover the additional DAA for 4th to 6th GRAM and ICERA amounting to ₱1.4282/kWh for the billing period January 25, 2012 to June 25, 2012. The said decision on the DAA for the 3rd to 6th GRAM and ICERA was implemented effective January 2012 billing month as an addition to the existing SAGR of MASELCO. Subsequently, the ERC issued an order dated 30 July 2012 amending its earlier decision on the charging of the DAA for the 4th to 6th GRAM and ICERA that starting August 2012 billing, the said DAA will no longer be included in the SAGR of all distribution utilities located in the off-grid areas including MASELCO.



l. Power Supply Agreement with Palawan Electric Cooperative, Inc.(PALECO)

On July 25, 2012, PALECO and the Group entered into a PSA wherein the Group shall deliver a guaranteed dependable capacity of up to 25 MW which PALECO may dispatch for its active power requirements, frequency regulation, contingency reserve, spinning reserve and voltage regulation control.

The PSA has a term commencing on the effective date of its execution and expiring on the last day of the fifteenth (15th) year of the commercial operations period counted from the commercial operations date as provided therein, unless extended or earlier terminated. The effective date shall be no later than one hundred eighty (180) days from issuance of Notice of Award. PALECO shall only pay for actual energy delivered, except otherwise expressly provided therein.

m. Memorandum of Agreement (MOA) with PALECO

On October 4, 2012, due to an impending power shortage in Puerto Princesa City and some municipalities in the Province of Palawan, and upon the request of PALECO, the Group entered into a MOA with PALECO wherein the Group undertakes to construct, commission, operate and maintain at least 5 MW generated dependable capacity diesel generating sets by December 1, 2012, ahead of the date of effectivity of the Group's obligation to deliver power under the executed PSA between the parties.

On November 26, 2012, the ERC issued an Order provisionally approving the MOA between the Group and PALECO. The order further states that the Group is entitled to avail the subsidy for the UC-ME fund.

The MOA shall continue to be in full force and effect until August 31, 2013, unless earlier terminated or amended by mutual agreement of the parties.

n. Subsidy Agreement with NPC and PALECO

On December 2012, the Group, NPC and PALECO are in the process of signing the Subsidy Agreement which governs the availment by the Group of the ME Subsidy as NPP in the province of Palawan.

The ME Subsidy shall be computed as the difference between the True Cost of Generation computed under the PSA and the SAGR paid by PALECO. The amount of the ME Subsidy shall be taken from the UC-ME fund being maintained by NPC.

o. MOA with Benguet Corp Nickel Mines, Inc. (BNMI)

In March 2010, the DMCI Mining Corporation and BNMI, an affiliate of BC, agreed to establish and maintain a Mine Rehabilitation Fund as a reasonable environmental deposit to ensure the availability of funds for its satisfactory compliance with the commitments and performance of activities stipulated in its EPEP/AEPEP during a specific project phase. This remains in effect in 2013.



- p. Memorandum of Agreement (MOA) with Fil-Asian Strategic Resources and Properties Corporation (Fil-Asian)

In March 2007, the Parent Company, entered into a MOA with Fil-Asian wherein Fil-Asian appointed the former to exclusively undertake mining operations in the municipalities of Sta. Cruz and Candelaria, Province of Zambales. The Parent Company assigned DMC to undertake the mining operations covered by the MOA at the time the latter has established its corporate identity. The annual work program shall aim to accomplish five (5) million tons of ore in five (5) years. This agreement shall terminate upon the DMC's extraction of five (5) million tons of laterite from the property, or the expiration of five (5) years from the date of the execution of this agreement, whichever comes first.

On March 3, 2011, Fil-Asian assigned and transferred to ZDMC (Zambales Diversified Metals Corporation) all rights to the MOA stated above. Subject to its submission of a Work Plan to include mining and environmental plans and to be approved by ZDMC and to the conditions of this Agreement, DMC shall continue to be allowed by ZDMC to undertake mining operations. This Agreement shall commence on the date of its execution and shall be effective until December 31, 2012.

DMC and ZDMC mutually agreed to terminate the MOA in May 2012, but resumed mining operations in October 2012.

- q. Administration Agreement with ZDMC

In October 2012, the Company entered into an administration agreement with ZMDC, in which the Company undertakes, in behalf of ZDMC, the trucking and mining of nickel laterite ore.

Mining services revenue arising from the said agreement amounted to ₱163.92 million in 2013.

40. Events After the Reporting Period

Acquisition of additional shares in ENK Plc.

On March 25, 2014, the Parent Company purchased from D&A Income Ltd. the remaining 40% interest in ENK for approximately ₱3.12 billion. ENK is a nickel laterite development and production company focused on developing the Acoje and Zambales chromite projects in the Philippines. Upon completion of the acquisition, ENK became a wholly owned subsidiary of the Parent Company.



INDEPENDENT AUDITORS' REPORT ON SUPPLEMENTARY SCHEDULES

The Stockholders and the Board of Directors
DMCI Holdings, Inc.
3rd Floor, Dacon Building
2281 Don Chino Roces Avenue
Makati City

We have audited in accordance with Philippine Standards on Auditing, the consolidated financial statements of DMCI Holdings, Inc. and Subsidiaries (the Group) as at December 31, 2013 and 2012 and for each of the three years in the period ended December 31, 2013, included in this Form 17-A, and have issued our report thereon dated April 3, 2014. Our audits were made for the purpose of forming an opinion on the consolidated financial statements taken as a whole. The schedules listed in the Index to the Consolidated Financial Statements and Supplementary Schedules are the responsibility of the Group's management. These schedules are presented for purposes of complying with the Securities Regulation Code Rule No. 68, As Amended (2011) and are not part of the consolidated financial statements. These schedules have been subjected to the auditing procedures applied in the audit of the consolidated financial statements and, in our opinion, fairly state in all material respects, the information required to be set forth therein in relation to the consolidated financial statements taken as a whole.

SYCIP GORRES VELAYO & CO.

Cyril Jasmin B. Valencia
Cyril Jasmin B. Valencia
Partner
CPA Certificate No. 90787
SEC Accreditation No. 1229-A (Group A),
May 31, 2012, valid until May 30, 2015
Tax Identification No. 162-410-623
BIR Accreditation No. 08-001998-74-2012,
April 11, 2012, valid until April 10, 2015
PTR No. 4225226, January 2, 2014, Makati City

April 3, 2014



DMCI HOLDINGS, INC. AND SUBSIDIARIES
INDEX TO CONSOLIDATED COMPANY FINANCIAL STATEMENTS AND
SUPPLEMENTARY SCHEDULES

CONSOLIDATED COMPANY FINANCIAL STATEMENTS

Statement of Management's Responsibility for Consolidated Financial Statements

Report of Independent Auditors' Report

Consolidated Statements of Financial Position as of December 31, 2013 and 2012 and
January 1, 2012

Consolidated Statements of Comprehensive Income for the Years Ended
December 31, 2013, 2012 and 2011

Consolidated Statements of Changes in Equity for the Years Ended
December 31, 2013, 2012 and 2011

Consolidated Statements of Cash flows for the Years Ended
December 31, 2013, 2012 and 2011

Notes to Consolidated Financial Statements

SUPPLEMENTARY SCHEDULES

Report of Independent Auditors on Supplementary Schedules

- I. Schedules required by Annex 68-E
 - A. Financial Assets (Current Marketable Equity and Debt Securities and Other Short-Term Cash Investments)
 - B. Amounts Receivable from Directors, Officers, Employees, Related Parties and Principal Stockholders (Other than Related Parties)
 - C. Amounts Receivable from Related Parties which are Eliminated during the Consolidation of Financial Statements
 - D. Intangible Assets
 - E. Long-term Debt
 - F. Indebtedness to Related Parties
 - G. Guarantees of Securities of Other Issuers
 - H. Capital Stock
- II. Schedule of all of the effective standards and interpretations (Part 1, 4J)
- III. Reconciliation of Retained Earnings Available for Dividend Declaration (Part 1, 4C; Annex 68-C)
- IV. Map of the relationships of the companies within the group (Part 1, 4H)
- V. Schedule of Financial Ratios



DMCI HOLDINGS, INC. AND SUBSIDIARIES**SUPPLEMENTARY INFORMATION AND DISCLOSURES REQUIRED ON SRC RULE 68 AS AMENDED
DECEMBER 31, 2013**

Philippine Securities and Exchange Commission (SEC) issued the amended Securities Regulation Code Rule SRC Rule 68 which consolidates the two separate rules and labeled in the amendment as “Part I” and “Part II”, respectively. It also prescribed the additional information and schedule requirements for issuers of securities to the public.

Below are the additional information and schedules required by SRC Rule 68, as Amended (2011), that are relevant to the Group. This information is presented for purposes of filing with the SEC and is not required part of the basic financial statements.

Schedule A. Financial Assets

Name of issuing entity and association of each issue	Number of shares or principal amount of bonds and notes	Amount shown in the balance sheet	Value based on market quotation at end of reporting period	Income received and accrued
Manila Electric Company	38,553	₱9,664,076	₱9,664,076	
Manila Southwoods Golf-Academy	3	1,330,000	1,330,000	
Subic Bay Yatch Club	2	400,000	400,000	
Manila Golf and Country Club	1	30,000,000	30,000,000	
Capitol Hills Golf and Country Club	1	30,000	30,000	
Canlubang Golf and Country Club	1	500,000	500,000	
Mabuhay Vinyl Corp.	34,889	77,104	77,104	
Alabang Country Club Inc.	1	2,200,000	2,200,000	
Wack Wack Golf & Country Club	1	15,000,000	15,000,000	
Wirerope Corporation of the Philippines	19,925	6,432,811	6,432,811	

(Forward)



Name of issuing entity and association of each issue	Number of shares or principal amount of bonds and notes	Amount shown in the balance sheet	Value based on market quotation at end of reporting period	Income received and accrued
DMC Conex Freight Services, Inc.	1	₱661,014	₱661,014	
Northwoods Development Corporation	1	650,000	650,000	
Bayantel	1	400,000	400,000	
Philippine Columbian Association	1	16,896	16,896	
Purefoods Preferred Shares	70,000	73,150,000	73,150,000	₱4,200,000

Schedule B. Amounts Receivable from Directors, Officers, Employees, Related Parties and Principal Stockholders (other than related parties)

Name and Designation of debtor	Balance at beginning of period	Additions	Amounts collected	Amounts written off	Current	Not current	Balance at end of period
--------------------------------	--------------------------------	-----------	-------------------	---------------------	---------	-------------	--------------------------

Not applicable. The Group's receivables from officers and employees pertain to ordinary purchases subject to usual terms, travel and expense advances and other transactions arising from the Group's ordinary course of business.



Schedule C. Amounts Receivable from/Payable to Related Parties which are Eliminated during the Consolidation of Financial Statements

The following is the schedule of receivables from related parties, which are eliminated in the consolidated financial statements as at December 31, 2013:

Entity with Receivable Balance	Name of Entity with Payable Balance	Due from related party	Due to related party
D.M. Consunji, Inc.	Semirara Mining Corporation	₱736,886,254	(₱736,886,254)
D.M. Consunji, Inc.	Southwest Luzon Power Generation Corporation	530,379,345	(530,379,345)
Beta Electric Corporation	D.M. Consunji, Inc.	401,278,903	(401,278,903)
Southwest Luzon Power Generation Corporation	D.M. Consunji, Inc.	383,721,078	(383,721,078)
Project Developers, Inc.	DMCI Homes, Inc.	284,288,111	(284,288,111)
D.M. Consunji, Inc.	Beta Electric Corporation	209,705,193	(209,705,193)
Semirara Mining Corporation	D.M. Consunji, Inc.	166,191,976	(166,191,976)
Riviera Land Corporation	Project Developers, Inc.	86,000,628	(86,000,628)
Hampstead Gardens Corporation	Project Developers, Inc.	75,880,220	(75,880,220)
D.M. Consunji, Inc.	Sem-Calaca Power Corporation	66,906,302	(66,906,302)
DMCI Power Corporation	Semirara Mining Corporation	66,138,356	(66,138,356)
Project Developers, Inc.	DMCI Hotel Property Management, Inc.	50,096,774	(50,096,774)
DMCI Power Corporation	Sem-Calaca Power Corporation	40,283,914	(40,283,914)
DMCI Holdings, Inc.	DMCI Power Corporation	21,275,000	(21,275,000)
D.M. Consunji, Inc.	DMCI Power Corporation	17,597,771	(17,597,771)
Semirara Mining Corporation	DMCI Mining Corporation	8,717,043	(8,717,043)
Wirerope Corporation	D.M. Consunji, Inc.	5,975,981	(5,975,981)
D.M. Consunji, Inc.	DMCI Masbate Power Corporation	5,828,127	(5,828,127)
Riviera Land Corporation	DMCI Homes, Inc.	5,663,401	(5,663,401)
Sem-Calaca Power Corporation	D.M. Consunji, Inc.	4,456,536	(4,456,536)
Hampstead Gardens Corporation	DMCI Homes, Inc.	2,399,955	(2,399,955)
DMCI Palawan Power Corporation	DMCI Power Corporation	2,817,716	(2,817,716)
DMCI Homes, Inc.	Riviera Land Corporation	2,545,103	(2,545,103)
Beta Electric Corporation	Raco Haven Automation Philippines, Inc.	1,528,767	(1,528,767)
D.M. Consunji, Inc.	DMCI Homes, Inc.	850,564	(850,564)
D.M. Consunji, Inc.	DMCI Mining Corporation	811,509	(811,509)
Semirara Mining Corporation	DMCI Masbate Power Corporation	659,515	(659,515)
DMCI Homes, Inc.	D.M. Consunji, Inc.	486,026	(486,026)
DMCI Power Corporation	DMCI Palawan Power Corporation	248,854	(248,854)
D.M. Consunji, Inc.	Wirerope Corporation of the Philippines, Inc.	133,933	(133,933)
D.M. Consunji, Inc.	DMCI Hotel Property Management, Inc.	35,546	(35,546)
DMCI Holdings, Inc.	Semirara Mining Corporation	30,000	(30,000)
DMCI Masbate Power Corporation	DMCI Mining Corporation	6,000	(6,000)

As of December 31, 2013, the balances above of due from and due to related parties are expected to be realized and settled within twelve months from the reporting date and are classified under current assets and liabilities. There were no amounts written off during the year.



Schedule D. Intangible Asset

Description	Beginning balance	Additions at cost	Charged to costs and expenses	Charged to other accounts	Other changes	Ending balance
Software cost	₱49,945,429	₱20,378,180	(₱36,725,875)	₱—	₱—	₱33,597,734

See Note 14 of the Consolidated Financial Statements.



Schedule E. Long-term Debt

Below is the schedule of long-term debt of the Group:

Title of issue and type of obligation	Amount authorized by indenture	Interest rates	Maturity date	Number of periodic installments	Amount shown under caption "Current portion of long-term debt" in related balance sheet	Amount shown under caption "Long-term debt" in related balance sheet
Mortgage payable	₱5,342,447,546	PDST-F benchmark yield for 3-month treasury securities + 1.75%	May 2017	Payable in twenty-five (25) equal consecutive quarterly installments commencing on May 2011	₱1,519,639,144	₱3,822,808,402
Mortgage payable	5,675,501,237	PDST-F benchmark yield for 3-month treasury securities + 1.00%	May 2022	Payable in twenty-five (27) equal consecutive quarterly installments commencing on November 24, 2015	–	5,675,501,237
Bank loans	320,373,016	Floating rate payable quarterly and in arrears, to be repriced every 90 days	January 2015	Principal repayable in bullet at the end of three (3) years from drawdown date	–	320,373,016
Bank loans	21,309,600	Floating rate payable quarterly and in arrears, to be repriced every 90 days	January 2015	Principal repayable in bullet at the end of three (3) years from drawdown date	–	21,309,600
Bank loans	97,713,395	Floating rate to be repriced every 90 days	March 2014	Principal repayable at maturity date	97,713,395	–
Bank loans	52,119,730	Floating rate to be repriced every 90 days	April 2014	Principal repayable at maturity date	52,119,730	–
Bank loans	144,550,120	Floating rate to be repriced every 90 days	July 2014	Principal repayable at maturity date	144,550,120	–
Bank loans	127,502,440	Floating rate to be repriced every 90 days	August 2014	Principal repayable at maturity date	127,502,440	–
Bank loans	9,544,925	Floating rate to be repriced every 90 days	September 2014	Principal repayable at maturity date	9,544,925	–
Bank loans	97,979,765	Floating rate to be repriced every 90 days	November 2014	Principal repayable at maturity date	97,979,765	–
Bank loans	176,779,079	Floating rate to be repriced every 90 days	March 2015	Principal repayable at maturity date	–	176,779,079

(Forward)



Title of issue and type of obligation	Amount authorized by indenture	Interest rates	Maturity date	Number of periodic installments	Amount shown under caption "Current portion of long-term debt" in related balance sheet	Amount shown under caption "Long-term debt" in related balance sheet
Bank loans	₱290,691,985	Floating rate to be repriced every 90 days	May 2015	Principal repayable at maturity date	₱—	₱290,691,985
Bank loans	18,632,435	Floating rate to be repriced every 90 days	June 2015	Principal repayable at maturity date	—	18,632,435
Bank loans	215,493,330	Floating rate to be repriced every 90 days	April 2015	Principal repayable at maturity date	—	215,493,330
Bank loans	14,739,140	Floating rate to be repriced every 90 days	July 2015	Principal repayable at maturity date	—	14,739,140
Bank loans	1,497,566,016	Floating rate to be repriced every 90 days	December 2016	Principal repayable at maturity date	—	1,497,566,016
Bank loans	102,108,500	Floating rate, aggregate of the margin (1.20%) and LIBOR, to be repriced every 90 to 180 days	December 2014	Principal repayable in semi-annual installments commencing on the 12 th month after the date of the Agreement until date of final maturity	102,108,500	—
Bank loans	104,328,250	Floating rate, aggregate of the margin (1.20%) and LIBOR, to be repriced every 90 to 180 days	June 2015	Principal repayable in semi-annual installments commencing on the 12 th month after the date of the Agreement until date of final maturity	—	104,328,250
Bank loans	104,328,250	Floating rate, aggregate of the margin (1.20%) and LIBOR, to be repriced every 90 to 180 days	December 2015	Principal repayable in semi-annual installments commencing on the 12 th month after the date of the Agreement until date of final maturity	—	104,328,250

(Forward)



Title of issue and type of obligation	Amount authorized by indenture	Interest rates	Maturity date	Number of periodic installments	Amount shown under caption "Current portion of long-term debt" in related balance sheet	Amount shown under caption "Long-term debt" in related balance sheet
Bank loans	₱621,530,000	Floating rate, aggregate of the margin (1.20%) and LIBOR, to be repriced every 90 to 180 days	June 2016	Principal repayable in semi-annual installments commencing on the 12 th month after the date of the Agreement until date of final maturity	₱—	₱621,530,000
Bank loans	621,530,000	Floating rate, aggregate of the margin (1.20%) and LIBOR, to be repriced every 90 to 180 days	December 2016	Principal repayable in semi-annual installments commencing on the 12 th month after the date of the Agreement until date of final maturity	—	621,530,000
Bank loans	151,877,594	Floating rate	September 2015	Principal payable on the date of maturity	—	151,877,594
Corporate notes	1,960,000,000	7.220%	5 years	1% every year	20,000,000	1,940,000,000
Corporate notes	2,940,000,000	7.890%	5 years	1% every year	30,000,000	2,910,000,000
Corporate notes	1,000,000,000	6.080%	7 years	7th to 27th Quarter from issue date	10,000,000	990,000,000
Corporate notes	4,000,000,000	5.250%	8 years	9th to 30th Quarter from issue date	—	4,000,000,000
Corporate notes	5,000,000,000	5.000%	8 years	8th to 29th Quarter from issue date	—	5,000,000,000
Discount on note payable	(109,494,500)	N/A	N/A	N/A	(21,272,313)	(88,222,187)
Receivable with recourse	4,031,250,005	PDST-F Issue Date and ending three (3) months after such Issue Date, and every three (3) months thereafter	Various maturities from 2016 to 2020	Payments shall be made in each tranche is equal to 1% every year from the issue date and the balance payable at maturity	1,184,421,796	2,846,828,209

(Forward)



Title of issue and type of obligation	Amount authorized by indenture	Interest rates	Maturity date	Number of periodic installments	Amount shown under caption "Current portion of long-term debt" in related balance sheet	Amount shown under caption "Long-term debt" in related balance sheet
Loans payable	₱1,628,389	15.16% and 17.00%	October 22, 2013 and July 7, 2016	Payable upon maturity of the loans	₱699,123	₱929,266
Loans payable	12,812,618	8.68% to 10.89%	July 2015	Payable in equal monthly installments starting May 2007 up to July 2015	11,249,891	1,562,727
					₱3,386,256,516	₱31,258,586,349
₱34,644,842,865						

See Note 19 of the Consolidated Financial Statements



Schedule F. Indebtedness to Related Parties (Long-term Loans from Related Companies)

Name of related party	Balance at beginning of period	Balance at end of period
------------------------------	---------------------------------------	---------------------------------

NOT APPLICABLE

Schedule G. Guarantees of Securities of Other Issuers

Name of issuing entity of securities guaranteed by the company for which this statements is filed	Title of issue of each class of securities guaranteed	Total amount guaranteed and outstanding	Amount of owned by person for which statement is filed	Nature of guarantee
--	--	--	---	----------------------------

NOT APPLICABLE



Schedule H. Capital Stock

Title of issue	Number of shares authorized	Number of shares issued and outstanding at shown under related balance sheet caption	Number of shares reserved for options, warrants, conversion and other rights	Number of shares held by		
				Related parties	Directors, officers and employees	Others
Preferred stock - ₱1 par value cumulative and convertible	100,000,000	3,780	–	–	–	3,780
Common stock - ₱1 par value	5,900,000,000	2,655,494,000	–	1,829,073,615	84,751,362	741,669,023
	6,000,000,000	2,655,497,780	–	1,829,073,615	84,751,362	741,672,803

See Note 22 of the Consolidated Financial Statements



DMCI HOLDINGS, INC. AND SUBSIDIARIES

SCHEDULE OF ALL EFFECTIVE STANDARDS AND INTERPRETATIONS UNDER PFRS AS OF DECEMBER 31, 2013

Philippine Securities and Exchange Commission (SEC) issued the amended Securities Regulation Code Rule 68 and 68.1 which consolidates the two separate rules and labeled in the amendment as “Part I” and “Part II”, respectively. It also prescribed the additional schedule requirements for large entities showing a list of all effective standards and interpretations under Philippine Financial Reporting Standards (PFRS).

Below is the list of all effective PFRS, Philippine Accounting Standards (PAS) and Philippine Interpretations of International Financial Reporting Interpretations Committee (IFRIC) as at December 31, 2013:

PHILIPPINE FINANCIAL REPORTING STANDARDS AND INTERPRETATIONS Effective as of December 31, 2013		Adopted	Not Early Adopted	Not Applicable
Framework for the Preparation and Presentation of Financial Statements Conceptual Framework Phase A: Objectives and qualitative characteristics		✓		
PFRSs Practice Statement Management Commentary				✓
Philippine Financial Reporting Standards				
PFRS 1 (Revised)	First-time Adoption of Philippine Financial Reporting Standards			✓
	Amendments to PFRS 1 and PAS 27: Cost of an Investment in a Subsidiary, Jointly Controlled Entity or Associate			✓
	Amendments to PFRS 1: Additional Exemptions for First-time Adopters			✓
	Amendment to PFRS 1: Limited Exemption from Comparative PFRS 7 Disclosures for First-time Adopters			✓
	Amendments to PFRS 1: Severe Hyperinflation and Removal of Fixed Date for First-time Adopters			✓
	Amendments to PFRS 1: Government Loans			✓
PFRS 2	Share-based Payment			✓
	Amendments to PFRS 2: Vesting Conditions and Cancellations			✓
	Amendments to PFRS 2: Group Cash-settled Share-based Payment Transactions			✓
PFRS 3 (Revised)	Business Combinations	✓		
PFRS 4	Insurance Contracts			✓
	Amendments to PAS 39 and PFRS 4: Financial Guarantee Contracts			✓
PFRS 5	Non-current Assets Held for Sale and Discontinued Operations	✓		



PHILIPPINE FINANCIAL REPORTING STANDARDS AND INTERPRETATIONS Effective as of December 31, 2013		Adopted	Not Early Adopted	Not Applicable
PFRS 6	Exploration for and Evaluation of Mineral Resources	✓		
PFRS 7	Financial Instruments: Disclosures	✓		
	Amendments to PAS 39 and PFRS 7: Reclassification of Financial Assets	✓		
	Amendments to PAS 39 and PFRS 7: Reclassification of Financial Assets - Effective Date and Transition	✓		
	Amendments to PFRS 7: Improving Disclosures about Financial Instruments	✓		
	Amendments to PFRS 7: Disclosures - Transfers of Financial Assets	✓		
	Amendments to PFRS 7: Disclosures - Offsetting Financial Assets and Financial Liabilities	✓		
	Amendments to PFRS 7: Mandatory Effective Date of PFRS 9 and Transition Disclosures		✓	
PFRS 8	Operating Segments	✓		
PFRS 9	Financial Instruments		✓	
	Amendments to PFRS 9: Mandatory Effective Date of PFRS 9 and Transition Disclosures		✓	
	New Hedge Accounting Requirements		✓	
PFRS 10	Consolidated Financial Statements	✓		
	Amendments to PFRS 10: Investment Entities		✓	
PFRS 11	Joint Arrangements	✓		
PFRS 12	Disclosure of Interests in Other Entities	✓		
	Amendments to PFRS 12: Investment Entities		✓	
PFRS 13	Fair Value Measurement	✓		
Philippine Accounting Standards				
PAS 1 (Revised)	Presentation of Financial Statements	✓		
	Amendment to PAS 1: Capital Disclosures	✓		
	Amendments to PAS 32 and PAS 1: Puttable Financial Instruments and Obligations Arising on Liquidation			✓
	Amendments to PAS 1: Presentation of Items of Other Comprehensive Income or OCI	✓		
PAS 2	Inventories	✓		
PAS 7	Statement of Cash Flows	✓		
PAS 8	Accounting Policies, Changes in Accounting Estimates and Errors	✓		
PAS 10	Events after the Reporting Date	✓		
PAS 11	Construction Contracts	✓		



PHILIPPINE FINANCIAL REPORTING STANDARDS AND INTERPRETATIONS Effective as of December 31, 2013		Adopted	Not Early Adopted	Not Applicable
PAS 12	Income Taxes	✓		
	Amendment to PAS 12 - Deferred Tax: Recovery of Underlying Assets	✓		
PAS 16	Property, Plant and Equipment	✓		
PAS 17	Leases	✓		
PAS 18	Revenue	✓		
PAS 19 (Revised)	Employee Benefits	✓		
	Amendments to PAS 19: Defined Benefit Plans - Employee Contributions		✓	
PAS 20	Accounting for Government Grants and Disclosure of Government Assistance			✓
PAS 21	The Effects of Changes in Foreign Exchange Rates	✓		
	Amendment: Net Investment in a Foreign Operation			✓
PAS 23 (Revised)	Borrowing Costs	✓		
PAS 24 (Revised)	Related Party Disclosures	✓		
PAS 26	Accounting and Reporting by Retirement Benefit Plans	✓		
PAS 27 (Amended)	Separate Financial Statements	✓		
	Amendments to PAS 27: Investment Entities		✓	
PAS 28 (Amended)	Investments in Associates and Joint Ventures	✓		
PAS 29	Financial Reporting in Hyperinflationary Economies			✓
PAS 32	Financial Instruments: Disclosure and Presentation	✓		
	Amendments to PAS 32 and PAS 1: Puttable Financial Instruments and Obligations Arising on Liquidation			✓
	Amendment to PAS 32: Classification of Rights Issues			✓
	Amendments to PAS 32: Offsetting Financial Assets and Financial Liabilities			✓
PAS 33	Earnings per Share	✓		
PAS 34	Interim Financial Reporting	✓		
PAS 36	Impairment of Assets	✓		
	Amendments to PAS 36: Impairment of Assets - Recoverable Amount Disclosures for Non-Financial Assets	✓		
PAS 37	Provisions, Contingent Liabilities and Contingent Assets	✓		
PAS 38	Intangible Assets	✓		
PAS 39	Financial Instruments: Recognition and Measurement	✓		



PHILIPPINE FINANCIAL REPORTING STANDARDS AND INTERPRETATIONS Effective as of December 31, 2013		Adopted	Not Early Adopted	Not Applicable
	Amendments to PAS 39: Transition and Initial Recognition of Financial Assets and Financial Liabilities	✓		
	Amendments to PAS 39: Cash Flow Hedge Accounting of Forecast Intragroup Transactions			✓
	Amendments to PAS 39: The Fair Value Option			✓
	Amendments to PAS 39 and PFRS 4: Financial Guarantee Contracts			✓
	Amendments to PAS 39 and PFRS 7: Reclassification of Financial Assets	✓		
	Amendments to PAS 39 and PFRS 7: Reclassification of Financial Assets - Effective Date and Transition	✓		
	Amendments to Philippine Interpretation IFRIC 9 and PAS 39: Embedded Derivatives			✓
	Amendment to PAS 39: Eligible Hedged Items			✓
	Amendments to PAS 39: Financial Instruments: Recognition and Measurement - Novation of Derivatives and Continuation of Hedge Accounting			✓
PAS 40	Investment Property	✓		
PAS 41	Agriculture			✓
Philippine Interpretations				
IFRIC 1	Changes in Existing Decommissioning, Restoration and Similar Liabilities	✓		
IFRIC 2	Members' Share in Co-operative Entities and Similar Instruments			✓
IFRIC 4	Determining Whether an Arrangement Contains a Lease	✓		
IFRIC 5	Rights to Interests arising from Decommissioning, Restoration and Environmental Rehabilitation Funds	✓		
IFRIC 6	Liabilities arising from Participating in a Specific Market - Waste Electrical and Electronic Equipment			✓
IFRIC 7	Applying the Restatement Approach under PAS 29 Financial Reporting in Hyperinflationary Economies			✓
IFRIC 8	Scope of PFRS 2			✓
IFRIC 9	Reassessment of Embedded Derivatives	✓		
	Amendments to Philippine Interpretation IFRIC 9 and PAS 39: Embedded Derivatives	✓		
IFRIC 10	Interim Financial Reporting and Impairment	✓		
IFRIC 11	PFRS 2- Group and Treasury Share Transactions			✓
IFRIC 12	Service Concession Arrangements			✓
IFRIC 13	Customer Loyalty Programmes			✓



PHILIPPINE FINANCIAL REPORTING STANDARDS AND INTERPRETATIONS Effective as of December 31, 2013		Adopted	Not Early Adopted	Not Applicable
IFRIC 14	The Limit on a Defined Benefit Asset, Minimum Funding Requirements and their Interaction	✓		
	Amendments to Philippine Interpretations IFRIC- 14, Prepayments of a Minimum Funding Requirement			✓
IFRIC 15	Agreements for the Construction of Real Estate		✓	
IFRIC 16	Hedges of a Net Investment in a Foreign Operation			✓
IFRIC 17	Distributions of Non-cash Assets to Owners			✓
IFRIC 18	Transfers of Assets from Customers			✓
IFRIC 19	Extinguishing Financial Liabilities with Equity Instruments			✓
IFRIC 20	Stripping Costs in the Production Phase of a Surface Mine	✓		
IFRIC 21	Levies		✓	
SIC-10	Government Assistance - No Specific Relation to Operating Activities			✓
SIC-12	Consolidation - Special Purpose Entities			✓
	Amendment to SIC - 12: Scope of SIC 12			✓
SIC-13	Jointly Controlled Entities - Non-Monetary Contributions by Venturers			✓
SIC-15	Operating Leases - Incentives	✓		
SIC-21	Income Taxes - Recovery of Revalued Non-Depreciable Assets			✓
SIC-25	Income Taxes - Changes in the Tax Status of an Entity or its Shareholders			✓
SIC-27	Evaluating the Substance of Transactions Involving the Legal Form of a Lease	✓		
SIC-29	Service Concession Arrangements: Disclosures.			✓
SIC-31	Revenue - Barter Transactions Involving Advertising Services			✓
SIC-32	Intangible Assets - Web Site Costs			✓

Standards tagged as “Not early adopted” are standards issued but not yet effective as of December 31, 2013. The Group will adopt the Standards and Interpretations when these become effective.

Standards tagged as “Not applicable” have been adopted by the Group but have no significant covered transactions for the year ended December 31, 2013.



DMCI HOLDINGS, INC.**SUPPLEMENTARY SCHEDULE OF RETAINED EARNINGS AVAILABLE
FOR DIVIDENDS DECLARATION
FOR THE YEAR ENDED DECEMBER 31, 2013**

Unappropriated Retained Earnings, beginning	₱8,502,353,924
Adjustments	—
Amortization of discount on payable to landowners	48,653
Effect of adoption of the Revised PAS 19	(21,319,084)
Unappropriated Retained Earnings as adjusted, beginning	8,481,083,493
Net income actually earned/realized during the year	
Net income during the year closed to Retained Earnings	16,651,290,588
Less: Non-actual/unrealized income, net of tax	
Equity in net income of associate/joint venture	—
Unrealized foreign exchange gain - net	—
Unrealized actuarial gain	—
Fair value adjustment (M2M gains)	—
Fair value adjustment of Investment Property resulting to gain	—
Adjustment due to deviation from PFRS/GAAP - gain	—
Other unrealized gains or adjustments to the retained earnings as a result of certain transactions accounted for under the PFRS	—
Add: Non-actual losses	
Movements in deferred tax assets	—
Depreciation on revaluation increment (after tax)	—
Adjustment due to deviation from PFRS/GAAP - loss	—
Loss on fair value adjustment of investment property (after tax)	—
	16,651,290,588
Less: Dividend declarations during the year	
Cash dividends	(9,028,679,600)
Appropriation for capital expenditures, investments and future dividend declaration	(1,300,000,000)
Reversal of Appropriation for capital expenditures, investments and future dividend declaration	3,800,000,000
Total Unappropriated Retained Earnings Available For Dividend Distribution, December 31, 2013	₱18,603,694,481



DMCI HOLDINGS, INC. AND SUBSIDIARIES
MAP OF RELATIONSHIPS OF THE COMPANIES WITHIN THE GROUP

Group Structure

Below is a map showing the relationship between and among the Group and its ultimate parent company, subsidiaries, and associates as of December 31, 2013:

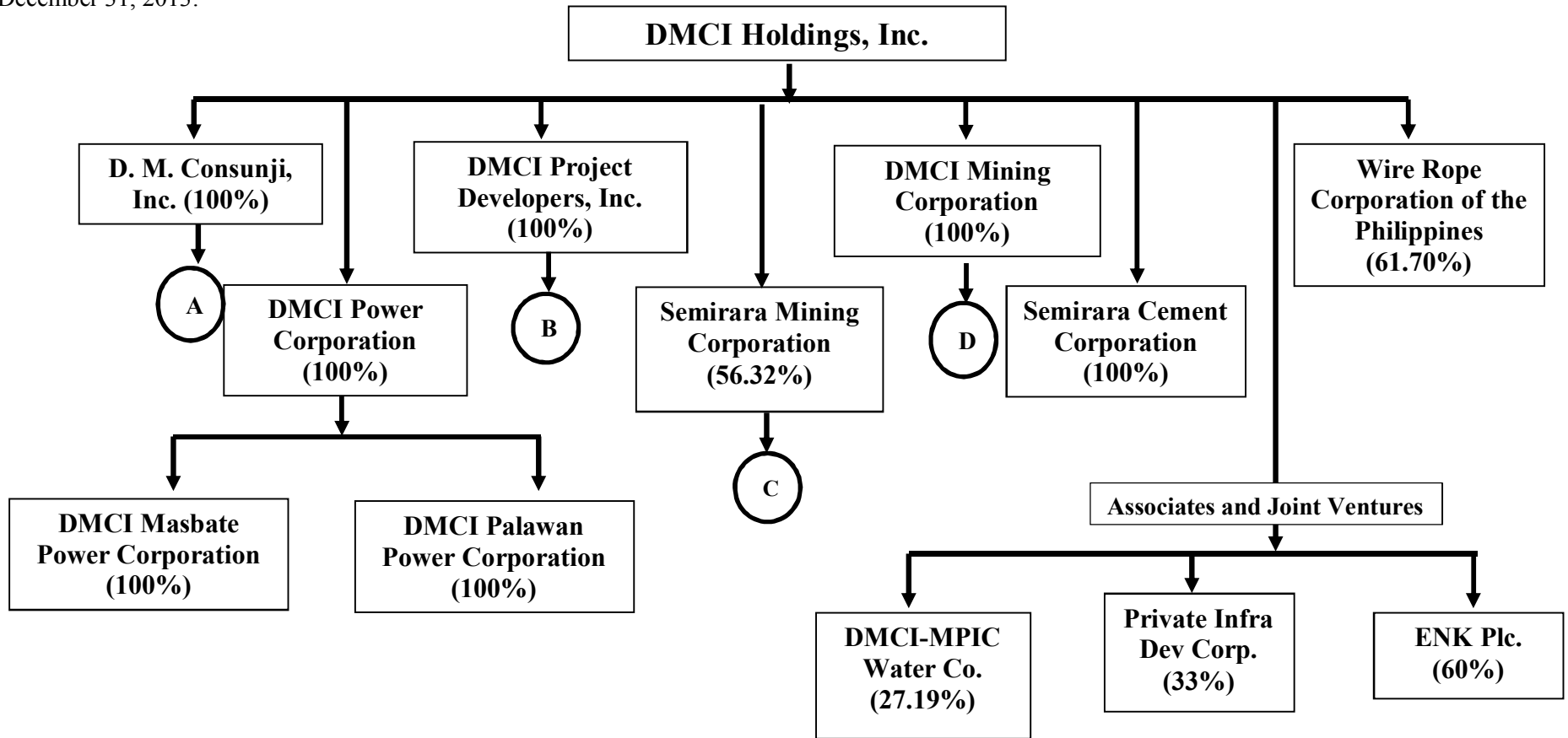

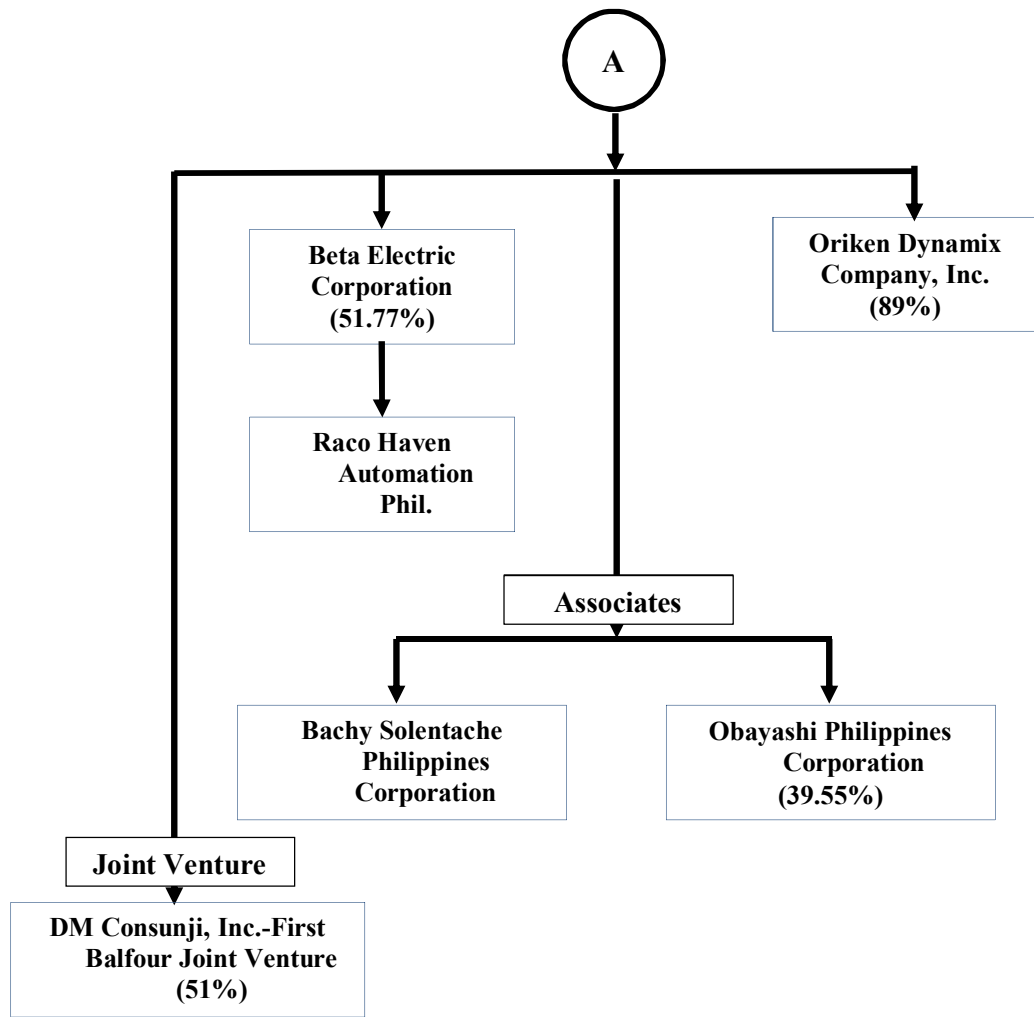

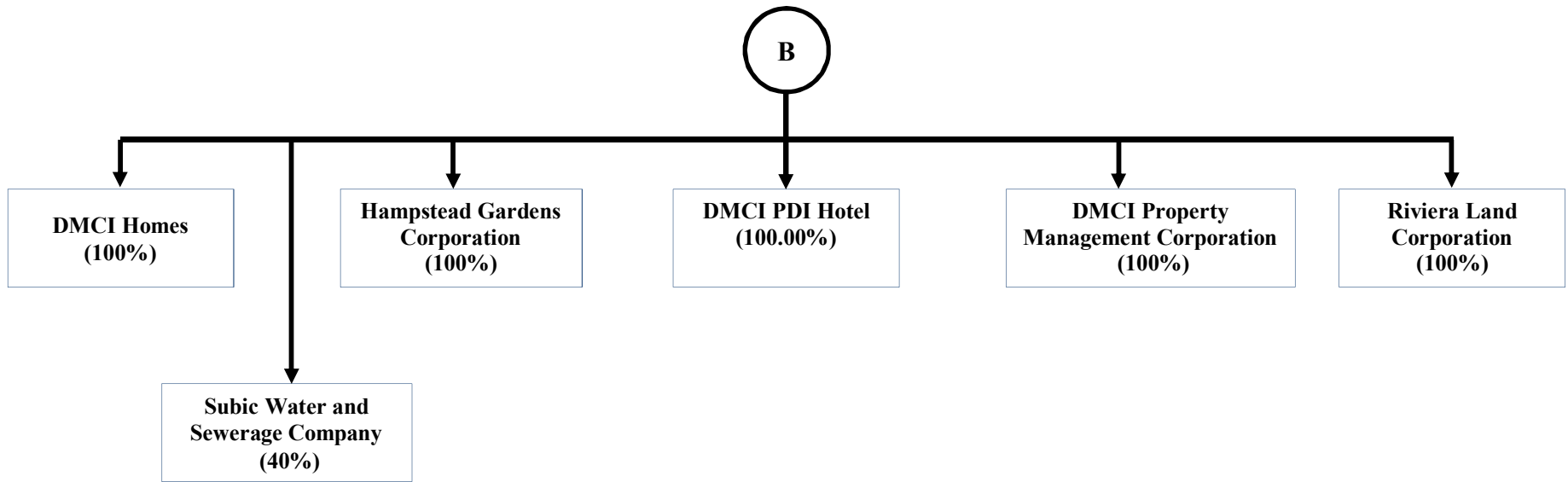

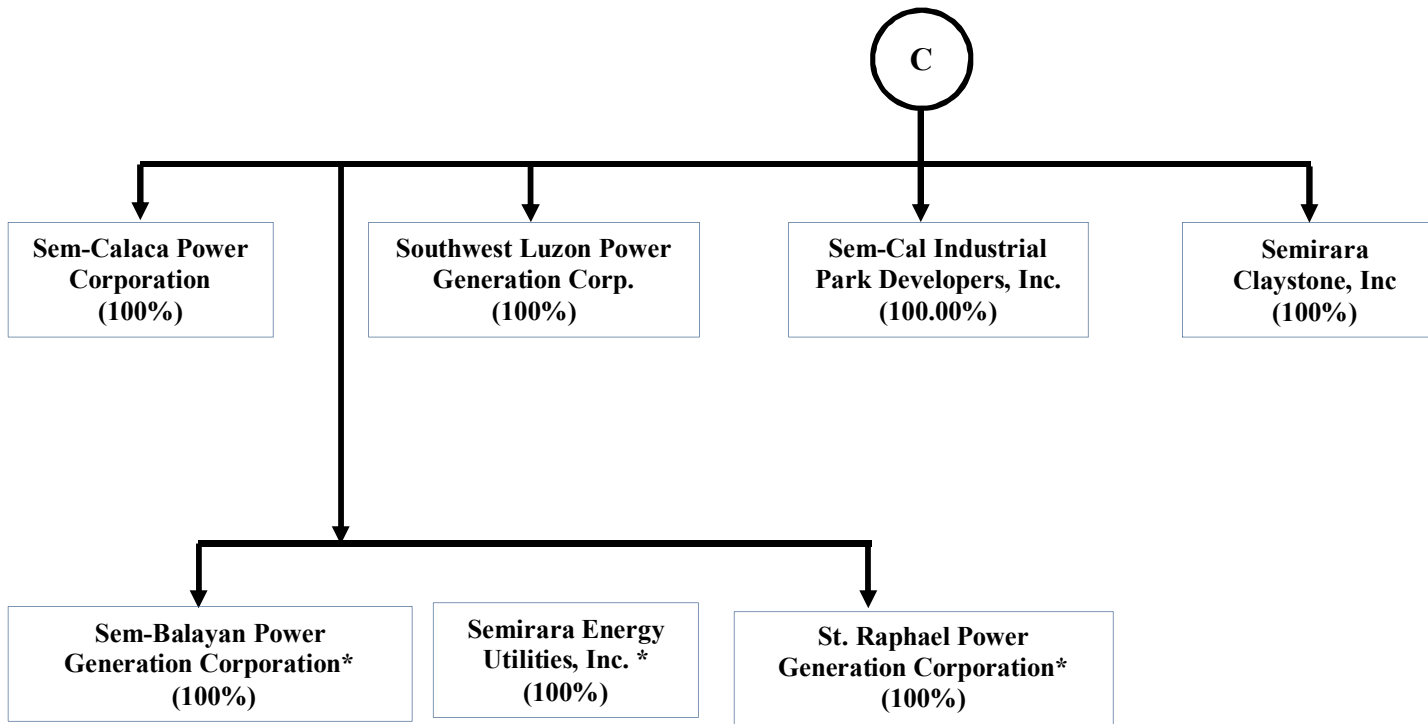

**newly incorporated entities*



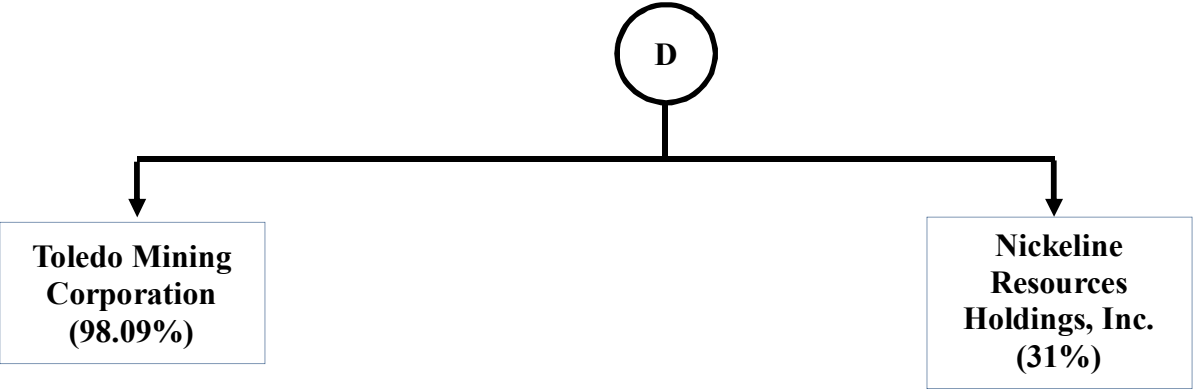

DMCI HOLDINGS, INC. AND SUBSIDIARIES
SCHEDULE OF FINANCIAL SOUNDNESS INDICATORS
FOR THE YEAR ENDED DECEMBER 31, 2013 and 2012

Financial Soundness Indicator	2013	2012
i. Liquidity ratios:		
Current ratio	246.61%	180.02%
Quick ratio	166.34%	101.34%
ii. Leverage ratios:		
Debt-to-equity ratio	61.07%	52.23%
Interest coverage ratio	2621.40%	1165.33%
iii. Management ratios:		
Inventory turnover ratio	153.18%	177.34%
Accounts receivable turnover ratio	424.08%	522.09%
Return on assets ratio	20.17%	13.76%
Return on equity ratio	40.85%	27.81%
iv. Asset-to-equity ratio	205.56%	198.92%
v. Profitability ratios:		
Gross margin ratio	38.85%	33.16%
Net profit margin ratio	39.77%	24.14%

**See attached reporting computation.*



DMCI HOLDINGS, INC. AND SUBSIDIARIES
SCHEDULE OF FINANCIAL SOUNDNESS INDICATORS
FOR THE YEAR ENDED DECEMBER 31, 2013 and 2012

	2013	2012
	(Amounts in thousands)	
Current assets	₱71,185,790	₱49,225,654
Current liabilities	28,865,344	27,344,422
Current ratio	246.61%	180.02%
Current assets	₱71,185,790	₱49,225,654
Inventories	23,171,833	21,515,161
Quick assets	48,013,957	27,710,493
Current liabilities	28,865,344	27,344,422
Quick ratio	166.34%	101.34%
Interest-bearing loans	₱36,764,139	₱25,466,086
Equity	60,203,077	48,756,092
Debt-to-equity ratio	61.07%	52.23%
Earnings before income tax	₱24,361,409	₱13,966,809
Interest expense	929,328	1,198,528
Interest coverage ratio	2621.40%	1165.33%
Cost of goods sold	₱34,224,968	₱34,580,636
Average inventory	22,343,497	19,499,918
Inventory turnover ratio	153.18%	177.34%
Net credit sales	₱55,970,630	₱51,739,879
Average accounts receivable	13,198,212	9,910,055
Accounts receivable turnover ratio	424.08%	522.09%
Net income	₱22,256,759	₱12,492,255
Average total assets	110,367,423	90,806,704
Return on assets ratio	20.17%	13.76%
Net income	₱22,256,759	₱12,492,255
Average total equity	54,479,585	44,912,379
Return on equity ratio	40.85%	27.81%
Total assets	₱123,750,759	₱96,984,086
Total equity	60,203,077	48,756,092
Asset-to-equity ratio	205.56%	198.92%
Gross profit	₱21,745,662	₱17,159,243
Sales	55,970,630	51,739,879
Gross profit margin	38.85%	33.16%
Net income	₱22,256,759	₱12,492,255
Sales	55,970,630	51,739,879
Net profit margin	39.77%	24.14%

